

INTERSECTIONS WITHOUT STOP SIGNS OR STOP LIGHTS

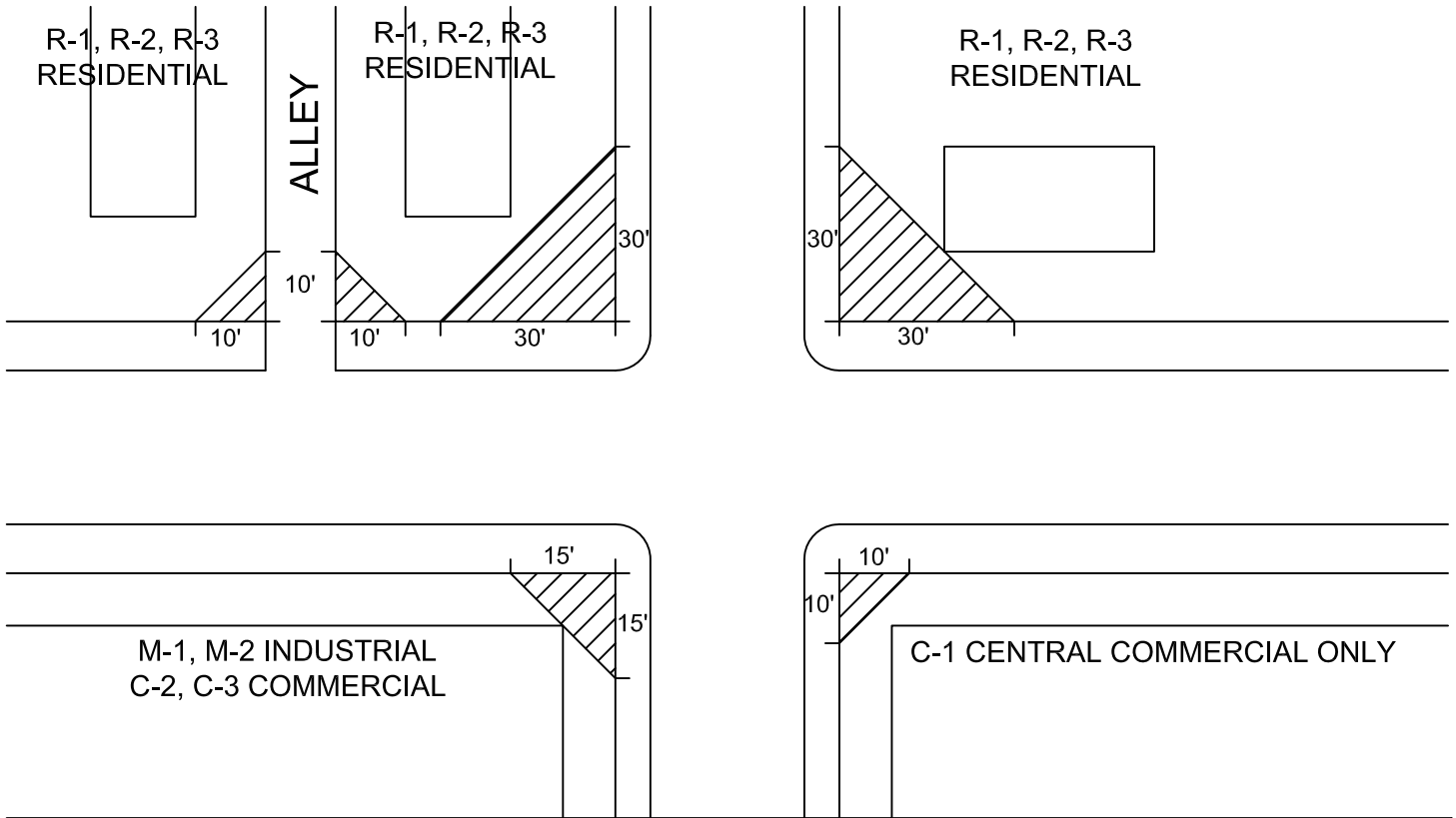

INTERSECTIONS WITH STOP SIGNS OR STOP LIGHTS

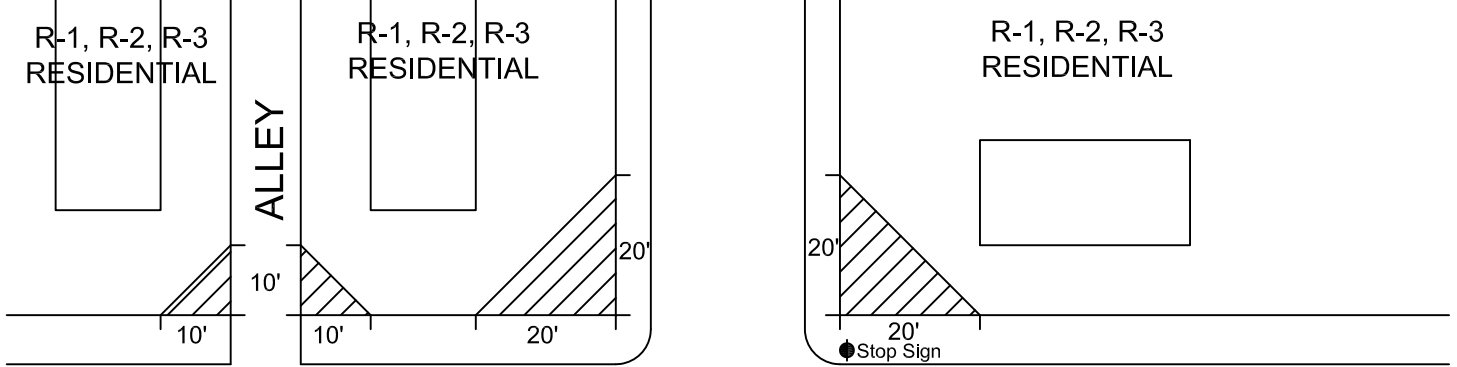

● Traffic Light

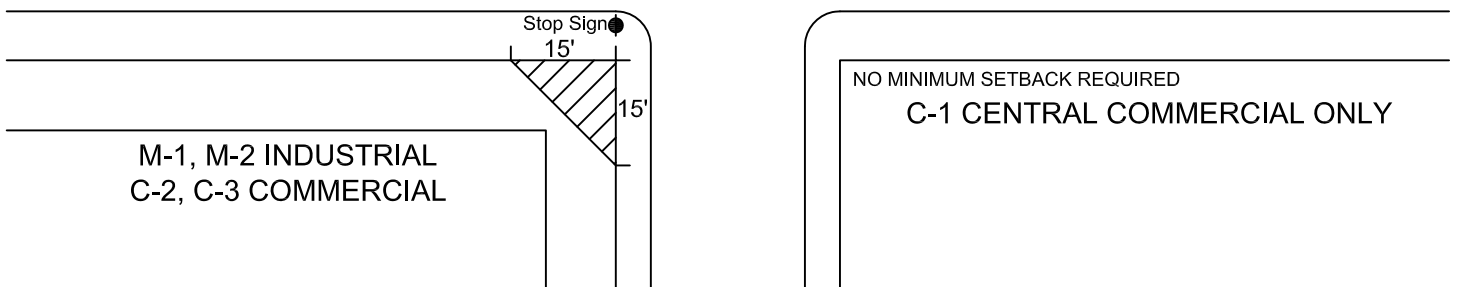

EXHIBIT "C"

CLEAR-VISION AREAS

CLEAR-VISION AREAS CANNOT HAVE A PLANT, FENCE, WALL, STRUCTURE, OR TEMPORARY OR PERMANENT OBSTRUCTION HIGHER THAN 2-1/2 FEET. TREES TALLER THAN 2-1/2 FEET ARE ALLOWED IN CLEAR-VISION AREAS IF THEY ARE TRIMMED IN ACCORDANCE WITH EXHIBIT "B."