

CITY OF PENDLETON

2022 URD Project - SE 3rd Street Water Line



Expires: 6/30/24

Stamped: 9/19/22

October 2022

Public Works Department
500 SW Dorion Avenue
Pendleton, OR 97801

www.pendleton.or.us

Office (541) 966-0202

Fax (541) 966-0251

TABLE OF CONTENTS

INVITATION TO BID..... 1.00

INFORMATION FOR BIDDERS

PREQUALIFICATION 2.00

BID PROPOSAL 3.00

BID BOND 4.00

STATUTORY PUBLIC WORKS BOND..... 5.00

CONTRACT 6.00

ASSIGNMENT OF ANTITRUST RIGHTS..... 7.00

NON-COLLUSION AFFIDAVIT 8.00

PERFORMANCE/PAYMENT BOND..... 9.00

CERTIFICATE OF INSURANCE 10.00

SPECIAL CONDITIONS 11.00

IRS FORM W-9 (Taxpayer ID number and certification)..... 12.00

SPECIAL SPECIFICATIONS..... 13.00

DRAWINGS..... 14.00

INVITATION TO BID

Sealed bids for the **2022 URD Project - SE 3rd Street Water Line** will be received by the City of Pendleton, c/o Bob Patterson, Public Works Director, 500 SW Dorion Avenue, Pendleton, OR 97801 until **2:00 pm local time on the 11th day of October, 2022**, plainly marked **"2022 URD Project - SE 3rd Street Water Line"**.

Bid opening will be available via Zoom or at the Public Works Director's office conference room located at that same address as above at 2:00 pm local time October 11, 2022. **Contact the Public Works Director's office at 541 966-0202 or Jutta Haliewicz at 541 966-0240, jutta.haliewicz@ci.pendleton.or.us for the Zoom link.**

A copy of the bid documents may be obtained for a **non-refundable fee of \$25.00** from the Public Works Director's office located at the same address as above or by calling (541) 966-0202. A copy is also available online at the **OregonBuys website: <https://oregonbuys.gov/bsu/view/login/login.xhtml>** or on the **City of Pendleton's website: www.pendleton.or.us/rfps**. For the nearest location of a review copy, contact the Public Works Director's office. **Bid documents will be available until 5:00 pm, Friday, October 7, 2022.** The Oregon Standard Specifications for Construction (ODOT/APWA) latest revision, excluding Sections 00100 and 00745.95, and the City of Pendleton Standard Specifications will apply to all construction work not noted in the Special Specifications. It is the Contractor's responsibility to obtain the latest revisions made to these specifications (latest revisions to City Standard Specifications, January 2001 with minor revisions 2001, 2004, 2005, 2006 and 2012).

All bidders must be prequalified for the class of work included in this bid document in accordance with the laws of the State of Oregon, and all prequalification applications must be submitted to the City by 1:00 pm, October 10, 2022, the day before the bid opening. (See Section 2.00)

The City of Pendleton will not mail notice of Addenda, but will post notice of any Addenda on the OregonBuys website and the City's website (www.pendleton.or.us/rfps). Addenda may be downloaded off these websites and will be faxed or emailed to all bidders who have requested to be on the City's Planholders List. Contact jutta.haliewicz@ci.pendleton.or.us to be added to the list. Bidders should frequently check the websites until bid closing.

Each Bid Proposal must be submitted on the prescribed form (Section 3.00) accompanied by a certified or cashier's check drawn from an Oregon Bank in good standing, or banks doing business in Oregon in good standing, or a Bid Bond issued by a surety company authorized to issue such bonds in the State of Oregon, payable to the City of Pendleton, Oregon, in an amount not less than five percent (5%) of the total amount of the Bid submitted.

All bidders must comply with ORS Chapter 279C and pay applicable prevailing wage rates in effect on July 1, 2022, including any amendments, as stated in the [Prevailing Wage Rates for Public Works Contracts in Oregon](#) published by the Oregon Bureau of Labor and Industries (see www.oregon.gov/boli).

The successful bidder will be required to furnish a bond for faithful performance of the contract in the full amount of the contract price. In addition to required performance bonds which may be used for unpaid wages, all contractors, subcontractors and non-construction companies working on public works projects, with a contract price that exceeds \$100,000, subject to the Prevailing Wage Rate law, must file a \$30,000 Public Works Bond with the Construction Contractor's Board before starting work on the project, unless exempt, to be used exclusively for unpaid wages determined to be due by BOLI .{ORS 279C.830 and ORS 279C.836} **(See forms included in Section 5.00)**

Each bidder must identify whether they are a resident bidder as defined in ORS 279A.120. (Preference for Oregon goods and services)

Nonresident Bidders: ORS 279A.120(3) states: "When a public contract is awarded to a nonresident bidder and the contract price exceeds \$10,000, the bidder shall promptly report to the Department of Revenue (DOR) on forms to be provided by the department the total contract price, terms of payment, length of contract and such other information as the department may require before the bidder may receive final payment on the public contract. The contracting agency shall satisfy itself that the requirement of this subsection has been

complied with before the contracting agency issues a final payment on a public contract.” See form attached to the end of Special Conditions (Section 11.00). For information about DOR requirements, contact: <http://www.oregon.gov/DOR>

The Contractor shall, within two (2) working hours of the advertised bid opening, submit the first-tier subcontractor disclosure form. This form is to notify the Public Works Director in writing the names of the first-tier subcontractors. The disclosure form is attached to the end of the Special Conditions (Section 11.00). If no subcontractors need to be disclosed, enter “NONE” on the form and submit it.

The Contractor, its subcontractors, if any, and all employers working under this Contract are subject employers under the Oregon Workers’ Compensation law and shall comply with ORS Chapter 656, which requires them to provide workers’ compensation coverage for all their subject workers.

The City reserves the right to accept that proposal which is in the best interest of the City of Pendleton, Oregon and to postpone the award of the Contract for a period not to exceed thirty (30) calendar days.

The deadline for filing a protest by the second responsible bidder is seven (7) calendar days after the Notice of Intent to Award has been issued. Protest must be in written form and received by 5:00 pm on the 7th day from the date of the letter of intent to award issued by the Public Works Director or his designated representative. Once the Notice of Intent to Award has been issued, bid submittal information will be available for public review.

Dated this 19th day of September, 2022.

Bob Patterson

Bob Patterson (Sep 19, 2022 12:19 PDT)

Bob Patterson, Public Works Director

INFORMATION FOR BIDDERS

City of Pendleton, hereby referred to as OWNER, will be completing work under one contract for **2022 URD Project - SE 3rd Street Water Line**. Bids are expected to be opened **2:00 pm, local time, October 11, 2022**. Bid award, with seven (7) calendar day notice of intent declaration, will likely take place on Tuesday, October 18, 2022, at the regularly scheduled City Council meeting.

The work to be performed under these contract documents consists of furnishing all labor, materials and equipment necessary for the construction of the following:

Installation of 740 linear feet (LF) of 18-inch water main and 640 LF of 12-inch water main on SE 3rd Street from the cul-de-sac north of SE Byers Avenue to SE Frazer Avenue. The new 12-inch water main will connect to two existing 12-inch water mains in the cul-de-sac and extend to SE Byers Avenue and make a connection with a 12-inch water main the City has already installed. New 12-inch water main will be installed between SE Byers Avenue and SE Court Avenue with 12- and 18-inch connections to existing. New 18-inch water main will be installed between SE Court Avenue and SE Dorion Avenue and between SE Dorion Avenue and SE Emigrant Avenue with 18-inch connections to existing. A new fire hydrant will be installed at the cul-de-sac and a fire hydrant will be replaced at the SE corner of SE Court Avenue. The Contractor shall have the option of installing PVC or ductile iron water line of the type and class specified in the Bid Proposal.

The City will tap the water main for the water services; however, the Contractor will be required to dig and backfill trenches and must coordinate with City crews to install the service. The Contractor will be required to make connections and install the 6-inch fire service lines. The City will provide specific fittings for this project. Fittings supplied by the City are identified on the Bid Proposal. The Contractor shall be required to provide all other materials including the MegaLug restraints required for the MJ fittings the City provides.

Contractor to note the crossing over the sewer main shall conform to OAR 333-061-0050(9).

The above information is a general outline of principal features of the work. It does not in any way limit the responsibility of the CONTRACTOR(s) to perform all work and furnish all equipment, labor and materials required by the specifications and drawings. The drawings and specifications shall be considered and used together. Anything appearing as a requirement of either shall be accepted as applicable to both even though not so stated therein or shown.

No attempt has been made in the specifications or drawings to segregate work covered by any trade or subcontract under one specification. Such segregation and establishment of subcontract limits will be solely a matter of specific agreement between the CONTRACTOR and its subcontractors and shall not be based upon any inclusion, segregation or arrangement in or of these specifications.

Bidders must submit the following completed documents with their bids by the bid due date (Tuesday, October 11, 2022) and time (2:00 pm) indicated on the Invitation to Bid (Section 1.00) or as stated on any addendum(s) stating otherwise. **Bids not containing the following items may be considered non-responsive:**

- **Bid Proposal – form signed by company representative having authority to submit bids – see Section 3.00**
- **Copies of all material quote(s), if Bidder wants materials excavator exercised via change order.**
- **Bid Bond/Security (5%) in form of certified or cashier's check drawn from an Oregon Bank – see Section 4.00**
- **Acknowledgement of ALL Addenda**
- **Non-Collusion Affidavit (signed by company representative and notarized) – see Section 8.00**

Document to be submitted by Disclosure Deadline Date and Time:

- **First-Tier Subcontractor Disclosure Form - end of Section 11.00 (Special Conditions)**

Upon award of contract the SUCCESSFUL BIDDER must be prepared to submit the following completed documents within ten (10) calendar days of contract award:

Contract Forms and Submittals:

- Three original signed contracts (to be provided by City)
- Updated material quotes. If the updated material quotes demonstrate an increase in cost of 1.0% or more for the material price, the Proposal unit pricing will be increased by the difference and be acknowledged through Change Order for the overall project.
- Copy of Statutory Public Works Bond
- Performance and Payment Bond
- Certificate of Liability Insurance
- Oregon Nonresident Bidder Form (if applicable)
- IRS Form W-9
- Application and payment for City Business License (Contractor and any subcontractors)
- Signed copy of Special Conditions (Section 11.00)
- BOLI Wage Rate Worksheet (indicating BOLI Wage Rates used for the project)
 - Example worksheet attached
- Construction Schedule

BOLI WAGE RATE WORKSHEET

| CLASSIFICATION | BOLI REGION RATE | | | BOLI APPENDIX RATE | | |
|----------------|------------------|------------------|--------|------------------------|------------------|--------|
| | BASIC HOURLY | HOURLY FRINGE | TOTAL | BASIC HOURLY W/ZONE | HOURLY FRINGE | TOTAL |
| | | | \$0.00 | | | \$0.00 |
| | | | \$0.00 | | | \$0.00 |
| | | | \$0.00 | | | \$0.00 |
| | | | \$0.00 | | | \$0.00 |
| | | | \$0.00 | | | \$0.00 |
| | | | \$0.00 | | | \$0.00 |
| | | | \$0.00 | | | \$0.00 |
| | | | \$0.00 | | | \$0.00 |
| | | | \$0.00 | | | \$0.00 |
| | | | \$0.00 | | | \$0.00 |
| | | | \$0.00 | | | \$0.00 |
| | | | \$0.00 | | | \$0.00 |
| | | | \$0.00 | | | \$0.00 |
| | | | \$0.00 | | | \$0.00 |
| | | | \$0.00 | | | \$0.00 |
| | | | \$0.00 | | | \$0.00 |
| | | | \$0.00 | | | \$0.00 |
| | | | \$0.00 | | | \$0.00 |
| | | | \$0.00 | | | \$0.00 |
| | | | \$0.00 | | | \$0.00 |
| | | | \$0.00 | | | \$0.00 |
| | | | \$0.00 | | | \$0.00 |
| | | | \$0.00 | | | \$0.00 |
| | | | \$0.00 | | | \$0.00 |
| | | | \$0.00 | | | \$0.00 |
| | | | \$0.00 | | | \$0.00 |

PREQUALIFICATION

PUBLIC WORKS DEPARTMENT
CITY OF PENDLETON
PENDLETON, OREGON

Oregon Law requires a statement as to financial ability, equipment and experience to be completed and submitted by prospective contractors bidding on contracts for public improvements, the estimated cost of which is \$10,000 or over. No contractor is eligible to bid until this statement has been submitted.

Bidders must be prequalified for the class of work included in the bid documents. The City of Pendleton no longer accepts a copy of a bidder's approved Oregon Department of Transportation's prequalification application or approval letter. The City requires their own application to be completed and filed with the City Engineering Department. All prequalification applications must be submitted to the City by **1:00 pm the day before the bid opening.**

Upon request, this application is available to you through this office at 541 966-0203 or online at <https://pendleton.or.us/cdev/page/prequalification-application-2022> for your use in prequalification for this work.

PROPOSAL

Honorable Mayor and City Council
City Hall
Pendleton, Oregon 97801

The undersigned, hereinafter called the Bidder, declares that the only persons or parties interested in this Proposal are those named herein, that the Proposal is in all respects fair and without fraud, but it is made without collusion with any official or employee of the City of Pendleton, Oregon, and that the Proposal is made without any connection or collusion with any person making another Proposal on this Contract.

The Bidder further declares that he has carefully examined the Contract Documents for the construction of the proposed improvements, and he has personally inspected the site, and he has satisfied himself as to the quantities of the materials, items of equipment, and conditions of work involved, including the fact that the description of the work and materials, as included herein, is brief and is intended only to indicate the general nature of such items and to identify the said quantities with the detailed requirements of the Contract Documents, and that this Proposal is made according to the provisions and under the terms of the Contract Documents, which Documents are hereto attached and are hereby made a part of this Proposal.

The Bidder agrees that the Proposal pricing listed is FIRM at the time bids are opened prior to bid award. City will accept modification to the Proposal unit pricing after award, if all material quotes at the time of bid are provided with the Proposal. After the contract is executed by Successful Bidder and City, updated material quotes must be provided within ten (10) calendar days. If the updated material quotes demonstrate an increase in cost of 1.0% or more for the material price, the Proposal unit pricing will be increased by the difference and be acknowledged through Change Order for the overall project.

The Bidder agrees that if this Proposal is accepted, Bidder will, within ten (10) calendar days after notification of acceptance, execute the Contract with the City of Pendleton, Oregon, in the form of Contract annexed thereto, and will, at the time of execution of the Contract, deliver to the City of Pendleton, the Performance Bond required herein, and will to the extent of his Proposal, furnish all machinery, tools, and apparatus and other means of construction and do all the work and furnish all the materials necessary to complete the work in the manner and in the time and according to the methods as specified in the Contract Documents and required by the Engineer there under.

The Bidder agrees to complete the work identified for each schedule of work at the option of the City of Pendleton. The City, at its sole discretion, will identify and select the schedules of work that best fit the City's budget for this work.

In the event the Bidder is awarded the Contract and shall fail to complete the work within the time limit or extended time limit agreed upon, as more particularly set forth in the Contract Documents, liquidated damages shall be paid the City of Pendleton, Oregon, at the rate of one percent (1%) per calendar day of the price of contract work not yet completed, or \$500.00 per calendar day, whichever is greater, for work not completed **by June 30, 2023**. Sundays and legal holidays shall be excluded in determining days of default.

Contractor to note that if the water line is not installed before the local asphalt plants are closed for the season, then the Contractor shall temporarily patch with cold mix or Control Density Fill (CDF) at no additional cost to the Contract. The Contractor will be required to maintain the temporary patch until a final patch with hot mix asphalt can be installed. The final patch shall be installed by June 30, 2023, in order to avoid assessment of liquidated damages.

Contractor to note that if there are delays with water parts delivery that would cause the Contractor to miss the Contract Deadline, then the Contractor will need to provide proof from their Supplier regarding the delayed delivery, and the City will consider giving a contract timeline extension. If a contract timeline extension is granted, then the Contractor must complete the Project no later than forty-five (45) days after the final delivery of the parts.

The Bidder further proposes to accept as full payment for the work proposed herein the amount computed under the provisions of the Contract Documents and based on the following unit price amounts, it being expressly understood that the unit prices are independent of the exact quantities involved, that they represent a true measure of the labor and material required to perform the work, including all allowances for overhead and profit for each type and unit of work called for in these Contract Documents.

The Contract will be awarded based on bids. City reserves the right to award or reject the bids that are in the best interest of the City.

Bidders must submit the following completed documents with their bids by the bid due date **(October 11, 2022)** and time **(2:00 pm)** indicated on the Invitation to Bid (Section 1.00) or as stated on any addendum(s) stating otherwise. **Bids not containing the following items may be considered non-responsive:**

- **Bid Proposal form (dated and signed by company representative having authority to submit bids) – Section 3.00**
- **Copies of all material quote(s) if Bidder wants materials escalator exercised via change order.**
- **Bid Bond/Security (5%) in form of certified or cashier's check drawn from an Oregon Bank – see Section 4.00**
- **Acknowledgement of ALL Addenda**
- **Non-Collusion Affidavit (signed by company representative and notarized) - see Section 8.00**

Document to be submitted by Disclosure Deadline Date and Time:

- **First-Tier Subcontractor Disclosure Form – see end of Section 11.00**

The following instructions outline the procedure for preparing and submitting Bids. Bidders must fulfill all requirements as specified in this Contract Document:

- Prequalification must be submitted by 1:00 pm the day before the bid opening date (**bid opening date: October 11, 2022**).
- Bidders shall use only the Bid Proposal form provided in this Contract Document. A bid amount shall be submitted in the appropriate place for each Item for which a Bid is being submitted. All blank spaces in the Bid Proposal form must be filled in completely where required. No changes shall be made in the phraseology of the forms.
- Bid will be awarded based on grand total bid amount.
- The Bid Proposal form may be submitted separately from the remainder of these Contract Documents. It must be submitted in a sealed envelope and marked clearly to indicate its contents without being opened.
- **The Bidder shall acknowledge receipt of all Addenda to the Bid. Bids received without acknowledgement or without the Addenda enclosed may be considered nonconforming. Notice of Addenda will not be mailed but will be posted on City's website (www.pendleton.or.us/rfps) and the OregonBuys website (<https://oregonbuys.gov/bs0/view/login/login.xhtml>). Addenda may be downloaded off website and will be faxed or emailed to all bidders who have notified City to request their firm be placed on the Planholders list. Bidders should frequently check the websites until bid closing.**
- Any taxes required by the laws and statutes of the State of Oregon and its political subdivisions shall be paid by the Contractor.
- Owner will pay all permit expenses with the exception of temporary permits related to construction work. The successful Bidder must pay all temporary permit expenses.
- All Bids must be submitted no later than the prescribed time, place, and manner set forth in the Contract Documents.
- Bids without sufficient data to provide a complete evaluation may not be considered.
- Any Bidder may modify its Bid by telegraphic or written communication at any time prior to the scheduled closing time for receipt of the Bids, provided the Owner receives such communication prior to the closing time. The telegraphic or written communication should not reveal the Bid Amount; however, it should state the addition, subtraction, or other modification so that the final amount or terms will not be known to the Owner until the sealed Bid is opened.
- Bids cannot be modified at any time following the deadline for receipt of the Bids.
- **Bids must be accompanied by a certified or cashier's check drawn from an Oregon Bank in good standing, or banks doing business in Oregon in good standing, or a Bid Bond issued by a surety company authorized to issue such bonds in the State of Oregon, in an amount not less than five percent (5%) of the total amount of the Bid submitted.** This check or Bid Bond shall be given as guarantee that if awarded the Contract, the successful Bidder will execute the Contract within the time specified. See Standard Specifications for the City of Pendleton – Section 1:06 – Bid Security for more information. (See Section 4.00)
- **Non-Collusion Affidavit must be submitted with the Bid; otherwise, the Bid may be considered non-responsive. (See Section 8.00)**
- **First-Tier Subcontractor Disclosure Form must be submitted by the date and time designated in the Invitation to Bid. This Form must be submitted separately for each Schedule, even if there are no subcontractors that need to be disclosed; otherwise, the Bid will be considered non-responsive. See Special Conditions (Section 11.00) for more information and a copy of the Disclosure Form.**

The Owner will make the award of work based on the best interests of the City of Pendleton. The Owner also reserves the right to reject any or all bids and to postpone the award of the work for a period not to exceed thirty (30) calendar days with time extensions for completion date. The Owner, at its sole discretion, reserves the right to select the bid(s) most beneficial to the City of Pendleton.

2022 URD PROJECT - SE 3RD STREET WATER LINE

Time of Completion: **No later than June 30, 2023**

| <u>Item No.</u> | <u>Approx. Quantity</u> | <u>Item with Unit Price Bid</u> | <u>Unit Price</u> | <u>Extended Total</u> |
|-----------------|-------------------------|--|-------------------|-----------------------|
| 1. | LS | Mobilization | _____ | _____ |
| 2. | LS | Traffic control | _____ | _____ |
| 3. | 1,150 SY | Asphalt patching (2-in. asphalt; 4-in. base rock) | _____ | _____ |
| 4. | 50 SY | Asphalt patching (5-in. asphalt; 12-in. base rock) | _____ | _____ |
| 5. | 80 LF | Removal and replacement concrete curb and gutter | _____ | _____ |
| 6. | 90 SY | Removal and replacement concrete sidewalk | _____ | _____ |
| 7. | 150 LF | Removal of curb and gutter; replacement with asphalt curb | _____ | _____ |
| 8. | 80 SY | Removal of sidewalk and replacement with asphalt patch | _____ | _____ |
| 9. | 150 SY | Restorative landscaping (top soil and grass seed) | _____ | _____ |
| 10. | 80 LF | 6-in. C-900 or Class 52 DI Water Main, installed **CIRCLE PIPE TYPE OF CHOICE** | _____ | _____ |
| 11. | 20 LF | 8-in. C-900 or Class 52 DI water main, installed **CIRCLE PIPE TYPE OF CHOICE** | _____ | _____ |
| 12. | 680 LF | 12-in. C-905 or Class 52 DI water main, installed **CIRCLE PIPE TYPE OF CHOICE** | _____ | _____ |
| 13. | 740 LF | 18-in. C-905 or Class 50 DI water main, installed **CIRCLE PIPE TYPE OF CHOICE** | _____ | _____ |

| Item No. | Approx. Quantity | Item with Unit Price Bid | Unit Price | Extended Total |
|-----------------|-------------------------|---------------------------------|-------------------|-----------------------|
| 14. | 4 EA | 6-in. FLG x MJ gate valve | _____ | _____ |
| 15. | 2 EA | 8-in. FLG gate valve | _____ | _____ |
| 16. | 2 EA | *12-in. FLG x MJ gate valve | _____ | _____ |
| 17. | 1 EA | *18-in. FLG x MJ gate valve | _____ | _____ |
| 18. | 4 EA | 6-in. coupling | _____ | _____ |
| 19. | 2 EA | *12-in. coupling | _____ | _____ |
| 20. | 2 EA | *12-in. MJ sleeve | _____ | _____ |
| 21. | 7 EA | *18-in. MJ sleeve | _____ | _____ |
| 22. | 2 EA | *12-in. x 6-in. MJ x FLG tee | _____ | _____ |
| 23. | 1 EA | *12-in. FLG tee | _____ | _____ |
| 24. | 2 EA | *18-in. x 6-in. MJ x FLG tee | _____ | _____ |
| 25. | 1 EA | *18-in. x 8-in. FLG cross | _____ | _____ |
| 26. | 1 EA | *12-in. FLG x MJ adapter | _____ | _____ |
| 27. | 1 EA | *18-in. FLG x MJ adapter | _____ | _____ |
| 28. | 12 EA | 6-in. MJ 45 degree bend | _____ | _____ |
| 29. | 3 EA | *12-in. MJ 45 degree bend | _____ | _____ |
| 30. | 1 EA | *12-in. FLG x MJ 45 degree bend | _____ | _____ |
| 31. | 8 EA | *18-in. MJ 45 degree bend | _____ | _____ |

| Item No. | Approx. Quantity | Item with Unit Price Bid | Unit Price | Extended Total |
|-----------------|-------------------------|---|-------------------|-----------------------|
| 32. | 2 EA | 8-in. x 6-in. FLG x MJ reducer | _____ | _____ |
| 33. | 1 EA | *18-in. x 12-in. MJ x FLG reducer | _____ | _____ |
| 34. | 2 EA | Install standard fire hydrant assembly | _____ | _____ |
| 35. | 4 EA | Connect to existing water main, 6-in. | _____ | _____ |
| 36. | 4 EA | Connect to existing water main, 12-in. | _____ | _____ |
| 37. | 7 EA | Connect to existing water main, 18-in | _____ | _____ |
| 38. | 500 LF | Water service trench | _____ | _____ |
| 39. | 10 EA | Disconnect, plug and abandon water main | _____ | _____ |
| 40. | 1 EA | Remove standard fire hydrant assembly | _____ | _____ |
| 41. | 4 EA | Remove water valve box | _____ | _____ |

****Items with an asterisk shall be supplied by the Owner and installed by the Contractor. The Contractor shall provide all necessary MegaLugs for the MJ fittings supplied by the Owner.***

TOTAL BID AMOUNT: _____

It is agreed that if the Bidder is awarded the Contract for the work proposed herein, and shall fail or refuse to execute the Contract and furnish the specified Performance and Payment Bond within ten (10) days after the receipt of the Notification of Acceptance of his Bid Proposal, then, in that case, the bid security deposited herewith by the said Bidder, according to the conditions of the Request for Proposals and the Information for Bidders, shall be retained by the City of Pendleton, Oregon, in accordance with the terms of the Bond as specified in the Information for Bidders.

The Bidder has examined and carefully studied the Contract Documents, the other related data identified in the Contract Documents, and the following Addenda, receipt of all which is hereby acknowledged:

Addendum Number:

Addendum Date:

The name of the Bidder who is submitting this Proposal is _____

doing business at _____

(Street)

(City)

(State)

(Zip)

which is the address to which all communication concerned with this Proposal and with the Contract shall be sent.

The name of the principal officers of the corporation submitting this Proposal, of the partnership, or of all persons interested in this Proposal as principals are as follows:

Print Name

Print Name

Signature

Signature

Dated this _____ day of _____, 2022.

Signature of Bidder

Title

BID BOND

KNOW ALL MEN BY THESE PRESENTS, that we, the undersigned, _____
 _____ as Surety, are hereby held and firmly bound unto _____
 _____ as OWNER in the penal sum of _____
 for the payment of which, well and truly to be made, we hereby jointly and severally bind ourselves, successors
 and assigns.

Signed, this _____ day of _____, 2022.

The condition of the above obligation is such that whereas the Principal has submitted to the City of
 Pendleton a certain BID, attached hereto and hereby made a part hereof to enter into a Contract in writing for the
2022 URD Project - SE 3rd Street Water Line.

NOW THEREFORE,

(A) If said BID shall be rejected, or

(B) If said BID is accepted and the Principal executes and delivers contract in the Form of Contract attached hereto
 (properly completed in accordance with said BID) and furnishes a BOND for the faithful performance of said
 Contract, and for the payment of all persons performing labor or furnishing materials in connection therewith,
 and in all other respects perform the agreement created by the Acceptance of said BID,

then this obligation shall be void, otherwise the same shall remain in force and effect; it being expressly
 understood and agreed that the liability of the Surety for any and all claims hereunder shall, in no event, exceed
 the penal amount of this obligation as herein stated.

The Surety, for value received, hereby stipulates and agrees that the obligations of said Surety and its BOND
 shall be in no way impaired or affected by any extension of the time within which the Owner may accept such BID;
 and said Surety does hereby waive notice of any such extension.

IN WITNESS WHEREOF, the Principal and the Surety have hereunto set their hands and seals, and such of them as are corporations have caused their corporate seals to be hereto affixed and these presents to be signed by their proper officers, the day and year first set forth above.

Principal L.S.

Surety

By:_____
Attorney-in-Fact

IMPORTANT -- Surety companies executing BONDS must appear on the Treasury Department's most current list (Circular 570 as amended) and be authorized to transact business in the state where the project is located.



STATE OF OREGON
STATUTORY PUBLIC WORKS BOND

Surety bond #: _____ CCB # (if applicable): _____

We, _____, as principal, and

_____ a corporation qualified and authorized to do business in the State of Oregon, as surety, are held and firmly bound unto the State of Oregon for the use and benefit of the Oregon Bureau of Labor and Industries (BOLI) in the sum of thirty thousand dollars (\$30,000) lawful money of the United States of America to be paid as provided in ORS chapter 279C, as amended by Oregon Laws 2005, chapter 360, for which payment well and truly to be made, we bind ourselves, our heirs, personal representatives, successors and assigns, jointly and severally, firmly by this agreement.

WHEREAS, the above-named principal wishes to be eligible to work on public works project(s) subject to the provisions of ORS chapter 279C, as amended by Oregon Laws 2005, chapter 360, and is, therefore, required to obtain and file a statutory public works bond in the penal sum of \$30,000 with good and sufficient surety as required pursuant to the provisions of section 2, chapter 360, Oregon Laws 2005, conditioned as herein set forth.

NOW, THEREFORE, the conditions of the foregoing obligations are that if said principal with regard to all work done by the principal as a contractor or subcontractor on public works project(s), shall pay all claims ordered by BOLI against the principal to workers performing labor upon public works projects for unpaid wages determined to be due, in accordance with ORS chapter 279C, as amended by Oregon Laws 2005, chapter 360, and OAR Chapter 839, then this obligation shall be void; otherwise to remain in full force and effect.

This bond is for the exclusive purpose of payment of wage claims ordered by BOLI to workers performing labor upon public works projects in accordance with ORS chapter 279C, as amended by Oregon Laws 2005, chapter 360.

This bond shall be one continuing obligation, and the liability of the surety for the aggregate of any and all claims which may arise hereunder shall in no event exceed the amount of the penalty of this bond.

This bond shall become effective on the date it is executed by both the principal and surety and shall continuously remain in effect until depleted by claims paid under ORS chapter 279C, as amended by Oregon Laws 2005, chapter 360, unless the surety sooner cancels the bond. This bond may be cancelled by the surety and the surety be relieved of further liability for work performed on contracts entered after cancellation by giving 30 days' written notice to the principal, the Construction Contractors Board, and BOLI. Cancellation shall not limit the responsibility of the surety for the payment of claims ordered by BOLI relating to work performed during the work period of a contract entered into before cancellation of this bond.

IN WITNESS WHEREOF, the principal and surety execute this agreement. The surety fully authorizes its representatives in the State of Oregon to enter into this obligation.

SIGNED, SEALED AND DATED this _____ day of _____, 20 _____

Surety by:

Principal by:

_____ (Seal)
Company Name

Name

Signature

Signature

Title (e.g. Attorney-in-Fact)

Title

Address

Address

City State Zip

City State Zip

SEND BOND TO: Construction Contractors Board
PO Box 14140
Salem, OR 97309-5052
Telephone: (503) 378-4621



Construction Contractors Board

PO Box 14140
Salem OR 97309-5052
Telephone: 503-378-4621
Fax: 503-373-2007
Web Address: www.oregon.gov/ccb

For CCB Use Only:

File No. _____

Non-Construction Company

Filing STATUTORY PUBLIC WORKS BOND with CCB

ORS 279C.836 requires that all public works contractors working on qualifying public works projects, with a contract price that exceeds \$100,000, file a \$30,000 public works bond with the Construction Contractors Board (CCB). This includes construction companies that are licensed and non-construction companies that are not required to be licensed with the CCB.

If you are already licensed with the CCB, you do not need to complete this form. Please send your \$30,000 public works bond directly to the CCB with your license number on it.

If you are a non-construction company that is NOT required to be licensed with the CCB, please complete this information below and submit it with your \$30,000 public works bond. This will be used to help the CCB properly store and display your information on-line.

| | | | |
|---|--|--------------------------------------|--------------------------------------|
| Type of Business Entity: | | | |
| <input type="checkbox"/> Sole Proprietor | <input type="checkbox"/> Joint Venture | <input type="checkbox"/> Partnership | <input type="checkbox"/> Corporation |
| <input type="checkbox"/> LLC | <input type="checkbox"/> LP | <input type="checkbox"/> LLP | <input type="checkbox"/> Trust |
| Oregon Corporation Division Registry No. <i>(if applicable)</i> _____ | | | |
| Name of Business Entity: _____ | | | |
| Business Address: _____ | | | |
| Telephone No: (_____) _____ Email: _____ | | | |
| Type of Work This Company Performs: _____ | | | |

I certify that the aforementioned independent contracting business does not perform work subject to ORS 701 and is **NOT** required to be licensed with CCB.

| | |
|--|--------------------------------------|
| _____ | _____ |
| Name of Individual Filling Out This Form <i>(Please Print)</i> | Title/Position <i>(Please Print)</i> |
| _____ | _____ |
| Signature | Date |

Contract No. _____

CONTRACT FOR CONSTRUCTION

THIS CONTRACT, made and entered into this _____ day of _____, 2022, by and between the City of Pendleton, Oregon, a municipal corporation hereinafter called the "Owner" and _____ hereinafter called the "Contractor".

WITNESSETH:

Said Contractor, in consideration of the sum in the amount of \$_____ to be paid him by the Owner and of the covenants and agreements herein contained, hereby agrees at his own proper cost and expense to do all the work and furnish all the materials, tools, and labor for the construction of **2022 URD Project - SE 3rd Street Water Line.**

Contract Documents shall be referred to as Invitation to Bid, Information for Bidders, Prequalification, Bid Proposal, Bid Bond, Statutory Public Works Bond, Contract, Assignment of Anti-Trust Rights, Non-Collusion Affidavit, Performance and Payment Bond, Certificate of Insurance, Special Conditions, IRS Form W-9, Special Specifications, Drawings, all Addendum (if any) and the contents of the latest revision of the Oregon Standards Specifications for Construction (ODOT/APWA), excluding Sections 00100 and 00745.95 and the City of Pendleton Standard Specifications, and are all hereby made a part of this Contract by specific reference as fully and completely as if the same were fully set forth herein.

In the consideration of the faithful performance of the work herein embraced, as set forth in these Contract Documents, and in accordance with the direction of the Public Works Director (PWD) and to his satisfaction to the extent provided in the Contract Documents, the Owner agrees to pay to the Contractor the amount bid as adjusted in accordance with the proposals as determined by the Contract Documents, or as otherwise herein provided, and based on the said Proposal made by the Contractor, and to make such payments in the manner and at the times provided in the Contract Documents.

The Contractor agrees to indemnify and save harmless the Owner from any and all defects appearing or developing in the workmanship or materials performed or furnished under this Contract for a period of one (1) year after the acceptance by the Owner.

It is agreed that the time limit for the completion of the Contract, based upon the Proposal, is **no later than June 30, 2023.**

Contractor to note that if the water line is not installed before the local asphalt plants are closed for the season, then the Contractor shall temporarily patch with cold mix or Control Density Fill (CDF) at no additional cost to the Contract. The Contractor will be required to maintain the temporary patch until a final patch with hot mix asphalt can be installed. The final patch shall be installed by June 30, 2023, in order to avoid assessment of liquidated damages.

Contractor to note that if there are delays with water parts delivery that would cause the Contractor to miss the Contract Deadline, then the Contractor will need to provide proof from their Supplier regarding the delayed delivery, and the City will consider giving a contract timeline extension. If a contract timeline extension is granted, then the Contractor must complete the Project no later than forty-five (45) days after the final delivery of the parts.

In the event the Contractor shall fail to complete the work within the time limit or the extended time limit agreed upon, as more particularly set forth in the Contract Documents, liquidated damages shall be computed at the rate of one percent (1%) per calendar day of the total price of contract work not yet completed, or \$500.00 per calendar day, whichever is greater. Sundays and legal holidays excluded in determining days of default.

The Contractor shall not discriminate against any employee or applicant for employment because of sex, race, creed, color, or national origin.

IN WITNESS WHEREOF, we the parties hereto, each herewith subscribe the same this _____ day of _____, 2022.

CITY OF PENDLETON

By _____
John H. Turner, Mayor

By _____
A.F. Denton, City Recorder

(Contractor)

By _____
(Signature)

Title: _____

Approved as to Form: _____
Nancy Kerns, City Attorney

Contractor's Registration # _____

Contractor's Tax Identification # _____

ASSIGNMENT OF ANTITRUST RIGHTS

By entering into a contract, the Contractor, for consideration paid to the Contractor under the contract, does irrevocably assign to the City of Pendleton any claim for relief or cause of action which the Contractor now has or which may accrue to the Contractor in the future, including, at the City's option, the right to further assign any claim for relief or consideration and to control any such litigation on such claim for relief or counsel action, by reason of any violation of 15 USC 1-15 or ORS 646.725 or ORS 646.730, in connection with any goods or services provided to the Contractor by any person, which goods or services are used, in whole or in part, for the purpose of carrying out the Contractor's obligations under this contract.

In the event the Contractor hires subcontractors to perform any of the Contractor's duties under the contract, the Contractor shall require the subcontractor to irrevocably assign to the City of Pendleton, as a third party beneficiary any right, title or interest that has accrued or may accrue to the subcontractor by reason of any violation of 15 USC 1-15, ORS 646.725 or ORS 646.730, including, at the City's option, the rights to further assess any claim for relief or Counsel action and to control any litigation arising there under, in connection with any goods or services provided to the subcontractor's obligations as agreed to by the Contractor in pursuance of the completion of the contract.

In connection with this assignment, it is an express obligation of the Contractor that it will take no action which will in any way diminish the value of the rights conveyed or assigned hereunder to the City of Pendleton. It is an express obligation of the Contractor to advise the City of Pendleton of Oregon:

1. In advance, of its intention to commence any action on its own behalf regarding such claims for relief or causes of action;
2. Immediately upon becoming aware of the fact that an action has been commenced on its own behalf by some other person or persons, of the pendency of such action; and
3. The date on which it notified the obligator(s) of any such claims for relief or cause of action of the fact of its assignment to the City of Pendleton.

Furthermore, it is understood or agreed that in the event that any payment under any such claim is made to the Contractor, it shall promptly pay to the City of Pendleton its proportionate share thereof, if any, assigned to the State hereunder.

NON-COLLUSION AFFIDAVIT

- 1) This Non-Collusion Affidavit is material to any Contract awarded pursuant to the bid. According to the Oregon Public Contracts and Purchasing Laws, a public contracting agency may reject any or all bids upon the finding by the agency that it is in the public interest to do so (ORS 279.035). This public contracting agency finds that it is in the public interest to require the completion of this Affidavit by potential Contractors.
- 2) This Non-Collusion Affidavit must be executed by the member, officer, or employee of the Bidder who makes the final decision for price(s) and the amount(s) quoted in the bid.
- 3) Bid rigging and other efforts to restrain competition and the making of false sworn statements in connection with the submission of bids are unlawful and may be subject to criminal prosecution. The person who signs the Affidavit should examine it carefully before signing and assure themselves that each statement is true and accurate, making diligent inquiry, as necessary, of all other persons employed by or associated with the Bidder with responsibilities for the preparation, approval, or submission of the bid.
- 4) In the case of a bid submitted by joint venture, each party to the venture must be identified in the bid documents, and an Affidavit must be submitted separately on behalf of each party.
- 5) The term “complementary bid” as used in the Affidavit has the meaning commonly associated with that term in the bid process and includes the knowing submission of bids higher than the bid of another firm, any intentionally high or non-competitive bid, and any other form of bid submitted for the purpose of giving a false appearance of competition.
- 6) Failure to file an Affidavit in compliance with these instructions may result in disqualification of the bid.

STATE OF _____)
)
County of _____)

I state that I am _____, _____
Print/Type - Name Print/Type - Position Title with Firm/Company

representing _____
Print/Type - Name of Firm/Company

and that I am authorized to make this Affidavit on behalf of my Firm/Company, and its owners, directors, and/or officers. I am the person responsible in my Firm/Company for the price(s) and the amount(s) provided in this Proposal.

I state that:

- 1) The price(s) and the amount(s) provided in this bid have been arrived at independently and without consultation, communication, or agreement with any other Contractor, Bidder, or potential Bidder, except as disclosed on the attached appendix to this Non-Collusion Affidavit.
- 2) Neither the price(s) nor the amount(s) provided in this bid, and neither the approximate price(s) nor approximate amount(s) provided in this bid, have been disclosed to any other Firm/Company or person who is a Bidder or potential Bidder, and they will not be disclosed before the bid opening.
- 3) No attempt has been made or will be made to induce any Firm/Company or person to refrain from Bidding on this contract, or to submit a bid with price(s) and/or amount(s) higher than this bid, or submit any intentionally high or noncompetitive price(s) and/or amount(s) in a bid or other form of complementary bid.
- 4) The price(s) and/or amount(s) provided in this bid on behalf of my Firm/Company is made in good faith and not pursuant to any agreement or discussion with, or inducement from, any Firm/Company or person to submit a complementary or other non-competitive bid.
- 5) My Firm/Company, its affiliates, subsidiaries, officers, directors, and/or employees are not currently under investigation by a governmental agency. They have not in the last four years been convicted of or found liable for any act prohibited by State or Federal law in any jurisdiction, involving conspiracy or collusion with respect to Bidding on any public contract, except as described on the attached appendix to this Non-Collusion Affidavit.

I state that my Firm/Company understands and acknowledges that the representations are material and important and will be relied on by the City of Pendleton in awarding the Contract(s) for which this Bid is submitted.

I understand, and my Firm/Company understands, that any misstatement in this Affidavit is and shall be treated as fraudulent concealment from the City of Pendleton of the true facts relating to the submission of the Bid for this Contract(s).

Signature - Name

This instrument was acknowledged before me this _____ day of _____, 2022.

Notary Public for _____

My Commission Expires: _____

PERFORMANCE AND PAYMENT BOND

KNOW ALL MEN BY THESE PRESENTS, that we, _____

(The official name, form of organization, and address of the Contractor, and, if partnership, name of partners.)

as Principal, and _____
(Name and Address of the Surety)

_____, a corporation, duly authorized to do a general surety business in the State of Oregon as Surety, are jointly and severally held and bound unto City of Pendleton in the sum of _____
(the basic contract price, in words and figures)

for the payment of which we jointly and severally bind ourselves, our heirs, executors, successors, and assigns, firmly by these presents.

THE CONDITIONS OF THIS BOND ARE SUCH THAT

WHEREAS _____, the Principal herein, on the ____ day of _____, 2022, entered into a Contract with the City of Pendleton, the obligee herein, which Contract consists of:

Invitation to Bid, Information for Bidders, Prequalification, Bid Proposal, Bid Bond, Statutory Public Works Bond, Contract, Assignment of Anti-Trust Rights, Non-Collusion Affidavit, Performance and Payment Bond, Certificate of Insurance, Special Conditions, IRS Form W-9, Special Specifications, Drawings, all Addenda (if any), Oregon Standard Specifications for Construction (ODOT/APWA) latest revision, excluding Sections 00100 and 00745.95, and the City of Pendleton Standard Specifications

All as hereto attached and made a part hereof, whereby said Principal undertakes to do all labor, furnish all plant and equipment, and furnish all material in accordance with all the terms and conditions set forth in said Contract Documents; and promptly to make payment for all labor, services, and material and pay sums due the City of Pendleton and the United States required to be paid by employers and to save harmless the obligee from any claims for damages or injury to property or persons arising by reason of said work, as set out more fully in said Contract Documents; and to do and perform all things in said Contract Documents required, in the time and manner and under the terms and conditions therein set forth; and in conformity with all laws, state and national.

NOW, THEREFORE, if said Principal herein shall promptly pay all persons, furnishing labor, services, material or insurance to said Principal, or to his subcontractors, or to their assigns, on or about said work; and shall save harmless the Obligee, its officers and agents, from all claims therefore, or from any claim for damages of injury to property or persons arising by reason of said work; and shall in the time and manner, and under the terms and conditions prescribed, will and faithfully do, perform and furnish all material and things as by them in said contract undertaken, and as by law, state, and federal prescribed, then this obligation shall be void, but otherwise it shall remain in full force and effect.

PROVIDED, HOWEVER, that this bond is subject to the following further conditions:

- (a) All material, workmen, and all persons who shall supply such laborers, mechanics or subcontractors with material, supplies, or provisions for carrying on such work shall have a direct right of action against the Principal and Surety on this bond, second only to the right of the Obligee under this bond, which right of action shall be asserted in proceedings instituted in the appropriate court of the State of Oregon, and insofar as permitted by the laws of Oregon, such right of action shall be asserted in a proceeding instituted in the name of the Obligee to the use and benefit of the person, firm or corporation instituting such action and of all persons, firms, or corporations having claims hereunder shall have the right to be made a party to such proceeding (but not later than six months after the complete performance of said contract and final settlement and judgment rendered thereon).
- (b) In no event shall the Surety be liable for a greater sum than the amount of this bond, or subject to any suit, action, or proceeding thereon that is instituted later than twelve (12) months after the complete performance of said contract and final settlement thereof.
- (c) Said Surety, for value received, hereby stipulates and agrees that no change, extension of time, alteration, or addition to the terms of the contract or to the work to be performed thereunder or the specifications and accompanying the same shall in any way affect its obligations on this bond. It does hereby waive notice of such change, extension of time, alteration, or addition to the terms of the contract or to the work or to the specifications.

IN WITNESS WHEREOF, the parties hereto have caused this Bond to be executed in _____ this _____ day of _____, 2022.

_____(SEAL)

_____(SEAL)

_____(SEAL)
(Principal)

WITNESSES:

_____(SEAL)

_____(SEAL)

COUNTERSIGNED:

BY: _____
(Resident Agent)

ISSUE DATE _____

CERTIFICATE OF INSURANCE

This is to certify to the CITY OF PENDLETON that a CERTIFICATE OF INSURANCE is issued co-insuring the City of Pendleton as described below and that the insurer agrees that it shall notify the City in writing, of material change, or any expiration or of any cancellation of the below described policies not less than thirty (30) days prior to such change, expiration, or cancellation may become effective and that such notice shall be made by certified mail, return receipt requested, to the City of Pendleton at the following address: 500 S. W. Dorion Avenue, Pendleton, Oregon 97801.

Insured _____ COMPANIES AFFORDING COVERAGE
Company Letter A _____
Company Letter B _____
Company Letter C _____
Company Letter D _____
Company Letter E _____

COVERAGES

THIS IS TO CERTIFY THAT POLICIES OF INSURANCE LISTED BELOW HAVE BEEN ISSUED TO THE INSURED NAMED ABOVE FOR THE POLICY PERIOD INDICATED, THE INSURANCE AFFORDED BY THE POLICY DESCRIBED HEREIN IS SUBJECT TO ALL THE TERMS, EXCLUSIONS, AND CONDITIONS OF SUCH POLICIES EXCEPT WHERE, A CONTRACT BETWEEN THE INSURED AND THE CITY OF PENDLETON REQUIRES OTHERWISE.

TYPE OF INSURANCE (Check One) POLICY NUMBER POLICY EFFECTIVE DATE POLICY EXPIRATION DATE LIABILITY LIMITS IN THOUSANDS EACH OCCURRENCE AGGREGATE

Claims Made
Occurrence
GENERAL LIABILITY
COMPREHENSIVE FORM
PREMISES/OPERATIONS
UNDERGROUND
EXPLOSION & COLLAPSE
PRODUCTS/COMPLETED OPERATIONS
CONTRACTUAL
INDEPENDENT CONTRACTORS
BROAD FORM PROPERTY DAMAGE
PERSONAL INJURY
BODILY INJURY
PROPERTY DAMAGE
BI & PD COMBINED
PERSONAL INJ.

AUTOMOBILE LIABILITY
ANY AUTO
ALL OWNED AUTOS (PRIV. PASS.)
ALL OWNED AUTOS (OTHER THAN PRIV. PASS)
HIRED AUTOS
NON-OWNED AUTOS
GARAGE LIABILITY
BODILY INJURY (PER PERSON)
BODILY INJURY (PER ACCIDENT)
PROPERTY DAMAGE
BI & PD COMBINED

EXCESS LIABILITY
UMBRELLA FORM
OTHER THAN UMBRELLA FORM
BI & PD COMBINED

WORKER'S COMPENSATION AND EMPLOYERS' LIABILITY
STATUTORY
(each accident)
(disease policy limit)
(disease-each employee)

OTHER

DESCRIPTION OF OPERATIONS/LOCATIONS/VEHICLES/SPECIAL ITEMS

SPECIAL INSTRUCTIONS INDICATE WITH RESPECT TO EACH OF THE GENERAL CATEGORIES OF INSURANCE, IE. GENERAL LIABILITY, AUTO LIABILITY, EXCESS LIABILITY AND THE LIKE, WHETHER OR NOT THEY COVER THE BOXES ABOVE. SPECIFICALLY, THE CITY WANTS TO KNOW WHETHER BY CHECKING ONE OF THE BROAD COVERAGES ALL THE COVERAGES LISTED ARE ALSO INCLUDED. IN ADDITION, WITH RESPECT TO AGGREGATE LIMITS PLEASE INDICATE WHETHER THE AGGREGATES ARE FOR ONE OCCURRENCE OR AGGREGATE DURING THE LIFE OF THE POLICY WITH RESPECT TO EACH.

CERTIFICATE HOLDER CANCELLATION

This is to certify to the CITY OF PENDLETON that a CERTIFICATE OF INSURANCE is issued co-insuring the City of Pendleton as described below and that the insurer agrees that it shall notify the City in writing, of material change, of any expiration, of any cancellation of the below described policies not less than thirty (30) days prior to such change, expiration, or cancellation may become effective and that such notice shall be made by certified mail, return receipt requested, to the City of Pendleton at the following address: 500 SW Dorion Avenue, Pendleton, OR 97801.

AUTHORIZED REPRESENTATIVE _____

SPECIAL CONDITIONS

1. In the case of a difference or conflict in specifications and/or drawings, the Special Conditions, followed by the Special Specifications, followed by the City's Standard Specifications, and then followed by ODOT/APWA Specifications shall govern or prevail.
2. The Contractor shall make payment promptly, as due, to all persons supplying to such Contractor labor or materials for the prosecution of the work provided in the Contract.
3. The Contractor shall provide workers' compensation insurance coverage for all individuals, others than those exempt under ORS 656.027, who perform labor under the Contract before labor under the Contract commences. Contractor shall pay all contributions or amounts due for Workers' Compensation coverage from the Contractor incurred in the performance of the Contract.

A copy of each insurance policy, or certificate thereof, issued by a responsible and solvent insurance corporation or association authorized to issue such policy or policies under the laws of the State of Oregon shall be delivered to the City within a reasonable period of time after the same is issued by the company or companies or associations issuing such policy or policies. All said policies or certificates shall provide for a minimum of thirty (30) days notice to the City in the event of cancellation or material change in the terms.
4. The Contractor will not permit any lien or claim to be filed or prosecuted against the City on account of any material or labor furnished to the Contractor.
5. The Contractor will pay to the Oregon Department of Revenue all sums withheld from employees pursuant to Oregon Statutes.
6. The Contractor shall demonstrate that an employee drug testing program is in place.
7. If the Contractor fails, neglects, or refuses to make prompt payment of any claim for labor or services furnished to the Contractor or a subcontractor by any person in connection with this Contract as such claim shall become due, the proper officer or officers representing the City may pay such claim to the person furnishing the labor or service and charge the amount of the payment against funds due or to become due to the Contractor by reason of this Contract. The payment of a claim in this manner authorized by this paragraph shall not relieve the Contractor or the Contractor's surety from obligation with respect to any unpaid claim. (ORS 279C.515)
8. **The Contractor shall, within two (2) working hours after the advertised bid closing date and time, notify the Community Development Director in writing of the names of the first-tier sub-contractors on the disclosure form attached to the end of these Special Conditions.** Submission of the first-tier sub-contractors disclosure form only applies to public contracts for public improvements with a contract value of more than \$100,000 (ORS 279C.370). Contractors are required to disclose information about certain first-tier subcontractors. Specifically, when the contract amount of a first-tier subcontractor furnishing labor or labor and materials would be greater than or equal to: (i) 5% of the total project bid, but at least \$15,000; whichever is greater; or (ii) \$350,000 regardless of the percentage of the total project bid. **If no subcontractors need to be disclosed, enter "NONE" on the form and submit it.**
9. In addition to required payment and performance bonds which may be used for unpaid wages, all contractors, subcontractors and non-construction companies who work on public works projects, with a contract price that exceeds \$100,000, subject to the Prevailing Wage Rate law shall file a \$30,000 Statutory Public Works Bond with the Construction Contractor's Board (CCB) before starting work on the project, unless exempt, to be used exclusively for unpaid wages determined to be due by BOLI {ORS 279C.830 and ORS 279C.836}. **(See forms included in Section 7.00)** This bond applies to ALL CCB licensed and non-CCB licensed subcontractors. Contractors must include in every subcontract a provision requiring the subcontractor to have a Public Works Bond filed with the CCB and must verify that subcontractors have filed a Public Works Bond before permitting subcontractor to start work on a project, unless exempt. For more information regarding this requirement, contact the Construction Contractor's Board at (503) 378-4621.
10. If the Contractor fails, neglects or refuses to pay promptly a person's claim for labor or services that the person provides to the Contractor or a Subcontractor in connection with the public improvement contract as the claim becomes due, the proper officer that represents the municipality (Owner) may pay the amount of the claim to the person that provides the labor or services and charge the amount of the payment against funds due or to become due the Contractor by reason of the contract.

If the Contractor or a first-tier subcontractor fails, neglects or refuses to pay a person that provides labor or materials in connection with the public improvement contract within thirty (30) days after receiving payment from the contracting agency or a contractor, the contractor or first-tier subcontractor owes the person the amount due plus interest charges that begin at the end of the 10-day period within which payment is due under [ORS 279C.580 \(Contractor's relations with subcontractors\)](#) (4) and that end upon final payment, unless payment is subject to a good faith dispute as defined in [ORS 279C.580 \(Contractor's relations with subcontractors\)](#). The rate of interest on the amount due is nine (9) percent per annum as defined under ORS 279C.515(2). The amount of interest may not be waived.

11. If the Contractor or a subcontractor fails, neglects or refuses to make payment to a person furnishing labor or materials in connection with the public improvement contract, the person may file a complaint with the Construction Contractors Board, unless payment is subject to a good faith dispute as defined in ORS 279C.580. **Every contract related to this Contract shall contain a clause setting forth this requirement.**

12. If requested in writing by a first-tier subcontractor, the Contractor, within ten (10) calendar days after receiving the request, shall send to the first-tier subcontractor a copy of that portion of any invoice, request for payment submitted to the public contracting agency or pay document provided by the public contracting agency to the Contractor specifically related to any labor or materials supplied by the first-tier subcontractor.

13. Except where the Contractor is a party to a collective bargaining agreement in effect with a labor organization, no person shall be employed for more than ten (10) hours in any one day, or forty (40) hours in any one week, except in cases of necessity, emergency, or where the public policy absolutely requires it, and in such cases, the employee shall be paid at least time and a half pay:

- A) For all overtime in excess of eight (8) hours a day or forty (40) hours in any one week when the work week is five (5) consecutive days, Monday through Friday except for individuals under this Contract who are excluded under ORS 653.010 to 653.261 or under 29 U.S.C. sections 201 to 209 from receiving overtime; or
- B) For all overtime in excess of ten (10) hours a day or forty (40) hours in any one week when the work week is four (4) consecutive days, Monday through Friday; except for individuals under this Contract who are excluded under ORS 653.010 to 653.261 or under 29 U.S.C. sections 201 to 209 from receiving overtime; and
- C) For all work performed on Saturday and on the following legal holidays:
 - (i) Each Sunday.
 - (ii) New Year's Day on January 1.
 - (iii) Memorial Day on the last Monday in May.
 - (iv) Independence Day on July 4.
 - (v) Labor Day on the first Monday in September.
 - (vi) The afternoons of Wednesday and Thursday of the second full week in September (Round-up Week).
 - (vii) The Friday of the second full week of September (Round-up Week).
 - (viii) Thanksgiving Day on the fourth Thursday in November.
 - (ix) Christmas Eve on December 24.
 - (x) Christmas Day on December 25.
 - (xi) New Year's Eve on December 31.
- D) Each time a holiday listed above falls on Sunday, the succeeding Monday shall be recognized as a legal holiday. Each time a holiday listed above falls on Saturday, the preceding Friday shall be recognized as a legal holiday. (ORS 279C.540)
- E) The Contractor must give notice to employees who work on a public contract in writing, either at the time of hire or before commencement of work on the Contract, or by posting a notice in a location frequented by employees, of the number of hours per day and days per week that the employees may be required to work. (ORS 279C.520)

14. Contractor must promptly pay for all medical services for which the contractor has agreed to pay and for all amounts for which the Contractor collects or deducts from the worker's wages. (ORS 279C.530)

15. Each worker in each trade or occupation employed in the performance of the Contract either by the Contractor, subcontractor or other person doing or contracting to do the work in whole or any part on the Contract, shall be paid not less than the applicable prevailing rate of wage as required by ORS Chapter 279C.838 and 279C.840. All bidders must comply and agree that the requirements and conditions of employment be observed and prevailing wage rates, as established by the Oregon Bureau of Labor and Industries be paid under this Contract.

The existing prevailing wage rates in effect on July 1, 2022, including any amendments, are as published by the Oregon Bureau of Labor and Industries. Copies of the existing prevailing wages are available online at <https://www.oregon.gov/boli/employers/pages/prevailing-wage.aspx>

16. Any and all employees of Contractor or his contractors while engaged or performing any work or services required by him under this agreement shall be considered his employees only and not employees of the City and any claims that may arise under the Workers' Compensation Act on behalf of the said employees while so engaged in any and all claims made by third parties as a consequence of any act or omission on the part of him or his employees while so engaged on any of the work or services provided to be rendered herein shall be the sole obligation responsibility of Contractor and/or his contractors. The parties to this agreement recognize that Contractor and his employees, officers, agents and subcontractors are providing professional services as independent contractors and are not providing services as employees of the City and are therefore not entitled to the benefits provided by the City to his employees, including but not limited to Workers' Compensation benefits, group health insurance, social security, pension plans, or any other benefit accruing to City's employees. Contractor hereby agrees to hold the City harmless from, and shall process and defend at his own expense, all claims, demands, or suits of whatever nature, brought against him arising from his performance under this agreement. Contractor shall advise his officers, agents, employees and subcontractors of this provision.

17. The Contractor shall keep himself informed and at all times comply with any ordinance, laws, and regulations dealing with the preservation of environmental pollution and the preservation of natural resources that may be affected in the performance of the Contract. The following are a list of agencies that may have enacted ordinances or regulations dealing with the preservation and environmental pollution and the preservation of natural resources:

Federal Agencies:

Agriculture, Department of
Forest Service
Soil Conservation Service
Defense, Department of
Army Corps of Engineers
Energy, Department of
Federal Energy Regulatory Commission
Environmental Protection Agency
Health and Human Services, Department of
Housing and Urban Development,
Department of Solar Energy and Energy
Conservation Bank
Interior, Department of
Bureau of Land Management
Bureau of Indian Affairs
Bureau of Mines
Bureau of Reclamation
Geological Survey
Mineral Management Service
U.S. Fish and Wildlife Service
Labor, Department of
Occupational Safety and Health Administration
Mine Safety and Health Administration
Transportation, Department of
Coast Guard
Water Resources Council

State Agencies:

Administrative Services, Department of
Dept of Agriculture
Department of Consumer & Business Services,
State of Oregon
Occupational Safety & Health Division
Environmental Quality, Department of
Fish and Wildlife, Department of
Forestry, Department of
Geology and Mineral Industries, Department of
Health Division
Historic Preservation Office
Human Resources, Department of
Land Conservation and Development Commission
Parks and Recreation, Department of
Soil and Water Conservation Commission
State Engineer
State Land Board (Lands, Division of State)
Transportation, Department of
Water Resources Department

Local Agencies:

City of Pendleton City Council
Umatilla County Commissioners
Board of Port of Umatilla
Fire Protection Districts
City of Pendleton Planning Commission
Umatilla County Planning Commission
Confederated Tribes of the Umatilla Indian
Reservation

18. Liability and Indemnity:

- A) Indemnification. Contractor shall indemnify, hold harmless and defend City and its officers, agents and employees from, and reimburse City for, any cost, claim, loss, or liability suffered directly or from a third-party claim arising out of or related to any negligent activity of Contractor in the execution of this Contract. City shall have no liability to Contractor for any injury, loss, or damage caused by Contractor or third parties.
- B) Public Liability and Property Damage Insurance. Before beginning execution of the Contract, Contractor shall maintain public liability insurance against death or injury to person, or damage to property, during the life of this Contract at Contractor's cost; said insurance shall be in such form so as to protect both Contractor and City from all claims expressed or implied as above provided, and in the following amounts:
- 1) Public Liability Insurance not less than \$1,000,000 for injuries to any one person, including accidental death and not less than \$1,000,000 for any one accident.
 - 2) Property Damage Insurance not less than \$1,000,000 for any one accident.

The Contractor's Public Liability and Property Damage Insurance shall adequately provide the primary coverage on all claims arising out of the performance of the Contract. Such insurance shall cover all risks arising directly or indirectly out of Contractor's activities. Such insurance shall protect Contractor against the claims on account of the obligations assumed by Contractor under this Contract and shall name City and its officers, agents and employees as additional insured.

The above-mentioned proof shall be in the form of a copy of the policy and all appropriate riders with the City being named as a co-insured on all policies and provide for thirty (30) days written notice of any change or cancellation to City before Contractor begins execution of the Contract.

19. No bid for construction will be received or considered by the City unless the bidder is registered with the Construction Contractors Board as required by ORS Chapter 701 or the State Landscape Contractors Board as required by ORS 672.530. **In addition, the Contractor and subcontractors must obtain a City of Pendleton Business License as follows:**

- A) Any contractor or subcontractor engaged in any activity for which registration with the Oregon Construction Contractors Board is required pursuant to Oregon Revised Statutes, Chapter 701, must obtain a City of Pendleton Business License or comply with the alternative in paragraph 18.C) below.
- B) The Contractor or any subcontractor engaged in any activity for which registration with the Oregon Construction Contractors Board is required pursuant to Oregon Revised Statutes, Chapter 701, must include, as part of the application for a City of Pendleton business license, a copy of a current certificate of registration issued by the Oregon Construction Contractors Board.
- C) A prime contractor engaged in a Construction Project may obtain a Construction Project License as an alternative to obtaining a City of Pendleton Business License for each subcontractor engaged in the Construction Project. The Construction Project License is in lieu of a Business License for subcontractors only and is in addition to the Business License of the prime contractor. The application for a Construction Project License must contain, among other items, a signed statement by the prime contractor and each subcontractor engaged in the Construction Project that each signatory is registered under the provisions of this Oregon Revised Statutes, Chapter 701, and stating that the registration is in full force and effect. For the prime contractor and each subcontractor, a copy of a current certificate of registration issued by the Oregon Construction Contractors Board is also required.

20. The Oregon Government Standards and Practices laws may apply to Contractor. ORS 244.040(1)(a) prohibits any government officer, employee, or agent from using the governmental relationship to obtain a financial gain or avoid a financial detriment that would not otherwise be available but for the governmental relationship. For further information on this matter contact the Oregon Government Standards and Practices Commission; 100 High Street SE, Suite 220; Salem, Oregon 97310; phone 503 378-5105.

21. Contractor certifies that:

- A) Contractor is free from direction and control over the means and manner of providing the labor or services, subject only to the right of City to specify the desired results;
- B) Contractor is responsible for obtaining all assumed business registrations or professional occupational licenses required by state law or local governmental ordinances;
- C) Contractor furnishes the tools or equipment necessary for performance of the contracted labor or services;
- D) Contractor has the authority to hire and fire employees to perform the labor or services;
- E) Payment for the labor or services is made upon completion of the performance of specific portions of the project or is made on the basis of a periodic retainer;

- F) Contractor is registered under ORS chapter 701 (Construction Contractors), if Contractor provides labor or services for which such registration is required;
- G) Federal and state income tax returns in the name of the business or a business Schedule C or farm Schedule F as part of the personal income tax return were filed for the previous year if the contractor performed labor or services as an independent contractor in the previous year; and
- H) Contractor represents to the public that the Contractor is an independently established business. Except where Contractor files a Schedule F as part of the personal income tax return and the Contractor performs farm labor or services that are reportable on Schedule C, Contractor is considered to be engaged in an independently established business when four or more of the following circumstances exist:

[Initial those that apply]

- i ___ The labor or services are primarily carried out at a location that is separate from the residence of Contractor or are primarily carried out in a specific portion of the residence, which portion is set aside as the location of the business;
- ii ___ Commercial advertising or business cards as is customary in operating similar businesses are purchased for the business, or the Contractor has a trade association membership;
- iii ___ Telephone listing and service are used for the business that is separate from the personal residence listing and service used by Contractor;
- iv ___ Labor or services are performed only pursuant to written Contracts;
- v ___ Labor or services are performed for two or more different persons within a period of one year; or
- vi ___ Contractor assumes financial responsibility for defective workmanship or for service not provided as evidenced by the ownership of performance bonds, warranties, errors and omission insurance or liability insurance relating to the labor or services provided.

22. If any action is instituted in connection with any claim or controversy arising out of this agreement, attorney fees may not be awarded by the court of competent jurisdiction and each party shall bear its own expenses of such action.

23. This agreement and the party's rights under it shall be construed and regulated by the laws of the State of Oregon and venue for any dispute hereunder shall lie in Pendleton, Umatilla County, Oregon.

24. Work Hours

Normal working hours are Monday through Friday, 7:00 am to 5:00 pm. Work may extend beyond this time period with prior written permission from the City. The Contractor shall notify the City forty-eight (48) hours in advance of time work will be performed on Saturdays, Sundays or Holidays or other than normal working hours. **No customers shall have their water service interrupted before 8:00 am unless an emergency situation arises, or Contractor makes direct contact with said customer in advance.**

Per City Ordinance No. 2287, Section 26, no work that produces dust or flying debris shall be performed or equipment utilized that produces noise of sufficient volume to disturb the sleep or repose of occupants of neighboring property between the hours of 6:00 pm and 7:00 am without express written permission from the City.

25. The Contractor shall plan, coordinate and be responsible for all construction work and proceed with minimum interference to the operation of the existing facility or other construction work. Prior to starting the construction, confer with the City to develop an approved construction schedule, which will permit the facility to function as normal as practical during the construction. If it becomes necessary to do certain parts of the construction outside normal working hours, or change/modify sequence of activities in order to avoid undesirable conditions, it shall be the obligation of the Contractor to do this work at such a time at no additional cost to the City.

26. The Contractor shall maintain proper and required construction related impact controls, including controls for such impact as noise, dust, erosion and hours of operation.

27. The Contractor shall provide and receive written approval from the City of Pendleton a payment schedule prior to construction.

28. All existing features including, but not limited to, roadways, driveways/easements, structures, lots, curbs, sidewalks, fences, walls, plantings, ditches, mailboxes, signs, irrigation, piping and utilities disturbed during construction shall be restored to "AS GOOD or BETTER" than original condition unless otherwise specified in the plans/specifications. If a utility is damaged during construction, the Contractor shall contact owner of the utility for inspection of damage prior to repairs. Contractor shall repair all utility services damaged during construction, and such repair shall be considered incidental.

29. Recovery of Costs

As work on the Contract progresses, the City shall upon request, inform the Contractor of all accrued costs. If punch list items are not completed after the 12-month period following substantial completion, the City will retain the remaining retainage and consider the Contract closed. The City will complete the punch list items and any cost above the remaining retainage withheld will be sought by placing a lien against the Contractor's bond.

30. Final Payment

Upon completion of the work, Contractor shall notify City in writing that they have completed their part of the Contract and shall request Final Payment. Final Payment or any part of the retained percentage will be withheld upon the option of the City until the Contractor submits to the City an Affidavit Certifying Contractor Payment for Labor, Services and Materials, Compliance With Labor Provisions and Contractor's Acceptance of Final Payment. **(see Affidavit attached to end of this Section)**

31. Oregon's Reciprocal Preference Law

ORS 279A.120 requires public contracting agencies, in determining the lowest responsible bidder, to add a percent increase to each out-of-state bidder's bid price which is equal to the percent of preference given to local bidders in the bidder's home state. That is, if the low bidder is from a state that grants a 10 percent preference to its own in-state bidders, the Oregon agency must add 10 percent to that bidder's price when evaluating the bid.

ORS 279A.120(2) states: For the purposes of awarding a public contract, a contracting agency shall:

- (a) Give preference to goods or services that have been manufactured or produced in this state if price, fitness, availability and quality are otherwise equal; and
- (b) Add a percent increase to the bid of a nonresident bidder equal to the percent, if any, of the preference given to the bidder in the state in which the bidder resides.

The Department of Administrative Services (DAS), State Procurement Office has gathered information on preference laws of all states. For more information please visit:

<https://www.oregon.gov/DAS/Procurement/Pages/Index.aspx>

32. Each bid must identify whether the bidder is a resident bidder and each bidder must be qualified in accordance with ORS 279 and other applicable sections of the Oregon Revised Statutes in order to enter into a Contract with the Owner for public work in Oregon.

33. In-State Tie-Bid Awards

All state and local contracting agencies shall give preference to in-state offerors if their offers are the same as nonresident offerors.

34. Nonresident Bidders

ORS 279A.120(3) states: "When a public contract is awarded to a nonresident bidder and the contract price exceeds \$10,000, the bidder shall promptly report to the Department of Revenue (DOR) on forms to be provided by the department the total contract price, terms of payment, length of contract and such other information as the department may require before the bidder may receive final payment on the public contract. The contracting agency shall satisfy itself that the requirement of this subsection has been complied with before the contracting agency issues a final payment on a public contract." (See form attached to the end of these Special Conditions)

To view ORS 279A.120, visit: www.oregonlegislature.gov

For information about DOR requirements, contact: www.oregon.gov/DOR

35. Damage of existing structure - when the existing structure or facility, which is intended to remain, is damaged by the Contractor during demolition or construction, the Contractor shall promptly repair and replace the damaged portion of the facility at no cost to the City.

36. Street closures and notifications:

Streets may be closed as approved by City of Pendleton on a case-by-case basis. Overall work schedule must be submitted to and approved by City five (5) days prior to commencing work. Contractor will be responsible for all necessary signing and public notification and shall give written notification five (5) days prior and 24-hour advance notice to all residents and businesses along a street scheduled for road work and closure. This effort shall be incidental to the

Contract. Contact efforts should include, but not be limited to signage (**lettering should be easily legible from a vehicle and be at least 3 to 4 inch in size**), door knock and talks, letters, door hangars, and/or phone notifications, if possible. The notice shall describe the activity planned, when and if the street is to be closed, when it is scheduled to be reopened, and Contractor contact information.

City will publish schedule with local media to help with public notification. If bus stops/shelters are located within the project area which will impact the bus route, Contractor will coordinate with bus companies alternative temporary bus stops/shelters until completion of the project.

Public notification by the Contractor must also be sent to the following:

- First Student Bus Company
- Pendleton School District
- Kayak Public Transit
- Let 'er Bus Transit
- Pendleton Sanitary Service
- Umatilla County Dispatch
- Police Chief
- Fire Chief

Contact information for the above will be provided by the City at the pre-construction meeting.

DATED: _____, 2022.

Contractor: _____

By: _____

**CITY OF PENDLETON
FIRST-TIER SUBCONTRACTOR DISCLOSURE FORM**

Bids which are submitted by Bid Closing, but for which a required disclosure submittal has not been made by the specified Disclosure Deadline, are not responsive and shall not be considered for Contract award.

AGENCY SUPPLIED INFORMATION:

Project Name: 2022 URD Project - SE 3rd Street Water Line
 Bid Closing Date: October 11, 2022 Time: 2:00 p.m.
 Disclosure Deadline Date: October 11, 2022 Time: 4:00 p.m.

THIS DISCLOSURE FORM MUST BE SUBMITTED to the City of Pendleton at the location specified and in accordance with the date and time in the Advertisement for Bids. A separate form must be submitted for each Schedule. If necessary, use additional forms to satisfy the Disclosure requirements.

The contracting agency will insert "N/A" if the contract value is not anticipated to exceed \$100,000, otherwise, this form must be submitted either with the bid or within two (2) working hours after the advertised bid closing date and time; but no later than the Disclosure Deadline stated above.

List below the NAME, ADDRESS, DOLLAR VALUE, CONSTRUCTION CONTRACTOR BOARD (CCB) NUMBER, CONTACT NAME and TELEPHONE NUMBER of each Subcontractor that will be furnishing labor and/or materials that are required to be disclosed in accordance with ORS 279C.370.

ENTER "NONE" IF THERE ARE NO SUBCONTRACTORS THAT NEED TO BE DISCLOSED.
(Attach additional sheets if needed)

| <u>NAME/ADDRESS OF SUBCONTRACTORS</u> | <u>\$ VALUE/CCB #</u> | <u>CONTACT NAME/PHONE #</u> |
|---------------------------------------|------------------------|-----------------------------|
| 1) _____ _____ | \$ _____ CCB# _____ | _____ _____ |
| 2) _____ _____ | \$ _____ CCB# _____ | _____ _____ |
| 3) _____ _____ | \$ _____ CCB# _____ | _____ _____ |

The above listed first-tier subcontractor(s) are providing labor and/or materials with a Contract value equal to or greater than:

- a) 5% of the total project amount proposed or \$15,000, whichever is greater; or
- b) \$350,000, regardless of the percentage of the total project amount proposed.

Disclosure submitted by: _____
Signature – Bidder Name

Contact Name: _____
Print/type – Bidder Name Phone Number

Unless otherwise stated in the original solicitation, this document shall not be faxed. It is the responsibility of the Bidder to separately submit this Disclosure Form and any additional sheets with the Project Schedule and Name clearly marked in accordance with the date and time in the Advertisement for Bids.

CITY OF PENDLETON
AFFIDAVIT CERTIFYING CONTRACTOR PAYMENT FOR LABOR, SERVICES AND MATERIALS,
COMPLIANCE WITH LABOR PROVISIONS AND
CONTRACTOR'S ACCEPTANCE OF FINAL PAYMENT

(READ THIS DOCUMENT CAREFULLY. IT IS A LEGAL DOCUMENT)

PROJECT NAME: _____ CONTRACT NO. _____

I, _____ the _____
(Name) (Officer/Title)
of _____ acknowledge:
(Company)

1. That all labor, services, materials furnished for the above Contract have been paid in full.
2. That I and my subcontractors, employees, agents and officials have complied with all labor provisions of the above Contract, and all final Certified Payroll Reports have been submitted to the City of Pendleton.
3. That there are no claim(s), potential claim(s) or pending claim(s) for any labor, services or materials related to this Contract.
4. That there are no liens, potential liens or pending liens existing related to this Project and/or to the above Contract.
5. That I have reviewed the attached final pay statement and it is a true and accurate statement for final payment for all labor, services and materials of the above Contract.
6. That all work (labor and/or services) has been performed and/or material supplied in full accordance with the requirements of the above Contract, except for those modifications approved by the City in writing including: duly authorized written deviations, written substitutions, written alterations and/or written additions.
7. That I accept final payment for all labor, services and materials furnished pertinent to the above Contract and that I release the City of Pendleton, an Oregon municipal corporation and its officers, agents and employees from any and all claims and any and all liabilities to me as the Contractor for all things done or furnished in connection with the Contract and agree to defend and indemnify the City of Pendleton against any and all claims, loss, damage or liability made against the City by Contractor, his employees, agents, subcontractors or those acting within his authority and every act of the City related to or rising out of the Contract.
8. That I have provided a performance bond for the Contract, which shall remain in full force and effect for one (1) year after the date of final written acceptance by the City of the work, and this performance bond guarantees any and all workmanship and materials from any defect whatsoever.
9. That I have read this Affidavit and agree with it.

DATED this _____ day of _____, 20__.

Contractor's Name

Print Name and Title

Signature

State of _____)

)

County of _____)

On the _____ day of _____, 20__, personally appeared _____
as _____ of _____, Contractor,
who acknowledged this instrument to be his/her voluntary act and deed.

(SEAL)

Notary Public – State of _____

My Commission Expires: _____

Form OR-NRB

Page 1 of 1, 150-800-020 (Rev. 03-17) Oregon Department of Revenue

| |
|-----------------|
| Office use only |
| Date received |
| |

Oregon Nonresident Bidder Form

Submit original form—do not submit photocopy.

Oregon Revised Statute (ORS) 279A.120 states that when a public contract is awarded to a nonresident bidder and the contract price is more than \$10,000, the bidder must report certain information to the Oregon Department of Revenue before the bidder can receive final payment on the contract. To view ORS 279A.120, visit www.oregonlegislature.gov.

Using one of the options below, you must submit this completed form before we can make your final payment.

A. Bidder information

| | | |
|-------------------------|-------|----------------------------|
| Company name | | Federal ID number |
| Company contact name | | Oregon business ID number |
| Street/mailling address | | Telephone () - |
| City, state, ZIP | Email | |

B. Contract information

| | | |
|---|-------------------------------|---------------------------------|
| Contracting agency name | | |
| Terms of payment | Total contract price \$ | |
| Brief description of services provided | | |
| Will the work or services provided, at any time, require a physical presence in Oregon? <input type="checkbox"/> Yes <input type="checkbox"/> No | | |
| Contract number | Start date of contract / / | Contract expiration date / / |
| Agency contact | | |

C. Submitting this form

Please submit this form one of these ways:

| Mail | Fax | Email |
|---|--------------|--|
| Oregon Department of Revenue Financial Services Unit 955 Center Street NE, Room 461 Salem OR 97301 | 503-945-8382 | dor.procurement@state.or.us <i>(You must have Acrobat Standard or Professional to use this option)</i> |

Name of person signing for business _____ Title _____

Signature of person signing for business _____ Date _____

Request for Taxpayer Identification Number and Certification

Give Form to the requester. Do not send to the IRS.

▶ Go to www.irs.gov/FormW9 for instructions and the latest information.

1 Name (as shown on your income tax return). Name is required on this line; do not leave this line blank.

2 Business name/disregarded entity name, if different from above

3 Check appropriate box for federal tax classification of the person whose name is entered on line 1. Check only **one** of the following seven boxes.

Individual/sole proprietor or single-member LLC C Corporation S Corporation Partnership Trust/estate

Limited liability company. Enter the tax classification (C=C corporation, S=S corporation, P=Partnership) ▶ _____

Note: Check the appropriate box in the line above for the tax classification of the single-member owner. Do not check LLC if the LLC is classified as a single-member LLC that is disregarded from the owner unless the owner of the LLC is another LLC that is not disregarded from the owner for U.S. federal tax purposes. Otherwise, a single-member LLC that is disregarded from the owner should check the appropriate box for the tax classification of its owner.

Other (see instructions) ▶ _____

4 Exemptions (codes apply only to certain entities, not individuals; see instructions on page 3):

Exempt payee code (if any) _____

Exemption from FATCA reporting code (if any) _____

(Applies to accounts maintained outside the U.S.)

5 Address (number, street, and apt. or suite no.) See instructions. Requester's name and address (optional)

6 City, state, and ZIP code

7 List account number(s) here (optional)

Print or type.
See Specific Instructions on page 3.

Part I Taxpayer Identification Number (TIN)

Enter your TIN in the appropriate box. The TIN provided must match the name given on line 1 to avoid backup withholding. For individuals, this is generally your social security number (SSN). However, for a resident alien, sole proprietor, or disregarded entity, see the instructions for Part I, later. For other entities, it is your employer identification number (EIN). If you do not have a number, see *How to get a TIN*, later.

Note: If the account is in more than one name, see the instructions for line 1. Also see *What Name and Number To Give the Requester* for guidelines on whose number to enter.

Social security number

| | | | | | | | | | | | |
|--|--|--|---|--|--|---|--|--|--|--|--|
| | | | - | | | - | | | | | |
|--|--|--|---|--|--|---|--|--|--|--|--|

or

Employer identification number

| | | | | | | | | | | | |
|--|--|--|---|--|--|--|--|--|--|--|--|
| | | | - | | | | | | | | |
|--|--|--|---|--|--|--|--|--|--|--|--|

Part II Certification

Under penalties of perjury, I certify that:

- The number shown on this form is my correct taxpayer identification number (or I am waiting for a number to be issued to me); and
- I am not subject to backup withholding because: (a) I am exempt from backup withholding, or (b) I have not been notified by the Internal Revenue Service (IRS) that I am subject to backup withholding as a result of a failure to report all interest or dividends, or (c) the IRS has notified me that I am no longer subject to backup withholding; and
- I am a U.S. citizen or other U.S. person (defined below); and
- The FATCA code(s) entered on this form (if any) indicating that I am exempt from FATCA reporting is correct.

Certification instructions. You must cross out item 2 above if you have been notified by the IRS that you are currently subject to backup withholding because you have failed to report all interest and dividends on your tax return. For real estate transactions, item 2 does not apply. For mortgage interest paid, acquisition or abandonment of secured property, cancellation of debt, contributions to an individual retirement arrangement (IRA), and generally, payments other than interest and dividends, you are not required to sign the certification, but you must provide your correct TIN. See the instructions for Part II, later.

Sign Here Signature of U.S. person ▶ _____ Date ▶ _____

General Instructions

Section references are to the Internal Revenue Code unless otherwise noted.

Future developments. For the latest information about developments related to Form W-9 and its instructions, such as legislation enacted after they were published, go to www.irs.gov/FormW9.

Purpose of Form

An individual or entity (Form W-9 requester) who is required to file an information return with the IRS must obtain your correct taxpayer identification number (TIN) which may be your social security number (SSN), individual taxpayer identification number (ITIN), adoption taxpayer identification number (ATIN), or employer identification number (EIN), to report on an information return the amount paid to you, or other amount reportable on an information return. Examples of information returns include, but are not limited to, the following.

- Form 1099-INT (interest earned or paid)

- Form 1099-DIV (dividends, including those from stocks or mutual funds)
- Form 1099-MISC (various types of income, prizes, awards, or gross proceeds)
- Form 1099-B (stock or mutual fund sales and certain other transactions by brokers)
- Form 1099-S (proceeds from real estate transactions)
- Form 1099-K (merchant card and third party network transactions)
- Form 1098 (home mortgage interest), 1098-E (student loan interest), 1098-T (tuition)
- Form 1099-C (canceled debt)
- Form 1099-A (acquisition or abandonment of secured property)

Use Form W-9 only if you are a U.S. person (including a resident alien), to provide your correct TIN.

If you do not return Form W-9 to the requester with a TIN, you might be subject to backup withholding. See What is backup withholding, later.

SPECIAL SPECIFICATIONS

PROJECT OVERVIEW

SE 3RD STREET WATER MAIN REPLACEMENT

The purpose of this Project is to install 740 linear feet (LF) of 18-inch water main and 640 LF of 12-inch water main on SE 3rd Street from the cul-de-sac north of SE Byers Avenue to SE Frazer Avenue. The new 12-inch water main will connect to two (2) existing 12-inch water mains in the cul-de-sac and extend to SE Byers Avenue and make a connection with a 12-inch water main the City has already installed. New 12-inch water main will be installed between SE Byers Avenue and SE Court Avenue with 12- and 18-inch connections to existing. New 18-inch water main will be installed between SE Court Avenue and SE Dorion Avenue and between SE Dorion Avenue and SE Emigrant Avenue with 18-inch connections to existing. A new fire hydrant will be installed at the cul-de-sac and a fire hydrant will be replaced at the SE corner of SE Court Avenue. The Contractor shall have the option of installing PVC or ductile iron water line of the type and class specified in the Proposal.

The City will tap the water main for the water services; however, the Contractor will be required to dig and backfill trenches and must coordinate with City crews to install the service. The Contractor will be required to make connections and install the 6-inch fire service lines. The City will provide specific fittings for this project. Fittings supplied by the City are identified on the Proposal. The Contractor shall be required to provide all other materials including the MegaLug restraints required for the MJ fittings the City provides.

Contractor to note the crossing over the sewer main shall conform to OAR 333-061-0050(9).

All fittings shall be restrained using either thrust blocks or restrained joints of sufficient length back from each fitting per manufacturer’s recommendation and Engineer’s approval. Thrust blocks or restrained joints shall be incidental to the project. All necessary water shut-off/turn on, shall be performed and coordinated with the City. Perform additional and incidental work as called for in the Specifications and Plans.

The City is offering the use of a storage basin located at the Wastewater Treatment Plant (see sheet 13) to haul and dispose of spoils related to this project. **Only fill with native rock and dirt will be allowed. Asphalt and concrete must be separated.**

1. ALL CONSTRUCTION

All construction shall be in compliance with the latest revision of the City of Pendleton Standard Specifications and the “Oregon Standard Specifications for Construction” (ODOT/APWA) latest revision, excluding Sections 00100 and 00745.95, unless otherwise noted in these special specifications.

2. STANDARDS APPLICABLE TO CONSTRUCTION

The following specifications shall be included by this reference as they may apply to this project. The most current versions of these specifications, which were in effect at the time of the first publication of the Advertisement for Bid, are applicable.

- A.1 AASHTO -American Association of State Highway & Transportation Officials
- A.2 ACI -American Concrete Institute
- A.3 AISI -American Iron and Steel Institute
- A.4 ANSI -American National Standards Institute
- A.5 APWA -American Public Works Association
- A.6 ASME -American Society of Mechanical Engineers
- A.7 ASTM -American Society for Testing and Materials
- A.8 AWWA -American Water Works Association
- A.9 AWA -American Welding Society
- A.10 AWPA -American Wood Preservers Institute
- A.11 CSAA -Coating Standards Association
- A.12 CRSI -Concrete Reinforcing Steel Institute
- A.13 FWHA -Federal Highway Administration

- A.14 HI -Hydraulic Institute
- A.15 IEEE -Institute of Electrical & Electronic Engineers
- A.16 ICEA -Insulated Cable Engineers Association
- A.17 NBS -National Bureau of Standards
- A.18 NACE -National Association of Corrosion Engineers
- A.19 NEC -National Electric Code
- A.20 NEMA -National Electric Manufacturer's Association
- A.21 NLMA -National Lumber Manufacturer's Association
- A.22 OSHD -Oregon State Highway Department
- A.23 PCA -Portland Cement Association
- A.24 SPFA -Steel Plate Fabricators Association
- A.25 SSPC -Steel Structures Painting Council
- A.26 UL -Underwriters Laboratories, Inc.
- A.27 UBC -Uniform Building Code
- A.28 WWPA -Western Wood Products Association
- A.29 All applicable governmental building codes. Use of the "Call Before You Dig" locate service and construction specifications in effect at the time of the first Advertisement for Bids. Where conflicts occur between the different specifications, these special specifications shall prevail over the above-cited specifications, followed by the City's Standard Specifications then the Oregon Standard Specifications for construction. As a general rule, the most stringent specification for any conflicting specifications shall prevail. Any interpretation required of the specifications shall be referred to the City Engineer. Response shall be in writing and final.

3. HOURS OF WORK

The Contractor shall notify the City forty-eight (48) hours in advance of time worked that will be performed on Saturdays, Sundays or Holidays, or other than normal working hours. Normal working hours are 7:00 am to 5:00 pm. Per City of Pendleton Street Excavation Ordinance No. 2287, Section 26, hours of work are limited to 7:00 am – 6:00 pm without a waiver granted by the City Manager. **No customers shall have their water service interrupted before 8:00 am unless an emergency situation arises, or Contractor makes direct contact with said customer in advance.**

4. PERMITS AND LICENSES

The Contractor shall keep himself informed of all local ordinances, state, and federal laws in any manner affecting the work. All permits and licenses necessary for the prosecution of this work shall be secured and paid for by the Contractor. All persons engaged in business in fulfillment of this Contract must have a valid City of Pendleton Business License or the Contractor must have a valid Construction Project License for this project.

5. SCHEDULING

Contractor will be required to submit a project schedule five (5) days prior to construction and shall update and resubmit the project schedule every two (2) weeks to the City's Project Manager.

6. UNCLASSIFIED EXCAVATION/TRENCHING

All excavation or trenching material shall be unclassified material regardless to type, nature, characteristic, and/or condition of the material to be encountered, and is considered incidental to the installation of the water line unless the material meets the criteria below in Section 7- Rock Excavation. The Contractor, by signing the Proposal, has certified that they have carefully examined the Plans and work site; that they have satisfied themselves as to the nature and location of the work, quality and quantity of material required and the character of equipment and facilities needed to accomplish the work; and they have included any costs associated with the extra effort of excavating unclassified material in the cost of lineal foot of utility trenches, water pipe installed. Contractor is responsible for compaction of all trench backfill. Trench excavation and backfill is considered incidental to the installation of the water line.

7. ROCK EXCAVATION

Rock excavation shall include the additional cost, per cubic yard, required to fragment and excavate rock with a 330 class excavator or larger, a D-8 Caterpillar dozer with rippers, or a rock saw. Additional equipment brought onto the job site for this item shall be paid per cubic yard of excavated material as a part of the unit bid item for "Rock Excavation". A minimum 48-hour notification by the Contractor to the City shall be required prior to any rock excavation. Rock excavation is not anticipated for this project. If it is necessary payment for this item shall be by

force account for the additional cost to excavate the rock, as described above, beyond the incidental effort to excavate, install the water line, and place and compact backfill, and shall include, but not be limited to, all rock excavation, labor, equipment and tools necessary for a complete and approved job according to plans and as directed by the Engineer.

8. NOTIFICATIONS

The Contractor shall make every effort possible to contact adjoining property owners of streets scheduled for road work. This effort shall be incidental to the Contract. Contact efforts should include, but not be limited to signage (**lettering should be easily legible from a vehicle and be at least 3 to 4 inch in size**), door knock and talks, letters, door hangars, and/or phone notifications, if possible. Contractor shall give written notification five (5) days prior and 24-hour advance notice to all residents and businesses along a street scheduled for road work. The notice shall describe the activity planned, when and if the street is to be closed, when it is scheduled to be reopened, and Contractor contact information. Overall work schedule must be submitted to and approved by City five (5) days prior to commencing work. City will provide schedule to local media to help with public notification.

9. TRAFFIC CONTROL

If parked vehicles obstruct the progress of work after an appropriate notification of closure, requests for removal of the obstructive vehicles should be made through the City of Pendleton. The City will need a minimum of four (4) hours notice to have vehicles removed.

In addition to other requirements as set forth in the Special Conditions, other provisions shall include, but not be limited to:

- a) The Contractor shall at all times maintain such flagmen, signs, lights, barricades and other safety devices, all necessary to ensure the safety and convenience of the public and its employees, and to protect the work.
- b) The Contractor will insure that during non-working hours, that on-call staff is available to maintain all traffic control devices for the project. The Contractor shall provide the City of Pendleton with up-to-date information of these persons. Failure to comply with the provision will cause the Contractor to be billed for any services required to be provided by the City of Pendleton, to provide adequate protection to the traveling public during non-working hours.
- c) Traffic control and temporary protection and correctional devices shall be used outside the limits of the project when they have direct bearing or reference on the work under contract.
- d) The Contractor shall at all times keep the road under construction and routes used for hauling the material, that are open to traffic, free from mud, rock and other debris that may create traffic hazards, and shall provide adequate personnel to alleviate any danger. Roads shall be inspected and cleaned of any such debris at the close of every working day, or as often as deemed necessary by the City. On streets that are not closed at the end of the day, the Contractor shall leave the road in such condition that the streets that are open to traffic can be traveled without damage to work, personal property, or without danger to the public.
- e) The Contractor will be concerned with the following factors in restricting traffic flow. The approved traffic control and channelization plan, emergency vehicle access, permissible hours of restriction, sufficient traffic control personnel and devices, prior warning to public residents and a minimum forty-eight (48) hours advance notification to the City.

The City may direct the Contractor to provide additional traffic control devices to assure the safety of pedestrian and vehicular traffic, as the City deems necessary. It shall be the responsibility of the Contractor to move, replace, position, or remove any sign as required due to the change of work schedule due to weather or other unforeseen circumstances.

10. SURVEYING

The City will provide surveying layout with locations, and/or offsets of all angle points, tees, valves, and 100-foot stations, if needed. Contractor must give 48 hour notice to the City for surveying. Contractor will be responsible to protect survey stakes once placed. Contractor may be billed for re-staking if means of protection were not administered.

11. **WATER MAINS**

C-905 pipe shall conform to the requirements of AWWA standards for Pressure Class 235 psi (DR 18). All C-900/C-905 pipe shall be "Polyvinyl Chloride (PVC) Water Distribution Pipe" and installed per manufacturer's recommendations. Pipe shall be made of quality PVC resin, compounded to provide physical and mechanical properties that equal or exceed cell class 12454 as defined in ASTM D 1784. The joint design shall meet the requirements of ASTM D 3139 under both pressure and 22 in. Hg vacuum. Gaskets shall meet ASTM F477. All fittings shall be D.I. type. Ductile iron pipe shall be class 50/52 as specified and shall conform to ASTM A 536, ANSI A 21.51, and AWWA C 151. Solid walled HDPE pipe shall meet ANSI/AWWA C906, Standard PE Code Designation PE 3408, and minimum cell classification PE 334434C (ASTM D3350) or approved similar. Contractor to note that there shall be a minimum of 3-foot cover from top of pipe. Measurement for payment shall be per lineal foot of water main installed including trenching, bedding, and Class "B" compacted backfill, and passing the specified tests. The Contractor shall disinfect and flush the water main for the chlorine residual and bacteriological tests per Section 3.03-J of the City Standards prior to performing the pressure test. The Contractor shall provide all required materials and equipment to disinfect the line and shall coordinate with the City to disinfect the line and to perform the chlorine residual and bacteriological tests. The City will take water samples for the chlorine residual and bacteriological tests and deliver them to the lab. Following a successful chlorine residual and bacteriological test, the Contractor shall coordinate with the City to perform the pressure test as specified in Section 3.03-I of the City standards. The Contractor is responsible for providing all necessary equipment to perform the pressure test. Payment for this item shall include, but not be limited to, all piping, trench excavation and backfill, shoring, bedding material, locate wire, select backfill, installation of miscellaneous bends and fittings, thrust restraints, testing, and all labor, equipment and tools necessary for a complete and approved job in place according to plans and as directed by the Engineer.

- a) **Notification:** Contractor shall make every effort possible to contact adjoining property owners of streets scheduled for water service interruption. This effort shall be incidental to the Contract. Contact efforts should include, but not be limited to signage (**lettering should be easily legible from a vehicle and be at least 3 to 4 inch in size**), door knock and talks, letters, door hangars, and/or phone notifications, if possible. Contractor shall give written notification five (5) days prior and 24-hour advance notice to all residents and businesses along a street scheduled for water service interruption. The notice shall describe the activity planned, when and if the street is to be closed and when it is scheduled to be reopened, and Contractor contact information. Contractor overall work schedule must be submitted to and approved by City five (5) days prior to commencing work. City will provide schedule to local media to help with public notification.
- b) **Locate Wire:** All new pipe materials shall have solid blue #12 AWG locate wire for water. The locate wire shall be continuous and attached to the top of all pipe buried in a trench or casing, whether the pipe is DI, C-900, PEX, copper, PVC, ABS, or HDPE, and all risers, with a minimum 6-inch length of duct tape at a maximum of 10-foot intervals, with enough wire brought to the surface at every valve, hydrant, blow off, air release valve, meter, clean out, catch basin, and manhole to extend a minimum 6-inches above finished grade unless otherwise noted. All splices shall be overlapped and tied. The splice connection shall be made waterproof with an approved silicone splice kit. Splice kit shall be 3M-direct bury splice kit DBR/Y-6 or pre-approved equal. Locate wire shall be tested after being buried but before finished grade is established or patching is performed.
- c) **Water Service Trench Installation:** Contractor shall trench for the City. The City will tap the main, install the corp stop and copper line to the meter setter. The City is responsible for supplying the saddle tap, corp stop, copper line, and parts associated with the meter. Contractor is responsible for trenching, bedding, backfilling and compacting the water service trench. Payment of this item shall include all labor, tools, equipment, and materials necessary for a complete and approved job.
- d) **Water Valves:** Valves shall be resilient wedge, non-rising stem with "O" ring packing, complying with AWWA C509 or C515-99. The valves shall withstand a working pressure of 200 psi or greater. The valve shall be furnished with a two-inch (2") square operating nut and shall open counter-clockwise when viewed from above. Valves shall be epoxy coated inside and out, complying with AWWA C550. This item shall include, but not be limited to, installation of approved valve casing and lid, all labor, equipment and tools necessary for a complete and approved job. All valve boxes located in the roadway or highly vegetated areas shall have concrete collars around the valve box frame. See City standard drawing 402.
- e) **Fire Hydrants:** Fire Hydrants shall meet the City of Pendleton Standards. This item shall include, but not be limited to, installation of approved fire hydrant, all labor, equipment, and tools necessary for a complete and approved job. See City standard drawing 400.

- f) **Connection to Existing Water Main:** The connection of existing water mains shall be made on a clean, strong existing pipe. Extreme care shall be taken by the Contractor to keep the existing water lines, new fittings and water line clean and free of contaminants. The inside surface of valve, pipe, and fittings shall be thoroughly swabbed with or filled with a 75 part per million chlorine solution in accordance with AWWA C651, Section 9 prior to the installation of all fittings. This item shall include, but not limited to, all labor, equipment, and tools necessary for a complete and approved job.
- g) **Valve Box Adjustment:** Contractor will supply materials to adjust water valves boxes as necessary. Water valves shall be raised according to City of Pendleton Standard Drawing 402. Contractor is responsible for the actual adjustment of the utility. Any lost or broken materials will be furnished by the City of Pendleton.
- h) **Pipe Bedding and Backfill:** Water mains and services shall have a minimum of 4" (compacted depth) of ¾" - 0" pipe bedding below the water pipe and a minimum of 12" compacted depth of ¾" - 0" cover over the top of the water pipe, measured at the top of pipe. Native material may be used to continue the backfill in "non-traveled" ways. Within roadways, the trench shall be backfilled with Class B material per Oregon Standard Specification 00405.14, properly compacted to a minimum density of 95%, or approved equal. 3/4" - 0" base rock may be substituted for the Class B backfill material. Payment of pipe bedding and backfill shall be incidental to "C-900/C905 Water Main or Class 50/52 DI", and Water Service Trench items and shall include all labor, tools, equipment, and materials necessary for a complete and approved job.
- i) **Asphalt Patch:** Asphalt patching shall include saw cutting or zipping to a neat edge and removal of the existing asphalt pavement, placement of compacted base to 95% of maximum density to the depth specified on the drawings, and placing Level 3 HMAC compacted to 95% density to the depth specified on the drawings. Payment of this item shall include all labor, tools, equipment, and materials necessary for a complete and approved job.

12. REMOVAL AND REPLACEMENT OF CONCRETE CURB AND GUTTER

Curb and gutter shall meet City of Pendleton standards. Price per foot shall include but not be limited to: saw cut of existing curb, removal and disposal of existing, excavation and grading, 2" minimum compacted base rock under curb and gutter, all forms, pouring and finishing work. The Contractor shall match the type of landscaping adjacent to the structure or that was pre-existing. If an irrigation system is impacted in any way, Contractor will cap affected area and notify property owner immediately (within the hour). If related to form work, once forms are removed, Contractor will re-establish fully functioning irrigation system to "AS GOOD or BETTER" within 24-hours of forms being pulled and notify property owner of repair by the close of the work day.

13. REMOVAL AND REPLACEMENT OF CONCRETE SIDEWALK

Sidewalk shall meet City of Pendleton standards. Price per square yard shall include but not be limited to: saw cut of existing, removal and disposal of existing, excavation and grading, installation of compacted base rock under sidewalk and driveway approaches, all forms, pouring and finishing work. Any excess spoils shall be hauled to an offsite location at no additional cost.

There shall be a minimum of 4" of ¾" minus crushed base rock, and the base rock shall be compacted to not less than 95% relative compaction. Sidewalks shall be constructed using 5 sack concrete mix having a minimum compressive strength of 3000 psi, 28 days after placement and a slump range of 3" to 5". Sidewalks shall have a minimum concrete thickness of 4".

14. REMOVAL OF CURB AND GUTTER AND REPLACEMENT WITH ASPHALT CURB AND GUTTER

Price per foot shall include but not be limited to: saw cut of existing curb, removal and disposal of existing, excavation and grading, 4" minimum compacted base rock under curb and gutter, Level 3 HMAC, placing and finishing work. The Contractor shall match the type of landscaping adjacent to the structure or that was pre-existing. If an irrigation system is impacted in any way, Contractor will cap affected area and notify property owner immediately (within the hour). Contractor will re-establish fully functioning irrigation system to "AS GOOD or BETTER" and notify property owner of repair by the close of the workday.

15. REMOVAL OF SIDEWALK AND REPLACEMENT WITH ASPHALT PATCH

Price per square yard shall include, but not be limited to: saw cut of existing, removal and disposal of existing, excavation and grading, installation of compacted base rock under sidewalk, Level 3 HMAC, all forms, placing and finishing work. Any excess spoils shall be hauled to an offsite location at no additional cost. There shall be a minimum of 4" of ¾" minus crushed base rock, and the base rock shall be compacted to not less than 95% relative compaction.

16. EXISTING FITTING, FIRE HYDRANTS, VALVE BOXES, OR BUTTERFLY/GATE VALVE REMOVAL

This item shall include the removal of the existing fitting, fire hydrants, valve boxes, or butterfly/gate valves, all restrained joints, if any, and/or thrust blocks. Care shall be given to not damage the existing fitting or butterfly valve during the removal. The fittings, fire hydrants, or butterfly/gate valves shall be returned to the City and delivered to City shops.

17. DISCONNECT, PLUG, AND ABAONDON WATER MAIN

The existing water lines to be taken out of service are marked on the Drawings. These lines are to remain in service until the new lines are properly installed and tested, and water services have been connected. Approval from the City of Pendleton shall be obtained before any line is abandoned.

Unless called for otherwise, the abandoned lines will remain in the ground. The ends of all pipes which are abandoned shall be plugged with concrete or other methods approved by the City of Pendleton. **This item shall include, but not limited to, all labor, equipment, and tools necessary for a complete and approved job.**

18. INCIDENTAL ITEMS

All materials and work shown on the plans or necessary to complete the job and receive approval of the project, which are not identified as a separate pay item on the Proposal, shall not be measured for payment separately but shall be considered as subsidiary obligations of the Contractor.

19. CONTRACT COMPLETION TIME AND LIQUIDATED DAMAGES

Contractor shall furnish in writing a work schedule for the Project. Project schedule shall be updated and resubmitted every two (2) weeks.

The project must be completed prior to June 30, 2023. Liquidated damages shall be computed at the rate of one percent (1%) per calendar day of the total price of contract work not yet completed, or \$500.00 per calendar day, whichever is greater, for work not completed by June 30, 2023. Sundays and legal holidays shall be excluded in determining days of default.

Contractor to note that if the water line is installed after November 1, 2022, then the Contractor may temporarily patch with cold mix or Control Density Fill (CDF) all travel ways at no additional cost to the Contract. The Contractor will be required to maintain the temporary patch until a final patch with hot mix asphalt can be installed. The final patch shall be installed by June 30, 2023 in order to avoid assessment of liquidated damages.

Contractor to note that if there are delays with water parts delivery that would cause the Contractor to miss the Contract Deadline, then the Contractor will need to provide proof from their Supplier regarding the delayed delivery, and the City will consider giving a contract timeline extension. If a contract timeline extension is granted, then the Contractor must complete the Project no later than forty-five (45) days after the final delivery of the parts.

20. WORKING HOURS, RESTRICTIONS

Normal working hours are Monday through Friday - 7:00 am to 5:00 pm. Work may extend beyond this time period with prior written permission from the City. The Contractor shall notify the City forty-eight (48) hours in advance if work will be performed on Saturday, Sunday or Holidays or other than normal working hours.

Per Ordinance No. 2287, no work that produces dust or flying debris shall be performed or equipment utilized that produces noise of sufficient volume to disturb the sleep or repose of occupants of neighboring property between the hours of 6:00 pm and 7:00 am without expressed written permission from the City.

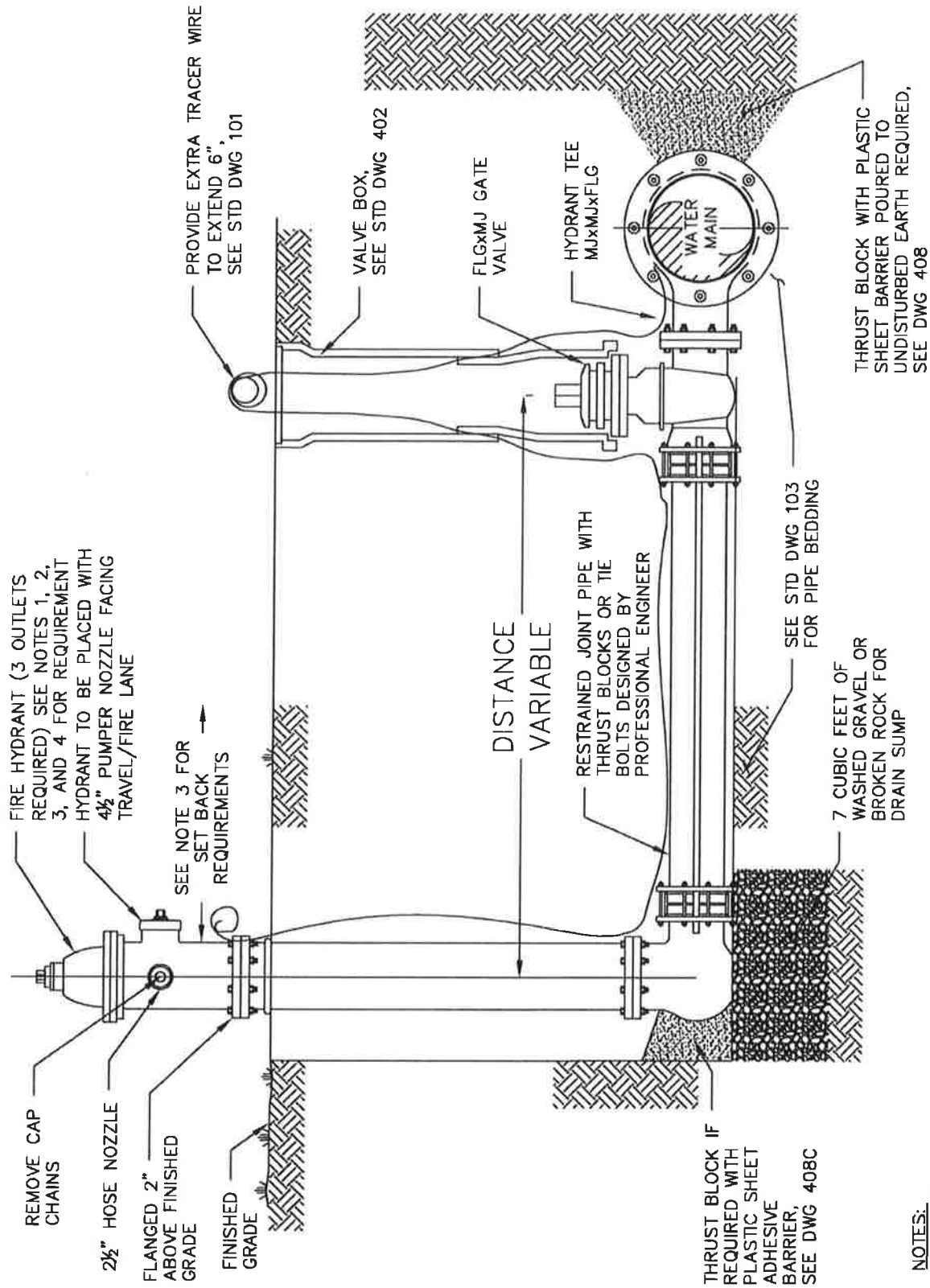

- NOTES:**
1. 5/4" COMPRESSION TYPE HYDRANTS, TRAFFIC MODEL (BREAK OFF FLANGE).
 2. 4' BURY, 6" MJ SHOE, TWO 2 1/2" NST DISCHARGES, ONE 4 1/2" PUMPER NOZZLE, OPEN LEFT.
 3. FIRE HYDRANT TO BE LOCATED ON PUBLIC RIGHT-OF-WAY 1' BACK OF SIDEWALK TYPICAL.
 4. THE CITY WILL ACCEPT ONLY THE FOLLOWING BRAND NAME HYDRANTS: MUELLER CENTURION NO. 200, CLOW MEDALLION, WATEROUS NO. WB-67-250, OR KENNEDY NO K-81A.



ENGINEERING DEPARTMENT
 500 S.W. DORION AVENUE PENDLETON, OREGON 97801
 VOICE: (541) 966-0203
 FAX: (541) 966-0251

APPROVED BY

 FEBRUARY 2019
 APPROVAL DATE
 REVISED DATE

HYDRANT ASSEMBLY

NO SCALE
 DWG NO.
 400

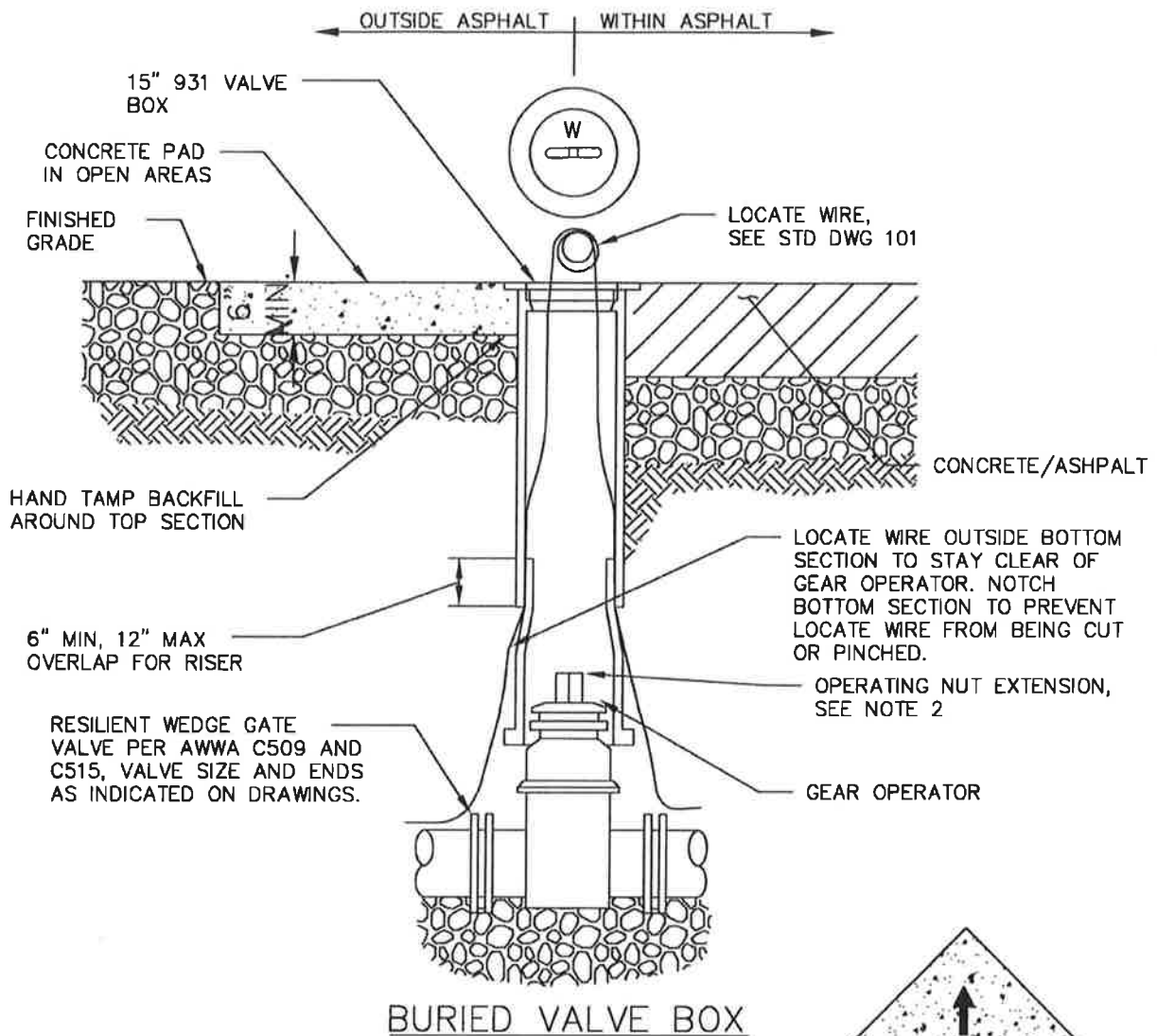

BURIED VALVE BOX

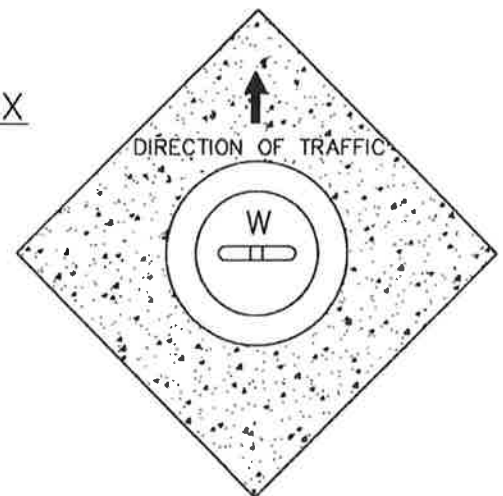

CONCRETE/ASPHALT PAD

NOTES:

1. VALVE BOX NOT TO REST ON OPERATING ASSEMBLY.
2. OPERATING NUT EXTENSION REQUIRED WHEN VALVE NUT IS DEEPER THAN 4' FROM FINISHED GRADE. SEE STD DWG 403.
3. CENTER VALVE BOX ON AXIS OF OPERATING NUT.
5. VALVE BOX PAD USED IN ROADWAY CAN BE 24" ROUND OR SQUARE, MADE OF CONCRETE 6" THICK OR OF ASPHALT TO MATCH EXISTING THICKNESS, MIN 4".
6. ORIENT GEAR OPERATOR TO CENTERLINE SIDE IN ROADWAYS.



ENGINEERING
DEPARTMENT
500 S.W. DORION
AVENUE PENDLETON,
OREGON 97801
VOICE: (541) 966-0203
FAX: (541) 966-0251

APPROVED BY

[Signature]

FEBRUARY 2019

APPROVAL DATE

REVISED DATE

**BURIED VALVE
AND BOX**

NO SCALE

DWG NO.

402

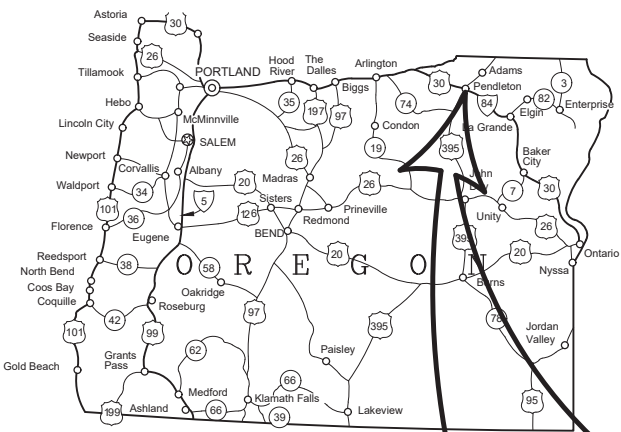

CITY OF PENDLETON, OREGON

SE 3RD STREET WATER MAIN REPLACEMENT 2022



CITY COUNCIL

JOHN TURNER, Mayor
 KEVIN MARTIN
 CAROLE L. INNES
 SALLY BRANDSEN
 MCKENNON MCDONALD
 LINDA K. NEUMAN
 DALE PRIMMER
 JAKE CAMBIER
 STEVE CAMPBELL

CITY OFFICIALS

ROBB CORBETT, City Manager
 BOB PATTERSON, Public Works Director
 TIM SIMONS, City Engineer

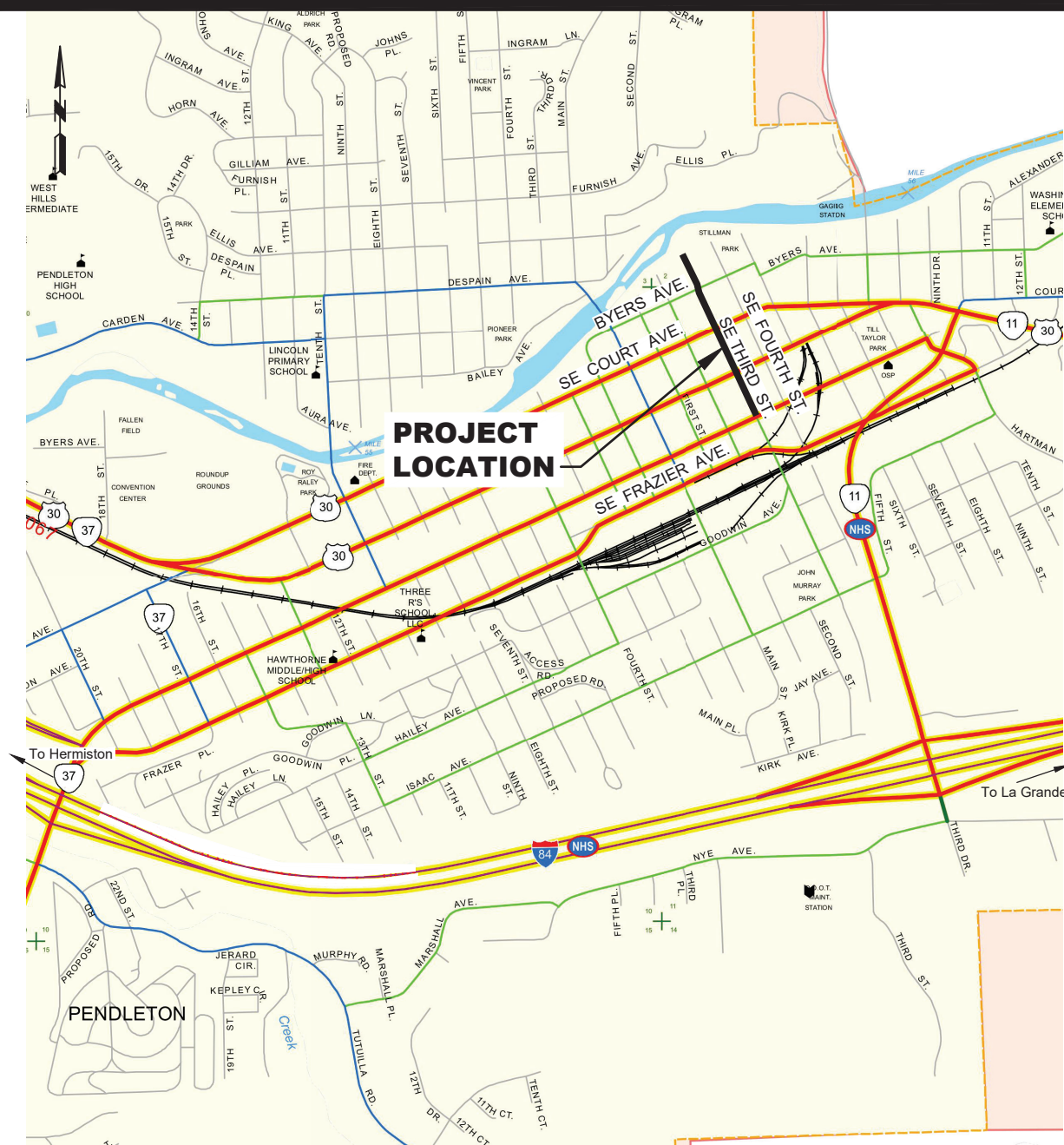

VICINITY MAP
N.T.S.

INDEX

- G-001 COVER
- G-002 GENERAL NOTES AND ABBREVIATIONS
- G-003 LEGEND
- G-004 TEMPORARY EROSION AND SEDIMENT CONTROL PLAN
- G-005 TRAFFIC CONTROL PLAN I
- G-006 TRAFFIC CONTROL PLAN II
- G-007 WATER SERVICE TABLE
- G-008 PLAN SHEET INDEX

UTILITIES

- U-101 PLAN AND PROFILE STA. A1+00 TO STA. A4+70
- U-102 PLAN AND PROFILE STA. A4+70 TO STA. A8+40
- U-103 PLAN AND PROFILE STA. A8+40 TO STA. A12+40
- U-104 PLAN AND PROFILE STA. 12+40 TO STA. A16+50
- U-501 DETAILS I
- U-502 DETAILS II



RENEWS 06-30-24
FINAL ELECTRONIC DOCUMENTS AVAILABLE UPON REQUEST



engineering • surveying • natural resources
 214 E. Birch Street - Walla Walla, WA 99362 Ph: (509)929-9260 Fax: (509)929-8102
 LA GRANDE, OR WALLA WALLA, WA REDMOND, OR HERMISTON, OR
 COPYRIGHT 2022 BY ANDERSON PERRY & ASSOCIATES, INC.

GENERAL CONSTRUCTION NOTES

1. THESE PLANS, SPECIFICATIONS, AND REFERENCED DOCUMENTS SHALL BE USED TO CONSTRUCT THE IMPROVEMENTS SHOWN. REFERENCED DOCUMENTS INCLUDE THE OREGON STANDARD SPECIFICATIONS FOR CONSTRUCTION (CURRENT EDITION), OREGON STANDARD DRAWINGS, CITY OF PENDLETON STANDARD PLANS, AND THE MANUAL ON UNIFORM TRAFFIC CONTROL DEVICES (MUTCD).
2. ALL EXISTING UTILITIES SHOWN ON THE PLANS ARE SHOWN WITH AS MUCH ACCURACY AS POSSIBLE, BASED ON AVAILABLE INFORMATION. SOME DISCREPANCIES AND OMISSIONS IN LOCATION, TYPE, AND SIZE SHOULD BE EXPECTED TO OCCUR. THE CONTRACTOR SHALL BE RESPONSIBLE FOR LOCATING AND PROTECTING ALL EXISTING UTILITIES IN AND AROUND THE WORK AREAS. BOTH PRIVATE AND PUBLIC POWER, WATER, IRRIGATION, TELEPHONE, GAS, CABLE, AND WASTEWATER SHALL BE INCLUDED. ANY DISCREPANCIES BETWEEN THE DESIGN SHEETS AND EXISTING CONDITIONS SHALL BE REPORTED TO THE ENGINEER.
3. EXISTING GAS LINES EXIST THROUGHOUT THE PROJECT AREA. IT IS ANTICIPATED THAT EXISTING AND NEW UTILITIES WILL RUN OVER AND UNDER EXISTING GAS LINES. BLIND BORING FOR WATER SERVICE INSTALLATION PAST THE GAS LINE WILL NOT BE ALLOWED. PIPE BURSTING FOR SEWER SERVICE INSTALLATION PAST THE GAS LINE WILL ONLY BE ALLOWED IF THE GAS LINE IS FULLY EXPOSED AT THE CROSSING LOCATION.
4. UNLESS OTHERWISE APPROVED BY THE CITY, THE CONTRACTOR SHALL PROVIDE CONTINUOUS ACCESS FOR EMERGENCY VEHICLES, LOCAL BUSINESSES, RESIDENCES, AND THEIR RESPECTIVE DRIVEWAYS. ACCESS SHALL ALSO BE PROVIDED FOR MAIL DELIVERY, SANITATION, AND OTHER MUNICIPAL/PRIVATE UTILITY PROVIDERS.
5. ALL CUTS IN EXISTING PAVEMENT SURFACES SHALL BE SAW CUT OR MADE WITH AN APPROPRIATE ZIPPER. THE DISTURBED AREAS SHALL BE PATCHED AS REQUIRED BY THE PLANS, SPECIFICATIONS, AND DETAILS.
6. ALL PIPES SHALL BE BEDDED WITH BEDDING BACKFILLED WITH CLASS B MATERIAL PER OREGON STD. SPEC. 00405.14 AS REQUIRED BY THE PLANS, SPECIFICATIONS, AND DETAILS.
7. THROUGHOUT THE PROJECT AREA, MAILBOXES, TRASH RECEPTACLES, FENCES, SIGNS, BIKE RACKS, UTILITIES, ETC. EXIST NEAR THE CURB LINE THAT MAY BE IMPACTED BY CONSTRUCTION. THE CONTRACTOR SHALL PROTECT, TEMPORARILY RELOCATE, AND REINSTALL THESE FACILITIES WHERE IMPACTED BY CONSTRUCTION. THIS SHALL BE INCIDENTAL TO THE WORK BEING COMPLETED. THE CONTRACTOR IS ADVISED THAT THE LOCATION OF FENCES, MAIL AND PAPER BOXES, TREES, LANDSCAPING, AND OTHER OBJECTS, IF SHOWN IN THE PLANS, IS PROVIDED SOLELY TO PROVIDE WARNING OF THE PROBABLE LOCATION OF SAID OBJECTS AND MAY NOT BE PRECISE OR COMPLETE. THE CONTRACTOR SHALL SATISFY THEMSELVES AS TO THE EXACT LOCATIONS BEFORE PROCEEDING WITH WORK.
8. THE CONTRACTOR SHALL KEEP THE SITE IN A NEAT AND ORDERLY CONDITION. ALL TRASH GENERATED BY THE CONTRACTOR'S OPERATIONS SHALL BE PICKED UP AT THE END OF EACH DAY. EQUIPMENT, VEHICLES AND MATERIALS SHALL BE STAGED EITHER OFFSITE OR ALONG CLOSED PORTIONS OF POPLAR ST/ALDER ST AND OFF SIDE STREETS.
9. PROTECT AND AVOID DAMAGE TO ALL PROPERTY OUTSIDE THE PUBLIC RIGHT-OF-WAY INCLUDING STRUCTURES, RETAINING WALLS, TREES, IRRIGATION SYSTEMS, WALKWAYS, AND LANDSCAPES.
10. EXISTING WATER SERVICES AND MAINS SHALL BE LEFT IN SERVICE UNTIL THE NEW WATER MAIN IS TESTED PER THE CITY STANDARD PLANS AND ACCEPTED BY THE CITY OF PENDLETON. COORDINATE WITH THE CITY TO PERFORM ALL WATER SERVICE SHUTDOWNS AND PROVIDE AFFECTED RESIDENTS NOTICE PRIOR TO SHUTDOWN IN ACCORDANCE WITH CITY OF PENDLETON STANDARD PLANS.
11. SALVAGEABLE MATERIALS SHALL BE TAKEN BY THE CONTRACTOR TO THE CITY OF PENDLETON PUBLIC WORKS SHOP 1501 SE BYERS AVENUE AND SHALL REMAIN THE CITY'S PROPERTY, THESE SHALL INCLUDE HYDRANTS, MANHOLE COVERS, CATCH BASINS GRATES, WATER METERS, SIGNS, OR OTHER MATERIALS DIRECTED BY THE CITY.

ABBREVIATIONS

| | | | |
|------|-------------------------------|-------|---|
| ACP | ASPHALT CONCRETE PAVEMENT | MIN | MINIMUM |
| BOC | BACK OF CURB | MJ | MECHANICAL JOINT |
| BOP | BEGINNING OF PAVING | MUTCD | MANUAL ON UNIFORM TRAFFIC CONTROL DEVICES |
| CB | CATCH BASIN | ODOT | OREGON STATE DEPARTMENT OF TRANSPORTATION |
| CL | CENTERLINE | PC | POINT OF CURVE |
| CSBC | CRUSHED SURFACING BASE COURSE | PL | PROPERTY LINE |
| CSTC | CRUSHED SURFACING TOP COURSE | PT | POINT OF TANGENT |
| DI | DUCTILE IRON PIPE | PUE | PUBLIC UTILITY EASEMENT |
| DOE | DEPARTMENT OF ECOLOGY | PVC | POLYVINYL CHLORIDE PIPE |
| ELEV | ELEVATION | PVI | POINT OF VERTICAL INTERSECTION |
| EOP | END OF PAVING | R/W | RIGHT-OF-WAY |
| EVCE | END VERTICAL CURVE ELEVATION | REQ'D | REQUIRED |
| EXTG | EXISTING | RT | RIGHT |
| FG | FINISH GRADE | SD | STORM DRAIN |
| FL | FLOW LINE | SDMH | STORM DRAIN MANHOLE |
| FLG | FLANGE | SS | SANITARY SEWER |
| FOC | FACE OF CURB | SSMH | SANITARY SEWER MANHOLE |
| GB | GRADE BREAK | STA | STATION |
| HMAC | HOT MIX ASPHALT CONCRETE | STD | STANDARD |
| HPT | HIGH POINT | TBC | TOP BACK OF CURB |
| IE | INVERT ELEVATION | TBDC | TOP BACK OF DEPRESSED CURB |
| JUT | JOINT UTILITY TRENCH | TC | TOP OF CURB |
| LP | LOW POINT | TP | TOP OF PAVEMENT |
| LT | LEFT | TYP | TYPICAL |
| MAX | MAXIMUM | VC | VERTICAL CURVE |
| ME | MATCH EXISTING | WM | WATER MAIN |



| | | | | | | |
|-------------|----------------|------|---|-----------------|------|------|
| REVISION | BY | DATE | JOB NUMBER | 77-58 | DATE | 2022 |
| DESIGNED BY | B. VIXIE | | ACAD FILE: | 77-58-G-002.dwg | | |
| DRAWN BY | L. WILLHITE | | COPYRIGHT 2022 BY ANDERSON PERRY & ASSOC., INC. | | | |
| REVIEWED BY | A. SCHMIDTGALL | | | | | |



CITY OF PENDLETON, OREGON
SE 3RD STREET WATER MAIN REPLACEMENT

GENERAL NOTES AND ABBREVIATIONS

SHEET

G-002

PLAN LEGEND

SITE SURVEY

| | EXISTING | PROPOSED |
|--------------------|-----------------|---------------|
| WATER | | |
| WATER LINE | ---W---W---W--- | 6"W |
| ABANDON WATER LINE | | ~W~W~W~W~W~W~ |
| VALVE | ⊠ | ⊠ |
| CAP | ⌈ | ⌈ |
| COUPLING | ⊞ | ⊞ |
| REDUCER | ▷ | ▷ |
| FIRE HYDRANT | ⊕ | ⊕ |
| WATER METER | ⊞ | ⊞ |
| AIR RELEASE VALVE | ↑ | ↑ |
| HOSE BIBB | ⊠ | ⊠ |

| | EXISTING | PROPOSED |
|---------------------------------------|---------------|---------------|
| INDEX CONTOUR | -----750----- | -----750----- |
| INTERMEDIATE CONTOUR | -----749----- | -----749----- |
| PROPERTY LINE/RIGHT-OF-WAY CENTERLINE | ----- | ----- |
| EASEMENT | ----- | ----- |
| SECTION LINE | ----- | ----- |
| MONUMENT | △ | △ |
| CONTROL POINT | ⊙ | ⊙ |
| TEST PIT | ⊙ | ⊙ |

| | EXISTING | PROPOSED |
|---------------------------------------|----------|----------|
| STREET AND CURB | | |
| CURB AND SIDEWALK | | |
| DRIVEWAY/ACCESS RAMP W/ WARNING STRIP | | |
| PAVED STREET | 1ST ST. | 1ST ST. |
| GRAVEL DRIVEWAY/STREET | | |

| | EXISTING | PROPOSED |
|--------------------------|--------------------|----------|
| SEWER/STORM DRAIN | | |
| SEWER LINE | ---SS---SS---SS--- | 6"SS |
| STORM DRAIN | ---SD---SD---SD--- | 6"SD |
| CULVERT | ⌈ | ⌈ |
| GRAVITY SEWER MANHOLE | ⊙ | ⊙ |
| STORM DRAIN MANHOLE | ⊙ | ⊙ |
| CATCH BASIN | □ | □ |
| CLEANOUT | ◇ | ◇ |
| AIR RELEASE VALVE | ↑ | ↑ |

| | EXISTING | PROPOSED |
|-----------------|----------|----------|
| GENERAL | | |
| FENCE LINE/GATE | X | X |
| CHAINLINK FENCE | ⊞ | ⊞ |
| WOOD FENCE | ⊞ | ⊞ |
| RAILROAD | ⊞ | ⊞ |
| MAILBOX | ⊞ | ⊞ |
| SIGN | ⊞ | ⊞ |

| | EXISTING | PROPOSED |
|---------------------------------|----------|----------|
| TRAFFIC CONTROL | | |
| TYPICAL TRAFFIC CONTROL ARROWS | | |
| TYPICAL TRAFFIC CONTROL SYMBOLS | | |
| TYPICAL TRAFFIC DIVIDER LINES | | |
| FOG LINE | | |

MISCELLANEOUS UTILITIES

| | EXISTING | PROPOSED |
|--------------------|--------------------|--------------------|
| OVERHEAD POWER | ---OHP---OHP--- | ---OHP---OHP--- |
| BURIED TELEPHONE | ---T---T---T--- | ---T---T---T--- |
| OVERHEAD TELEPHONE | ---OHT---OHT--- | ---OHT---OHT--- |
| GAS SERVICE | ---G---G---G--- | ---G---G---G--- |
| FIBER OPTIC | ---FO---FO---FO--- | ---FO---FO---FO--- |
| IRRIGATION | ---IRR--- | ---IRR--- |
| IRRIGATION VALVE | ⊠ | ⊠ |
| UNKNOWN UTILITY | ---?---?---?--- | ---?---?---?--- |
| UTILITY POLE | ⊙ | ⊙ |
| GUY WIRE | ⊞ | ⊞ |
| TELEPHONE RISER | ◇ | ◇ |
| STREET LIGHT | ⊙ | ⊙ |

| | | |
|-----------------|--|--|
| TREE, CONIFER | | |
| TREE, DECIDUOUS | | |
| SHRUB/BRUSH | | |
| BUILDING | | |

DRAFTING

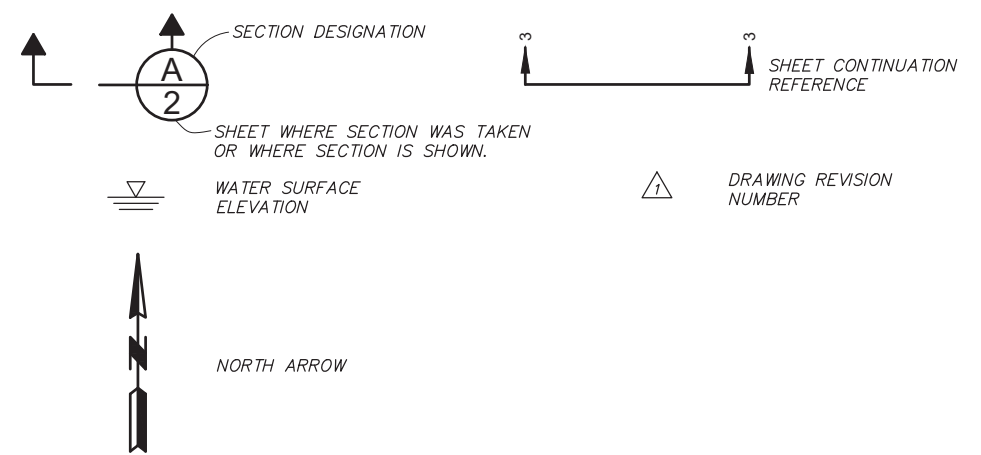

VERTICAL DATUM
ELEVATIONS SHOWN ARE A REPRESENTATION OF NGVD29 WITH REFERENCE TO THE CITY OF PENDLETON'S VERTICAL CONTROL NETWORK.

BASIS OF BEARING/HORIZONTAL DATUM
THE COORDINATES OF ALL POINTS ARE BASED ON THE CITY OF PENDLETON'S HORIZONTAL CONTROL NETWORK. A LOCAL DATUM PLANE BASED ON GROUND MEASUREMENTS.

| APA CONTROL POINTS | | | | |
|--------------------|----------|----------|-----------|------------------|
| POINT # | NORTHING | EASTING | ELEVATION | FULL DESCRIPTION |
| 2 | 51611.65 | 48471.48 | 1072.01 | APA-PEN-CP2 |
| 6 | 52254.43 | 48195.56 | 1071.35 | APA-PEN-CP6 |
| 9 | 50998.93 | 48688.69 | 1073.63 | APA-PEN-CP9 |

NOTE
IT SHALL BE THE CONTRACTOR'S RESPONSIBILITY TO PROTECT AND/OR REFERENCE CONTROL POINTS WITHIN AREAS TO BE DEMOLISHED.

REGISTERED PROFESSIONAL ENGINEER
77752PE
Digitally Signed
JAN. 8, 2019
ADAM GARRETT SCHMIDTGALL
7/5/22
RENEWS 06-30-24
FINAL ELECTRONIC DOCUMENTS AVAILABLE UPON REQUEST

| REVISION | BY | DATE | JOB NUMBER | DATE |
|----------------------------|----|------|---|------|
| DESIGNED BY B. VIXIE | | | 77-58 | 2022 |
| DRAWN BY L. WILLHITE | | | ACAD FILE: 77-58-G-003.dwg | |
| REVIEWED BY A. SCHMIDTGALL | | | COPYRIGHT 2022 BY ANDERSON PERRY & ASSOC., INC. | |

anderson perry & associates, inc.
engineering • surveying • natural resources

CITY OF PENDLETON, OREGON
SE 3RD STREET WATER MAIN REPLACEMENT

SHEET
G-003

LEGEND



CONSTRUCTION NOTES

- ① INSTALL STORM DRAIN INLET PROTECTION ON EXISTING CATCH BASIN. SEE OREGON STANDARD DRAWING RD1010, TYPE 3. INSTALL PRIOR TO PLANING OR SOIL DISTURBANCE.
- ② INLET PROTECTION AT THE INTERSECTION OF SE BYERS AVENUE AND SE 3RD STREET TO BE PROVIDED BY OTHERS

EROSION CONTROL NOTES

1. THE CONTRACTOR SHALL BE RESPONSIBLE FOR IMPLEMENTING AND MAINTAINING ALL BEST MANAGEMENT PRACTICES (BMP'S) AS APPLICABLE TO PREVENT DEBRIS, OILS, SEDIMENTS, ETC. FROM ENTERING SURFACE AND/OR GROUNDWATER.
2. INLET PROTECTION SHALL BE PROVIDED FOR EXISTING INLETS TO BE PROTECTED THROUGH THE DURATION OF THE PROJECT. THE CONTRACTOR SHALL INSPECT ALL INLET PROTECTION AFTER EACH STORM EVENT AND REMOVE ANY SEDIMENTATION TO ENSURE THAT NO SEDIMENTS ARE ENTERING THE CATCH BASIN. REMOVE ALL INLET PROTECTION UPON PROJECT COMPLETION.
3. DUST CONTROL SHALL BE ONGOING THROUGH THE DURATION OF THE PROJECT UNTIL THE SITE HAS BEEN PAVED OR STABILIZED WITH PERMANENT VEGETATION. THE CONTRACTOR SHALL TAKE APPROPRIATE ACTION TO CONTROL DUST CAUSED BY THEIR OPERATIONS. THIS SHALL INCLUDE, BUT NOT LIMITED TO, WATERING OF EXPOSED AREAS.
4. PROTECTION OF THE ENVIRONMENT: NO CONSTRUCTION-RELATED ACTIVITY SHALL CONTRIBUTE TO THE DEGRADATION OF THE ENVIRONMENT, ALLOW MATERIAL TO ENTER SURFACE OR GROUNDWATERS, OR ALLOW PARTICULATE EMISSIONS TO THE ATMOSPHERE WHICH EXCEED STATE OR FEDERAL STANDARDS. ANY ACTIONS THAT POTENTIALLY ALLOW A DISCHARGE TO STATE WATERS MUST HAVE PRIOR APPROVAL OF THE OREGON STATE DEPARTMENT OF ENVIRONMENTAL QUALITY.
5. CONSTRUCTION SHALL BE STAGED SO THAT EXPOSED SOILS ARE NOT SUBJECT TO VEHICLE TRAFFIC.
6. EQUIPMENT AND VEHICLES SHALL BE CLEANED OFF SITE AT A LOCATION WHERE ANY POLLUTANTS REMOVED WILL NOT ENTER STORMWATER.
7. INSTALL EROSION CONTROL MEASURES PRIOR TO PERFORMING ANY OTHER ON-SITE WORK.
8. THE IMPLEMENTATION OF THE EROSION CONTROL PLANS AND THE CONSTRUCTION, MAINTENANCE, REPLACEMENT, AND UPGRADING OF THESE FACILITIES ARE THE RESPONSIBILITY OF THE CONTRACTOR UNTIL ALL CONSTRUCTION IS COMPLETED AND APPROVED.
9. THE EROSION CONTROL FACILITIES SHOWN ON THIS PLAN ARE THE MINIMUM REQUIREMENTS FOR ANTICIPATED SITE CONDITIONS. DURING THE CONSTRUCTION PERIOD, THESE FACILITIES SHALL BE UPGRADED FOR UNEXPECTED STORM EVENTS AND TO ENSURE THAT SEDIMENT AND SEDIMENT-LADEN WATER DO NOT LEAVE THE SITE.
10. CONCRETE WASHOUT SHALL TAKE PLACE OFF SITE.

LEGEND

-  PROJECT AREA
-  STABILIZED CONSTRUCTION ENTRANCE
-  EXISTING CATCH BASIN

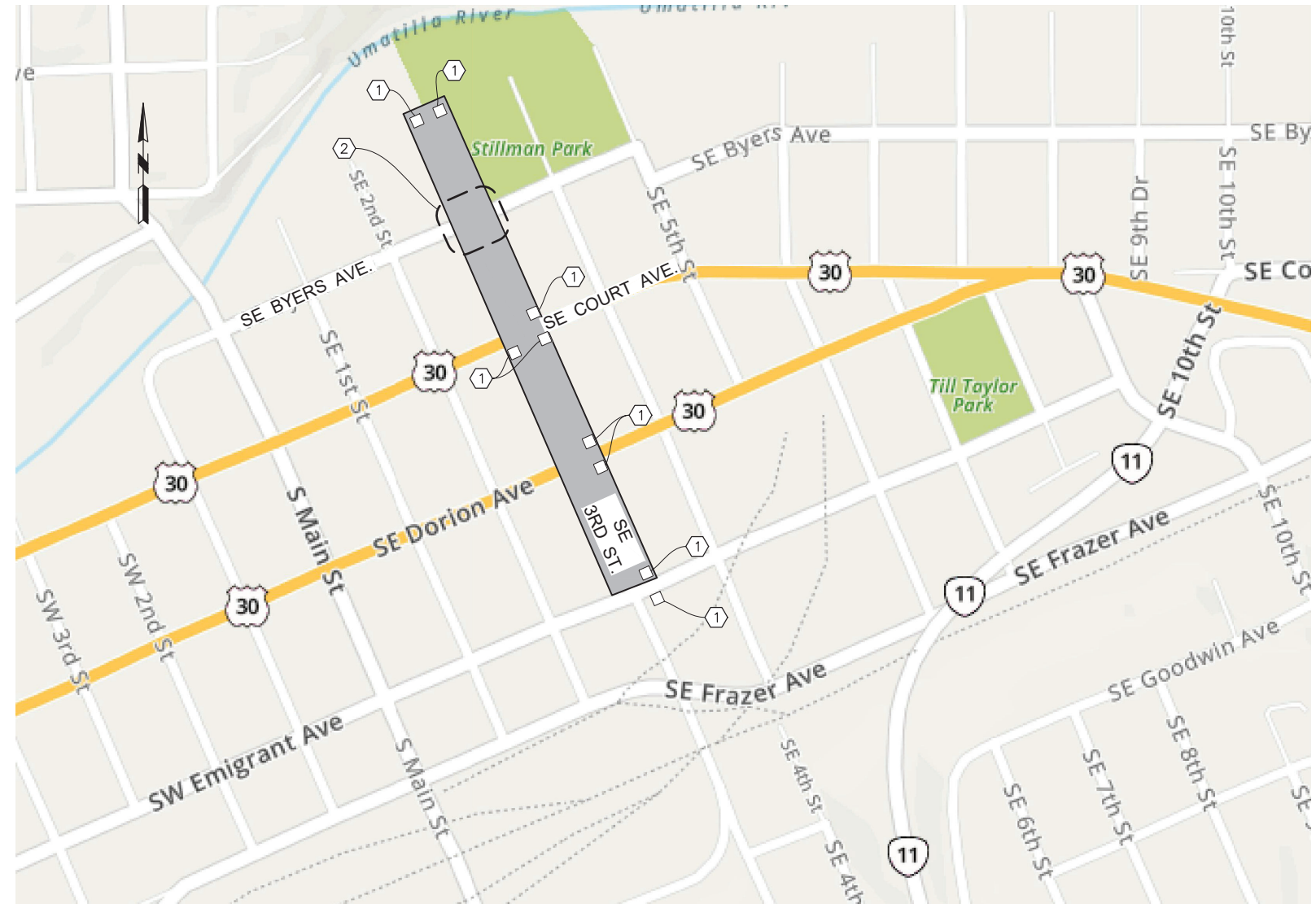

| | | | | | | |
|-------------|----------------|------|---|-----------------|------|------|
| REVISION | BY | DATE | JOB NUMBER | 77-58 | DATE | 2022 |
| DESIGNED BY | B. VIXIE | | ACAD FILE: | 77-58-G-004.dwg | | |
| DRAWN BY | L. WILLHITE | | COPYRIGHT 2022 BY ANDERSON PERRY & ASSOC., INC. | | | |
| REVIEWED BY | A. SCHMIDTGALL | | | | | |



CITY OF PENDLETON, OREGON
SE 3RD STREET WATER MAIN REPLACEMENT

TEMPORARY EROSION AND SEDIMENT CONTROL PLAN

SHEET

G-004

GENERAL TRAFFIC CONTROL NOTES

1. THE CONTRACTOR SHALL BE RESPONSIBLE FOR ALL VEHICULAR AND PEDESTRIAN TRAFFIC CONTROL. ODOT STANDARD PLANS AND THE TRAFFIC CONTROL PLANS INCLUDED IN THESE CONTRACT DOCUMENTS SHALL BE USED AS A GUIDE FOR TRAFFIC CONTROL. THE CONTRACTOR SHALL SUBMIT DETAILED TRAFFIC CONTROL PLANS AND OBTAIN APPROVAL FROM THE CITY PRIOR TO THE START OF CONSTRUCTION. ALL SIGNING SHALL COMPLY WITH THE MUTCD AND ALL TRAFFIC OPERATIONS MUST BE ACCEPTABLE TO THE CITY OF PENDLETON.
2. APPROPRIATE METHODS OF PEDESTRIAN AND VEHICULAR TRAFFIC CONTROL, INCLUDING FLAGGERS, SHALL BE USED BY THE CONTRACTOR TO THE EXTENT DEEMED NECESSARY BY THE CONTRACTOR OR THE ENGINEER TO PROTECT WORKERS OR THIRD PARTIES. THE PLAN SHOWN IN THESE CONTRACT DOCUMENTS IS THE MINIMUM REQUIRED AND SHALL BE SUPPLEMENTED WITH ADDITIONAL TRAFFIC CONTROL MEASURES AS REQUIRED DURING THE COURSE OF WORK.
3. ALL TRAFFIC CONTROL DEVICES SHALL BE IN ACCORDANCE WITH THE LATEST EDITION OF THE MUTCD.
4. ALL TRAFFIC CONTROL SIGNS AND DEVICES USED ON THIS PROJECT SHALL BE NEW OR LIKE NEW CONDITION.
5. TWO FLASHING WARNING LIGHTS SHALL BE USED TO MARK EACH BARRICADE AT NIGHT.
6. LOCATIONS OF ALL SIGNS SHALL BE AS APPROVED BY THE CITY OF PENDLETON.
7. REMOVE, COVER, OR RELOCATE SIGNS AS REQUIRED DURING VARIOUS CONSTRUCTION OPERATIONS.
8. EXCEPT WHEN APPROVED BY THE CITY, ACCESS SHALL BE PROVIDED AT ALL TIMES TO EMERGENCY VEHICLES, MAIL DELIVERY, SANITATION, PROPERTY OWNERS, AND BUSINESSES WITHIN PROJECT LIMITS.
9. THE CONTRACTOR SHALL BE RESPONSIBLE FOR MARKING AND MOVING ALL GARBAGE CANS ON GARBAGE COLLECTION DAY TO AN AREA ACCESSIBLE BY THE GARBAGE TRUCK.
10. PROPERTY OWNERS/TENANTS SHALL BE NOTIFIED AT LEAST 2 DAYS PRIOR TO DRIVEWAY CLOSURES.
11. UNLESS OTHERWISE APPROVED BY THE CITY, ROAD CLOSURES WILL ONLY BE ALLOWED DURING PIPE INSTALLATION AND FINAL PAVING. ROADS SHALL BE REOPENED TO LOCAL TRAFFIC AT THE END OF EACH DAY, WHEN CLOSURES ARE IMPLEMENTED.
12. "SIDEWALK CLOSED AHEAD" SIGNS SHALL BE PLACED ON TYPE II BARRICADES AHEAD OF ANY LOCATION WHERE AN EXISTING SIDEWALK OR ADA RAMP IS UNDER CONSTRUCTION.
13. PROVIDE LANE CLOSURES FOR WORK WITHIN INTERSECTIONS SEE SHEET G-006 FOR AN EXAMPLE OF A DOUBLE-LANE CLOSURE TRAFFIC CONTROL PLAN.
14. COURT AVENUE, DORION AVENUE, EMIGRANT AVENUE, AND FRAZER AVENUE SHALL NOT BE CLOSED AT ANY TIME.
15. CONTRACTOR SHALL HAVE BUSINESS ACCESS SIGNS (SIGNS 8, 9, AND 10 THIS SHEET. SIZE AT 36"x18"), AND BUSINESS SPECIFIC ACCESS BOARDS (DETAIL A, THIS SHEET), AVAILABLE AS REQUIRED FOR ADJACENT BUSINESSES.
16. LOCATE PEDESTRIAN DETOUR SIGNS AS NECESSARY AS CONSTRUCTION PROGRESSES. CONSTRUCTION SHALL BE PHASED TO MAINTAIN NORTH/SOUTH AND EAST/WEST PEDESTRIAN ACCESS AROUND THE PROJECT AT ALL TIMES. SIDEWALK CLOSED SIGNS ON TYPE II BARRICADES SHALL BE USED WHERE NEEDED.
17. WORK ON SE BYERS AVENUE AND SE 4TH STREET WILL BE COMPLETED UNDER A SEPARATE CONTRACT. CONTRACTOR SHALL BE REQUIRED TO COORDINATE WORK AND TRAFFIC CONTROL WITH THE BYERS AVENUE CONTRACTOR.

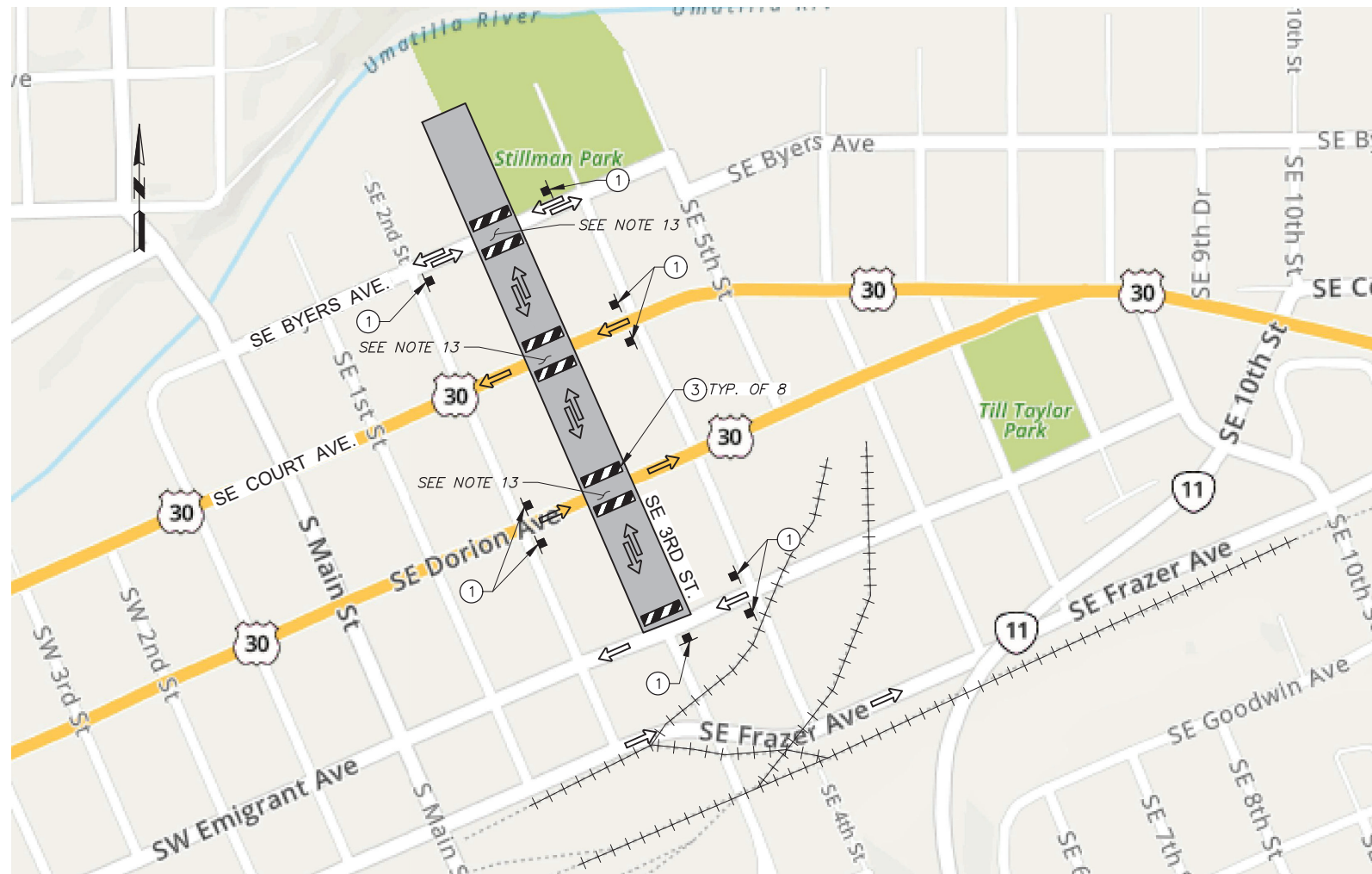

LEGEND

- WORK AREA
- TYPE III BARRICADE
- SIGN
- DIRECTION OF TRAFFIC



ACCESS BOARD NOTES

1. BOARD SHALL BE 24" WIDE x 48" TALL.
2. DIRECTION ARROW SHALL BE POSITIONED APPROPRIATELY TO DIRECT DRIVERS TO INDIVIDUALLY LISTED BUSINESSES.
3. ACCESS BOARD SIGNS SHALL BE 2-SIDED SANDWICH BOARDS, WITH INFORMATION LISTED ON EACH SIDE. SANDWICH BOARDS SHALL BE SECURED WITH SAND BAGS TO PREVENT OVERTURNING.
4. CONTRACTOR SHALL PROVIDE AND MAINTAIN APPROX TEN (10) BUSINESS SPECIFIC ACCESS SIGNS. EXACT LOCATIONS AND BUSINESS NAMES TO BE DETERMINED AS WORK PROGRESSES.

DETAIL A
BUSINESS SPECIFIC ACCESS BOARD
N.T.S.

| | | | | | | | | | | | |
|---|--|------------------|---|--|--|---|--|---|---|--|---|
| ① | | W20-3 36"x36" | ④ | | WB-1 36"x36" INSTALL WHERE 2' OR GREATER VERTICAL DROP EXISTS | ⑦ | | M4-9BR 30"x24" | ⑩ | | CUSTOM WHITE/BLUE 48"x30" OR 36"x18" |
| ② | | W20-1 36"x36" | ⑤ | | R9-9 24"x12" | ⑧ | | CUSTOM WHITE/BLUE 48"x30" OR 36"x18" | ⑨ | | CUSTOM WHITE/BLUE 48"x30" OR 36"x18" |
| ③ | | R11-4 48"x30" | ⑥ | | M4-9BL 30"x24" | | | | | | |

*SIGNAGE TO BE PLACED AS NEEDED FOR CONTRACTOR'S WORK SEQUENCE.

REGISTERED PROFESSIONAL
ENGINEER
77752PE
Digitally Signed
JAN. 8, 2019
ADAM GARRETT SCHMIDTGALL
7/5/22
RENEWS 06-30-24

| | | | |
|---|----------------|------------|-----------------|
| DESIGNED BY | B. VIXIE | DATE | 2022 |
| DRAWN BY | L. WILLHITE | JOB NUMBER | 77-58 |
| REVIEWED BY | A. SCHMIDTGALL | ACAD FILE: | 77-58-G-005.dwg |
| REVISION | | BY | |
| | | | |
| | | | |
| COPYRIGHT 2022 BY ANDERSON PERRY & ASSOC., INC. | | | |

ap
anderson
perry
& associates, inc.
engineering • surveying • natural resources

CITY OF PENDLETON, OREGON
SE 3RD STREET WATER MAIN REPLACEMENT

TRAFFIC CONTROL PLAN I

SHEET

G-005

LEGEND

- ➔ DIRECTION OF TRAFFIC
- ⊗ TRAFFIC SAFETY DRUM
- ▷ TEMPORARY SIGN LOCATION
- ▷▷ SEQUENTIAL ARROW SIGN
- ☒ TRANSPORTABLE ATTENUATOR
- PCMS PORTABLE CHANGEABLE MESSAGE SIGN. SEE DETAIL, THIS SHEET
- ⊗ TEMPORARY SIGN LOCATION (5' (FT) MOUNTING HEIGHT)

| PCMS | |
|----------------------|------------------------|
| 1 | 2 |
| 2 LANES CLOSED AHEAD | WATCH FOR SLOW TRAFFIC |
| 2.0 SEC | 2.0 SEC |

PORTABLE CHANGEABLE MESSAGE SIGN

N.T.S.

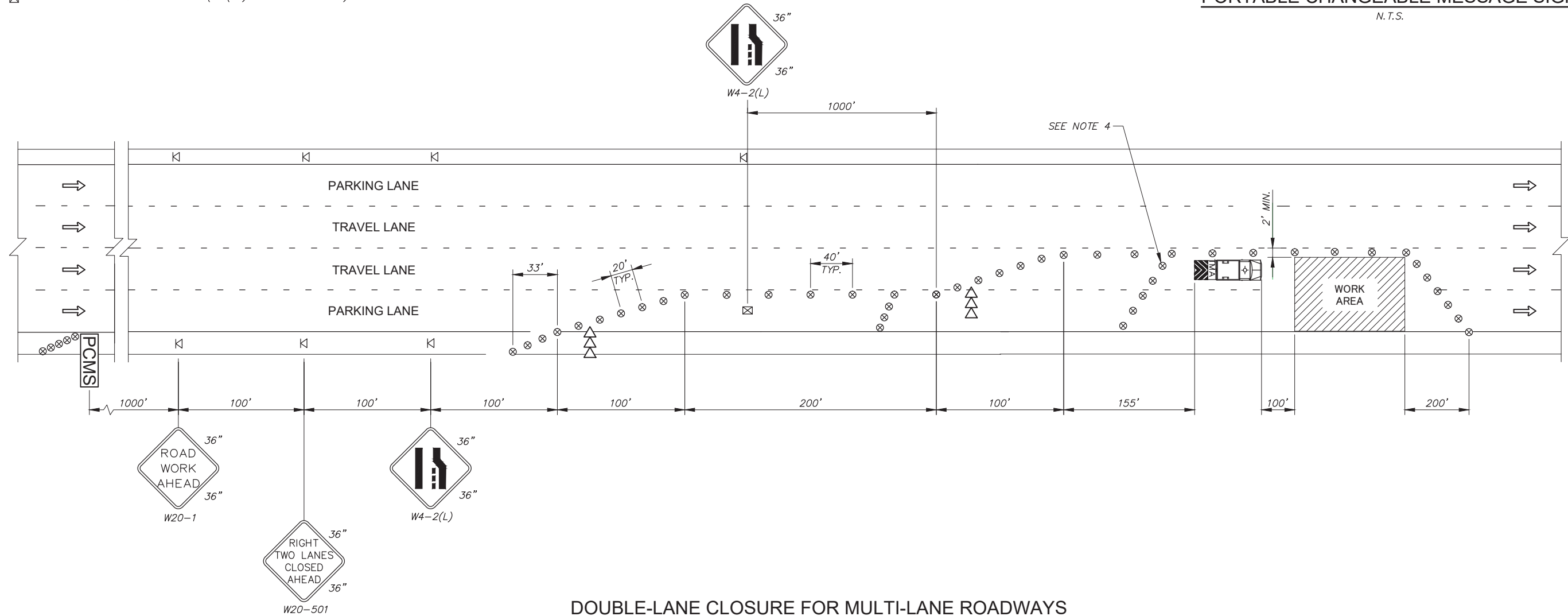

DOUBLE-LANE CLOSURE FOR MULTI-LANE ROADWAYS

N.T.S.

NOTES

1. MIRROR PLAN FOR WORK ON OPPOSITE SIDE OF INTERSECTION.
2. CONTRACTOR MUST KEEP ONE LANE OPEN. MAY USE PARKING LANE PROVIDED CONTRACTOR WORKS WITH OWNERS TO RELOCATE PARKED CARS.

REGISTERED PROFESSIONAL ENGINEER
77752PE
Digitally Signed
ADAM GARRETT SCHMIDTGALL
JAN. 8, 2019
7/5/22
RENEWS 06-30-24
FINAL ELECTRONIC DOCUMENTS AVAILABLE UPON REQUEST

| | | | | |
|----------------------------|----|------|---|-----------|
| REVISION | BY | DATE | JOB NUMBER 77-58 | DATE 2022 |
| DESIGNED BY B. VIXIE | | | ACAD FILE: 77-58-G-006.dwg | |
| DRAWN BY L. WILLHITE | | | COPYRIGHT 2022 BY ANDERSON PERRY & ASSOC., INC. | |
| REVIEWED BY A. SCHMIDTGALL | | | | |



CITY OF PENDLETON, OREGON
SE 3RD STREET WATER MAIN REPLACEMENT

TRAFFIC CONTROL PLAN II

SHEET

G-006

| WATER SERVICES | | | | | | | | | | |
|---------------------------|--------------------------------------|--------------------------------------|--------------|---------------------------|---------------------|-----------------------|---------------------------|------------------|----------------------|-----------------------|
| PROPERTY ADDRESS | APPROX STATION AT CONNECTION TO MAIN | ACTUAL STATION AT CONNECTION TO MAIN | RT/LT OFFSET | APPROX NEW SERVICE LENGTH | EXISTING METER SIZE | EXISTING SERVICE SIZE | EXISTING SERVICE MATERIAL | NEW SERVICE SIZE | NEW SERVICE MATERIAL | COMMENTS |
| 27 SE 3RD STREET | A2+06 | | RT | 27' | | | | 1" | | CITY TO INSTALL |
| 35 SE 3RD STREET | A2+78 | | RT | 27' | | | | 1" | | CITY TO INSTALL |
| 14 SE 3RD STREET | A3+26 | | LT | 22' | | 2" | COPPER | 2" | | CITY TO INSTALL |
| 43 SE 3RD STREET | A3+24 | | RT | 27' | | 1 1/2" | | 1 1/2" | | CITY TO INSTALL |
| 43 SE 3RD STREET | A3+31 | | RT | 14' | | 6" | DUCTILE IRON | 6" | DI | CONTRACTOR TO INSTALL |
| 101 SE 3RD STREET | A5+51 | | RT | 26 | | | | 1" | | CITY TO INSTALL |
| 124 AND 126 SE 3RD STREET | A6+07 | | LT | 18' | | 3/4" | | 1" | | CITY TO INSTALL |
| 335 SE COURT AVENUE | A6+98 | | LT | 18' | | 6" | DUCTILE IRON | 6" | DI | CONTRACTOR TO INSTALL |
| 302 SE COURT AVENUE | A8+89 | | LT | 27' | | | | 1" | | CITY TO INSTALL |
| 222 SE 3RD STREET | A9+99 | | LT | 39 | | | | 1" | | CITY TO INSTALL |
| 230 SE 3RD STREET | A9+35 | | RT | 5' | | 1" | | 1" | | CITY TO INSTALL |
| 240 SE 3RD STREET | A10+40 | | LT | 39' | | | | 1" | | CITY TO INSTALL |
| 241 SE 3RD STREET | A11+07 | | RT | 25 | | | | 1" | | CITY TO INSTALL |
| 247 SE 3RD STREET | A11+38 | | RT | 25' | | | | 1" | | CITY TO INSTALL |
| 329 SE 3RD STREET | A13+97 | | RT | 40 | | | | 1" | | CITY TO INSTALL |
| 335 SE 3RD STREET | A14+38 | | RT | 40' | | | | 1" | | CITY TO INSTALL |
| 334 SE 3RD STREET | A14+59 | | LT | 16' | | 3/4" | | 1" | | CITY TO INSTALL |
| 344 SE 3RD STREET | A14+90 | | LT | 16' | | 3/4" | | 1" | | CITY TO INSTALL |
| 356 SE 3RD STREET | A15+24 | | LT | 16' | | 3/4" | | 1" | | CITY TO INSTALL |
| 355 SE 3RD STREET | A15+34 | | RT | 40' | | | | 1" | | CITY TO INSTALL |
| 305 AND 360 SE 3RD STREET | A15+96 | | LT | 18' | | 3/4" | | 1" | | CITY TO INSTALL |

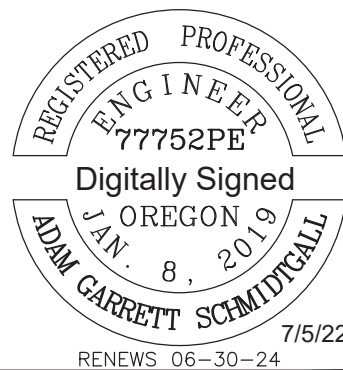

| | | |
|----------------------------|----|------|
| REVISION | BY | DATE |
| DESIGNED BY B. VIXIE | | |
| DRAWN BY L. WILLHITE | | |
| REVIEWED BY A. SCHMIDTGALL | | |

| | |
|---|-----------|
| JOB NUMBER 77-58 | DATE 2022 |
| ACAD FILE: 77-58-G-007.dwg | |
| COPYRIGHT 2022 BY ANDERSON PERRY & ASSOC., INC. | |



CITY OF PENDLETON, OREGON
SE 3RD STREET WATER MAIN REPLACEMENT

WATER SERVICE TABLE

SHEET

G-007

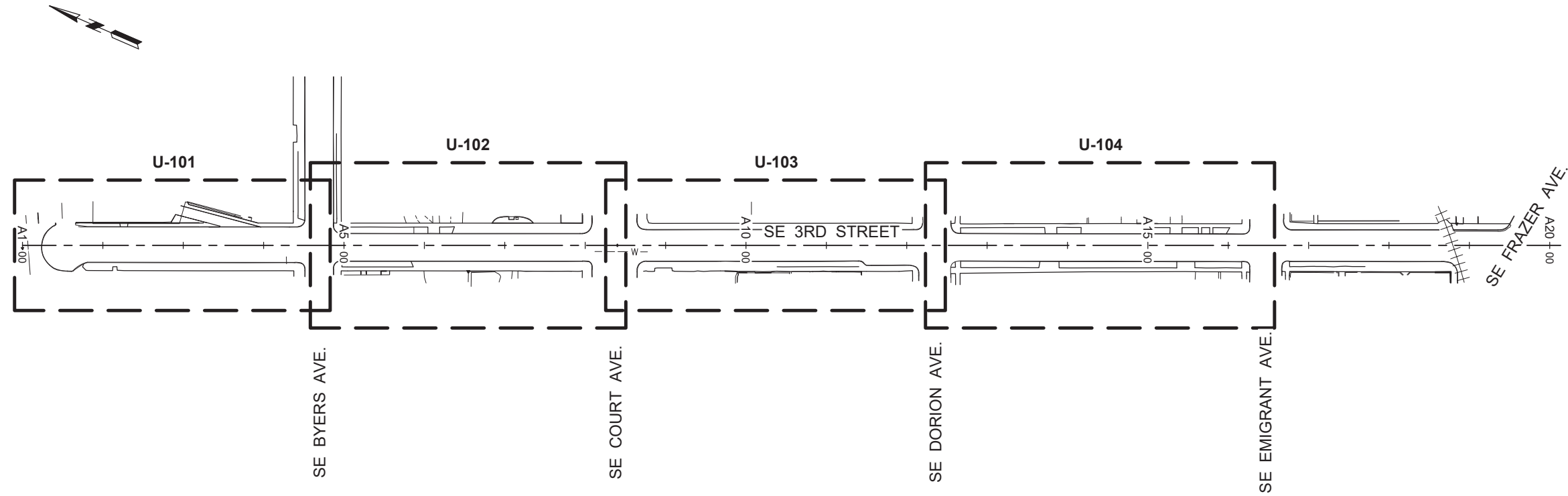

SHEET INDEX

REGISTERED PROFESSIONAL
ENGINEER
77752PE
Digitally Signed
JAN. 8, 2019
ADAM GARRETT SCHMIDTGALL
7/5/22
RENEWS 06-30-24
FINAL ELECTRONIC DOCUMENTS AVAILABLE UPON REQUEST

| REVISION | BY | DATE |
|----------|----|------|
| | | |
| | | |
| | | |

| | | |
|-----------------------------|---|------------|
| DESIGNED BY: B. VIXIE | JOB NUMBER: 77-58 | DATE: 2022 |
| DRAWN BY: L. WILLHITE | ACAD FILE: 77-58-G-008.dwg | |
| REVIEWED BY: A. SCHMIDTGALL | COPYRIGHT 2022 BY ANDERSON PERRY & ASSOC., INC. | |

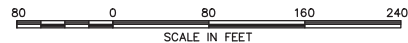

CITY OF PENDLETON, OREGON
SE 3RD STREET WATER MAIN REPLACEMENT

PLAN SHEET INDEX

SHEET
G-008

WATER WORK ITEMS

1. INSTALL WATER MAIN, SEE CITY STD. PLANS 101, 103, 402, 403, 407A-B, AND 408A-C.
2. EXISTING WATER MAIN AND SERVICES TO REMAIN IN OPERATION UNTIL THE NEW MAIN HAS BEEN FLUSHED, DISINFECTED, AND TESTED. THE CITY WATER CREW WILL INSTALL THE NEW WATER SERVICE AND APPURTENANCES TO THE PROPERTY LINE OR RECONNECT AS NECESSARY. THE CONTRACTOR SHALL BE RESPONSIBLE FOR ALL TRENCHING, BEDDING, BACK FILL, SURFACE RESTORATION, AND COMPACTION. SEE CITY STD. PLAN 409 FOR TYPICAL SERVICE LATERAL INSTALLATION.
3. PATCH CURB, GUTTER, AND SIDEWALK WITH NEW CONCRETE. CURB, GUTTER, AND SIDEWALK TO MATCH EXISTING.
4. PATCH CURB, GUTTER, AND SIDEWALK WITH ASPHALT. SEE DETAIL, SHEET U-502.
5. PATCH ASPHALT IN SE 3RD STREET WITH 2" ASPHALT AND 4" BASE ROCK. TEMPORARY PATCH PER CITY STD. PLAN 103. T-CUT NOT REQUIRED.
6. PATCH ASPHALT IN SE COURT AVE WITH 5" ASPHALT AND 12" BASE ROCK. SEE CITY STD. PLAN 103 AND 201.

NOTES

1. WATER MAINS SHALL BE INSTALLED WITH A MINIMUM OF 36 INCHES OF COVER. WATER MAINS SHALL BE DEEPER THAN 36 INCHES TO AVOID OTHER UTILITIES AND TO LINE UP WITH EXISTING WATER MAIN CONNECTIONS. REFER TO THE PROFILE FOR ADDITIONAL INFORMATION.
2. WHERE THE WATER MAIN CROSSES A NON-POTABLE UTILITY THE WATER MAIN SHALL BE INSTALLED TO THE SEPARATION REQUIREMENTS OUTLINED IN CITY STD. PLAN 104.
3. THE CITY OF PENDLETON IS PLANNING TO RECONSTRUCT SE 3RD STREET AFTER THE WATER MAIN IMPROVEMENTS ARE COMPLETED. THE STREET RECONSTRUCTION PROJECT WILL BE A SEPARATE PROJECT. HOWEVER, THESE IMPROVEMENTS ARE SHOWN ON THESE PLANS FOR INFORMATIONAL PURPOSES SO THAT THE WATER METERS AND FIRE HYDRANTS ARE LOCATED CORRECTLY.

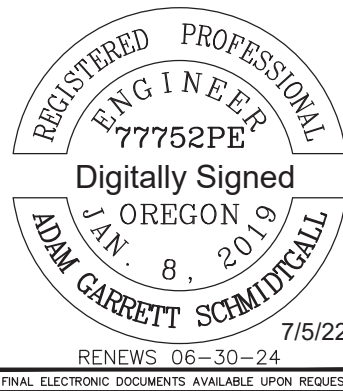
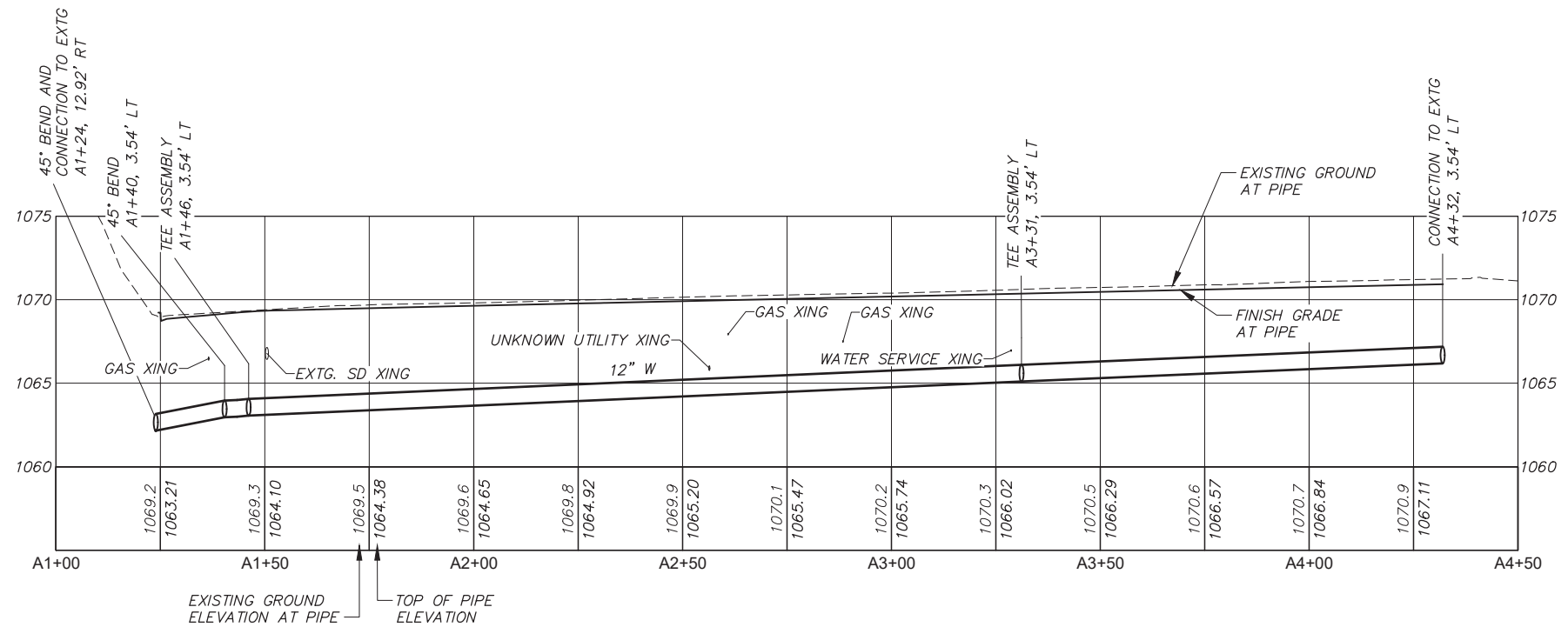
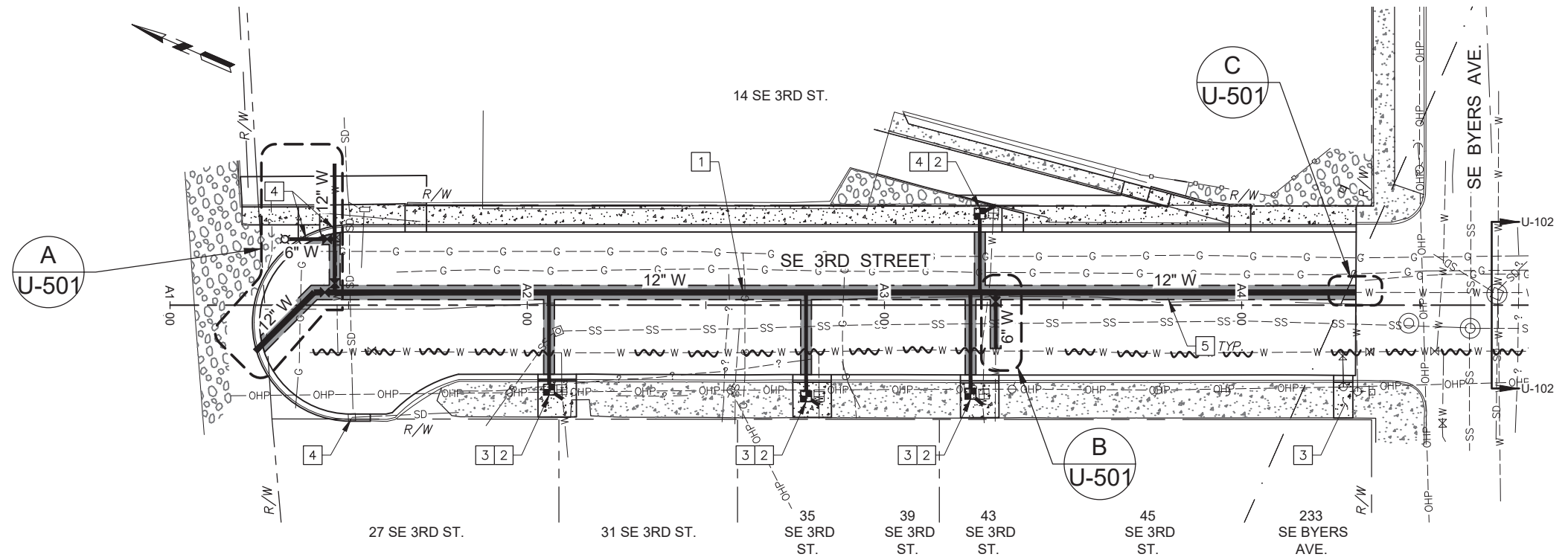

| REVISION | BY | DATE |
|----------|----|------|
| | | |
| | | |
| | | |

| | | |
|---|----------------------------|------------|
| DESIGNED BY: B. VIXIE | JOB NUMBER: 77-58 | DATE: 2022 |
| DRAWN BY: L. WILLHITE | ACAD FILE: 77-58-U-101.dwg | |
| REVIEWED BY: A. SCHMIDTGALL | | |
| COPYRIGHT 2022 BY ANDERSON PERRY & ASSOC., INC. | | |

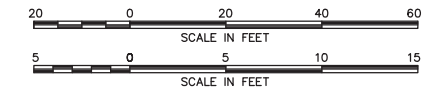

CITY OF PENDLETON, OREGON
SE 3RD STREET WATER MAIN REPLACEMENT
 UTILITIES
 PLAN AND PROFILE STA. A1+00 TO STA. A4+70

SHEET
U-101

WATER WORK ITEMS

1. INSTALL WATER MAIN, SEE CITY STD. PLANS 101, 103, 402, 403, 407A-B, AND 408A-C.
2. EXISTING WATER MAIN AND SERVICES TO REMAIN IN OPERATION UNTIL THE NEW MAIN HAS BEEN FLUSHED, DISINFECTED, AND TESTED. THE CITY WATER CREW WILL INSTALL THE NEW WATER SERVICE AND APPURTENANCES TO THE PROPERTY LINE OR RECONNECT AS NECESSARY. THE CONTRACTOR SHALL BE RESPONSIBLE FOR ALL TRENCHING, BEDDING, BACK FILL, SURFACE RESTORATION, AND COMPACTION. SEE CITY STD. PLAN 409 FOR TYPICAL SERVICE LATERAL INSTALLATION.
3. PATCH CURB, GUTTER, AND SIDEWALK WITH NEW CONCRETE. CURB, GUTTER, AND SIDEWALK TO MATCH EXISTING.
4. PATCH CURB, GUTTER, AND SIDEWALK WITH ASPHALT. SEE DETAIL, SHEET U-502.
5. PATCH ASPHALT IN SE 3RD STREET WITH 2" ASPHALT AND 4" BASE ROCK. TEMPORARY PATCH PER CITY STD. PLAN 103. T-CUT NOT REQUIRED.
6. PATCH ASPHALT IN SE COURT AVE WITH 5" ASPHALT AND 12" BASE ROCK. SEE CITY STD. PLAN 103 AND 201.

NOTES

1. WATER MAINS SHALL BE INSTALLED WITH A MINIMUM OF 36 INCHES OF COVER. WATER MAINS SHALL BE DEEPER THAN 36 INCHES TO AVOID OTHER UTILITIES AND TO LINE UP WITH EXISTING WATER MAIN CONNECTIONS. REFER TO THE PROFILE FOR ADDITIONAL INFORMATION.
2. WHERE THE WATER MAIN CROSSES A NON-POTABLE UTILITY THE WATER MAIN SHALL BE INSTALLED TO THE SEPARATION REQUIREMENTS OUTLINED IN CITY STD. PLAN 104.
3. THE CITY OF PENDLETON IS PLANNING TO RECONSTRUCT SE 3RD STREET AFTER THE WATER MAIN IMPROVEMENTS ARE COMPLETED. THE STREET RECONSTRUCTION PROJECT WILL BE A SEPARATE PROJECT. HOWEVER, THESE IMPROVEMENTS ARE SHOWN ON THESE PLANS FOR INFORMATIONAL PURPOSES SO THAT THE WATER METERS AND FIRE HYDRANTS ARE LOCATED CORRECTLY.

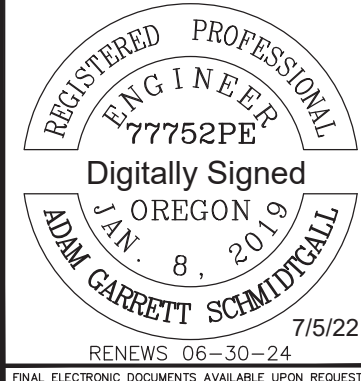
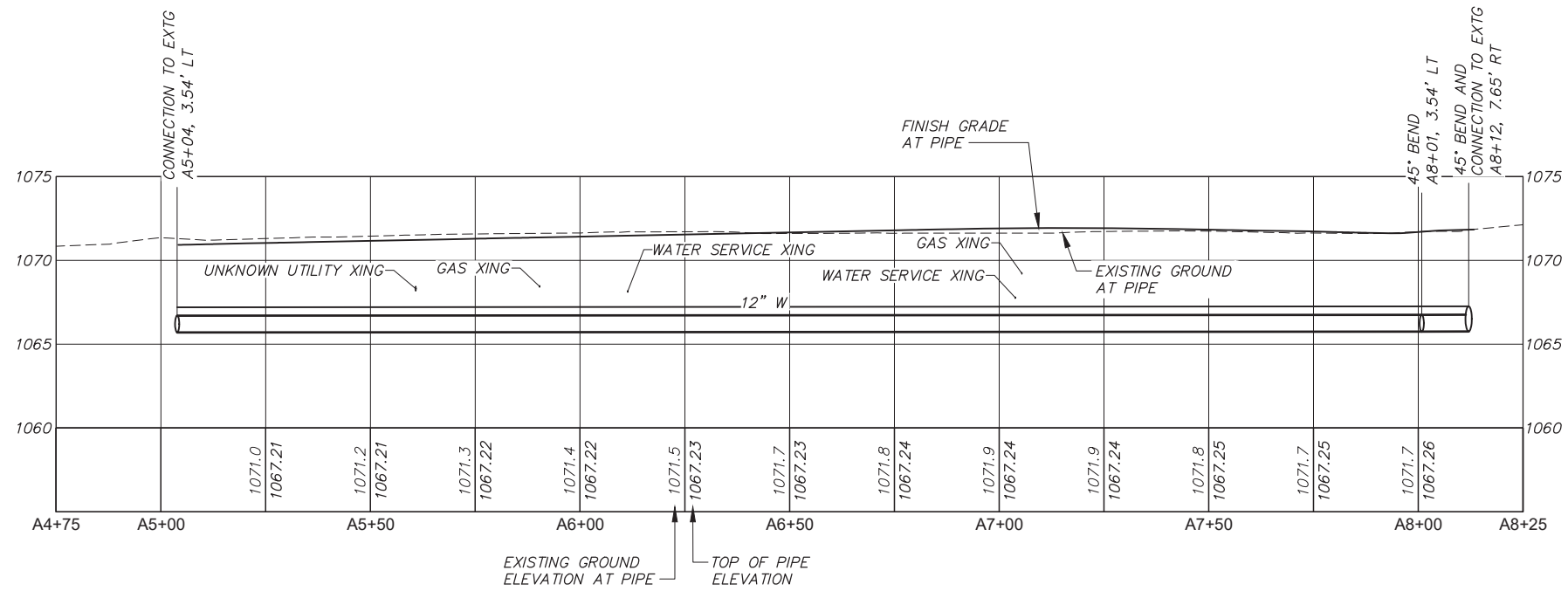
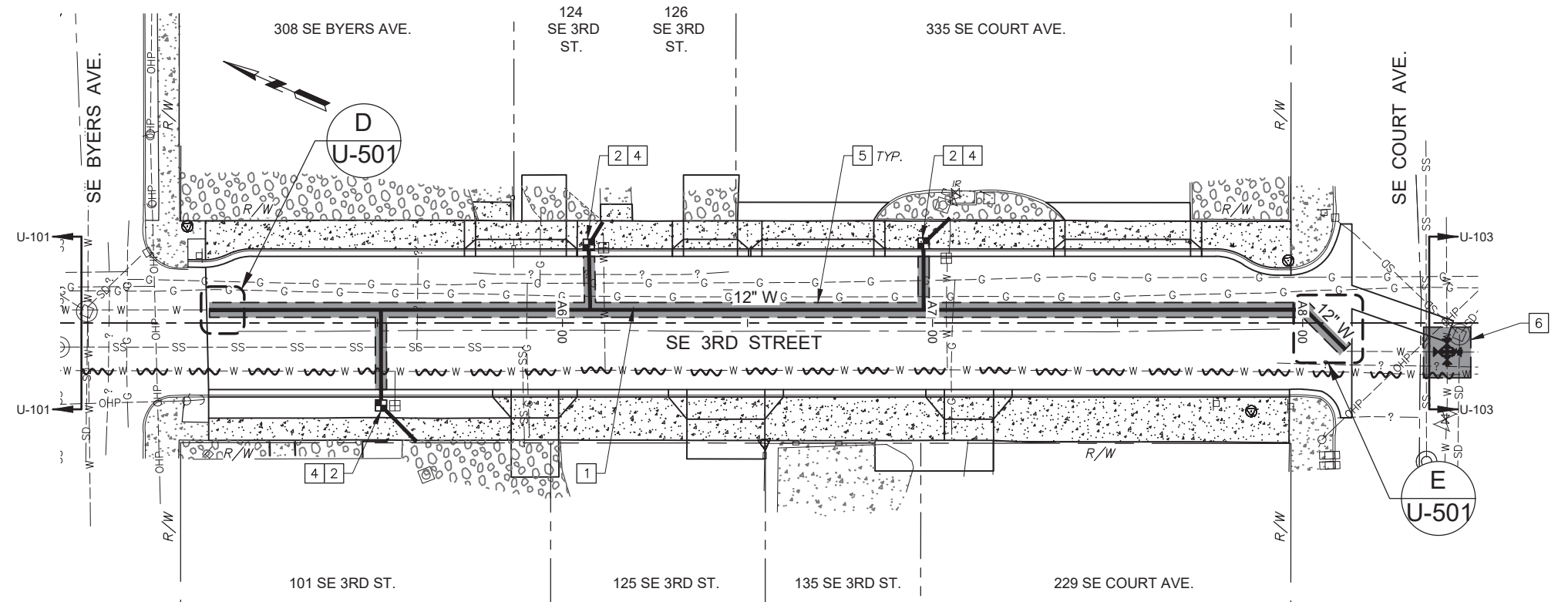

| REVISION | BY | DATE |
|----------|----|------|
| | | |
| | | |
| | | |

| | | |
|-----------------------------|----------------------------|------------|
| DESIGNED BY: B. VIXIE | JOB NUMBER: 77-58 | DATE: 2022 |
| DRAWN BY: L. WILLHITE | ACAD FILE: 77-58-U-102.dwg | |
| REVIEWED BY: A. SCHMIDTGALL | | |

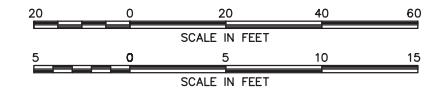

CITY OF PENDLETON, OREGON
SE 3RD STREET WATER MAIN REPLACEMENT
 UTILITIES
 PLAN AND PROFILE STA. A4+70 TO STA. A8+40

SHEET
U-102

WATER WORK ITEMS

1. INSTALL WATER MAIN, SEE CITY STD. PLANS 101, 103, 402, 403, 407A-B, AND 408A-C.
2. EXISTING WATER MAIN AND SERVICES TO REMAIN IN OPERATION UNTIL THE NEW MAIN HAS BEEN FLUSHED, DISINFECTED, AND TESTED. THE CITY WATER CREW WILL INSTALL THE NEW WATER SERVICE AND APPURTENANCES TO THE PROPERTY LINE OR RECONNECT AS NECESSARY. THE CONTRACTOR SHALL BE RESPONSIBLE FOR ALL TRENCHING, BEDDING, BACK FILL, SURFACE RESTORATION, AND COMPACTION. SEE CITY STD. PLAN 409 FOR TYPICAL SERVICE LATERAL INSTALLATION.
3. PATCH CURB, GUTTER, AND SIDEWALK WITH NEW CONCRETE. CURB, GUTTER, AND SIDEWALK TO MATCH EXISTING.
4. PATCH CURB, GUTTER, AND SIDEWALK WITH ASPHALT. SEE DETAIL, SHEET U-502.
5. PATCH ASPHALT IN SE 3RD STREET WITH 2" ASPHALT AND 4" BASE ROCK. TEMPORARY PATCH PER CITY STD. PLAN 103. T-CUT NOT REQUIRED.
6. PATCH ASPHALT IN SE COURT AVE WITH 5" ASPHALT AND 12" BASE ROCK. SEE CITY STD. PLAN 103 AND 201.

NOTES

1. WATER MAINS SHALL BE INSTALLED WITH A MINIMUM OF 36 INCHES OF COVER. WATER MAINS SHALL BE DEEPER THAN 36 INCHES TO AVOID OTHER UTILITIES AND TO LINE UP WITH EXISTING WATER MAIN CONNECTIONS. REFER TO THE PROFILE FOR ADDITIONAL INFORMATION.
2. WHERE THE WATER MAIN CROSSES A NON-POTABLE UTILITY THE WATER MAIN SHALL BE INSTALLED TO THE SEPARATION REQUIREMENTS OUTLINED IN CITY STD. PLAN 104.
3. THE CITY OF PENDLETON IS PLANNING TO RECONSTRUCT SE 3RD STREET AFTER THE WATER MAIN IMPROVEMENTS ARE COMPLETED. THE STREET RECONSTRUCTION PROJECT WILL BE A SEPARATE PROJECT. HOWEVER, THESE IMPROVEMENTS ARE SHOWN ON THESE PLANS FOR INFORMATIONAL PURPOSES SO THAT THE WATER METERS AND FIRE HYDRANTS ARE LOCATED CORRECTLY.

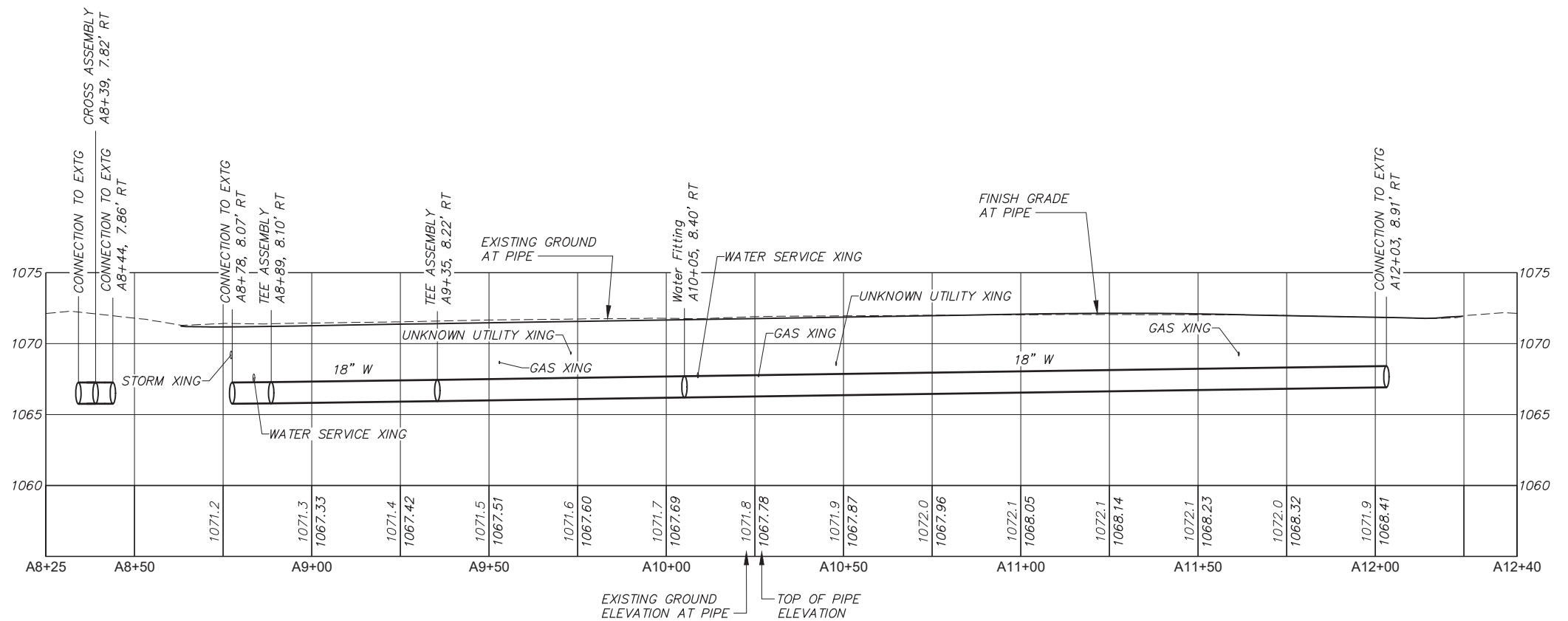
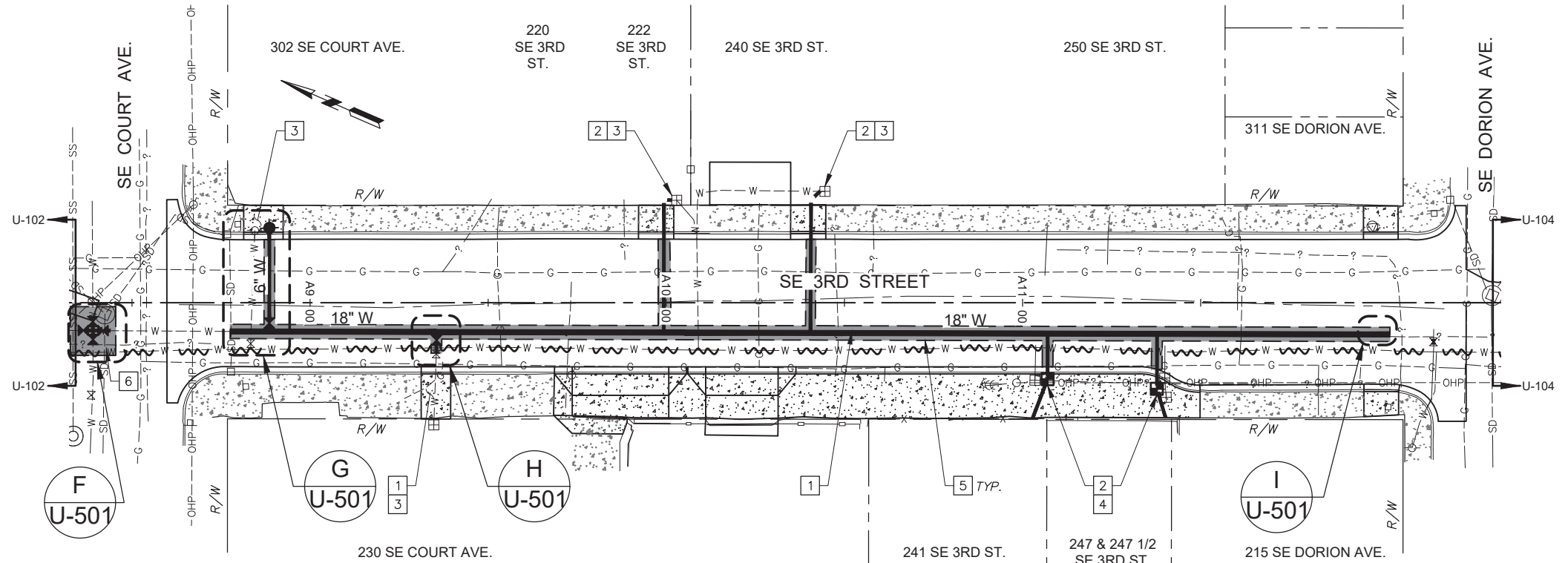

| REVISION | BY | DATE |
|----------|----|------|
| | | |
| | | |
| | | |

| | | |
|-----------------------------|----------------------------|------------|
| DESIGNED BY: B. VIXIE | JOB NUMBER: 77-58 | DATE: 2022 |
| DRAWN BY: L. WILLHITE | ACAD FILE: 77-58-U-103.dwg | |
| REVIEWED BY: A. SCHMIDTGALL | | |

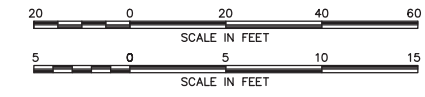

CITY OF PENDLETON, OREGON
SE 3RD STREET WATER MAIN REPLACEMENT
 UTILITIES
 PLAN AND PROFILE STA. A8+40 TO STA A12+40

SHEET
U-103

WATER WORK ITEMS

1. INSTALL WATER MAIN, SEE CITY STD. PLANS 101, 103, 402, 403, 407A-B, AND 408A-C.
2. EXISTING WATER MAIN AND SERVICES TO REMAIN IN OPERATION UNTIL THE NEW MAIN HAS BEEN FLUSHED, DISINFECTED, AND TESTED. THE CITY WATER CREW WILL INSTALL THE NEW WATER SERVICE AND APPURTENANCES TO THE PROPERTY LINE OR RECONNECT AS NECESSARY. THE CONTRACTOR SHALL BE RESPONSIBLE FOR ALL TRENCHING, BEDDING, BACK FILL, SURFACE RESTORATION, AND COMPACTION. SEE CITY STD. PLAN 409 FOR TYPICAL SERVICE LATERAL INSTALLATION.
3. PATCH CURB, GUTTER, AND SIDEWALK WITH NEW CONCRETE. CURB, GUTTER, AND SIDEWALK TO MATCH EXISTING.
4. PATCH CURB, GUTTER, AND SIDEWALK WITH ASPHALT. SEE DETAIL, SHEET U-502.
5. PATCH ASPHALT IN SE 3RD STREET WITH 2" ASPHALT AND 4" BASE ROCK. TEMPORARY PATCH PER CITY STD. PLAN 103. T-CUT NOT REQUIRED.
6. PATCH ASPHALT IN SE COURT AVE WITH 5" ASPHALT AND 12" BASE ROCK. SEE CITY STD. PLAN 103 AND 201.

NOTES

1. WATER MAINS SHALL BE INSTALLED WITH A MINIMUM OF 36 INCHES OF COVER. WATER MAINS SHALL BE DEEPER THAN 36 INCHES TO AVOID OTHER UTILITIES AND TO LINE UP WITH EXISTING WATER MAIN CONNECTIONS. REFER TO THE PROFILE FOR ADDITIONAL INFORMATION.
2. WHERE THE WATER MAIN CROSSES A NON-POTABLE UTILITY THE WATER MAIN SHALL BE INSTALLED TO THE SEPARATION REQUIREMENTS OUTLINED IN CITY STD. PLAN 104.
3. THE CITY OF PENDLETON IS PLANNING TO RECONSTRUCT SE 3RD STREET AFTER THE WATER MAIN IMPROVEMENTS ARE COMPLETED. THE STREET RECONSTRUCTION PROJECT WILL BE A SEPARATE PROJECT. HOWEVER, THESE IMPROVEMENTS ARE SHOWN ON THESE PLANS FOR INFORMATIONAL PURPOSES SO THAT THE WATER METERS AND FIRE HYDRANTS ARE LOCATED CORRECTLY.

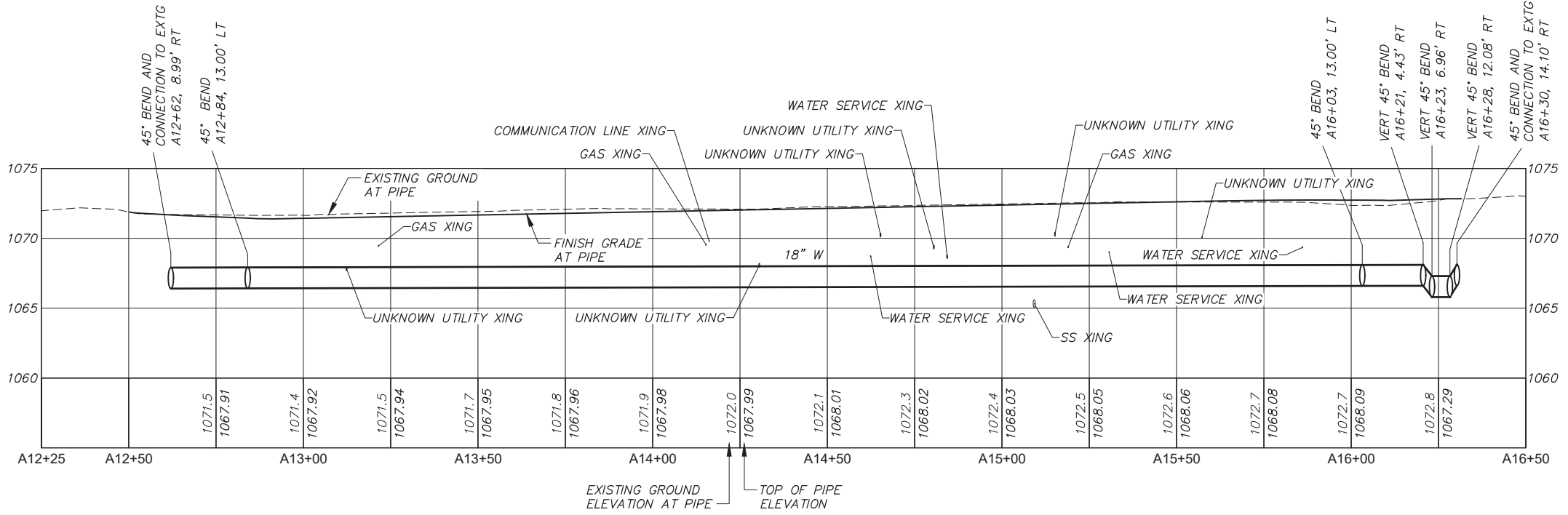
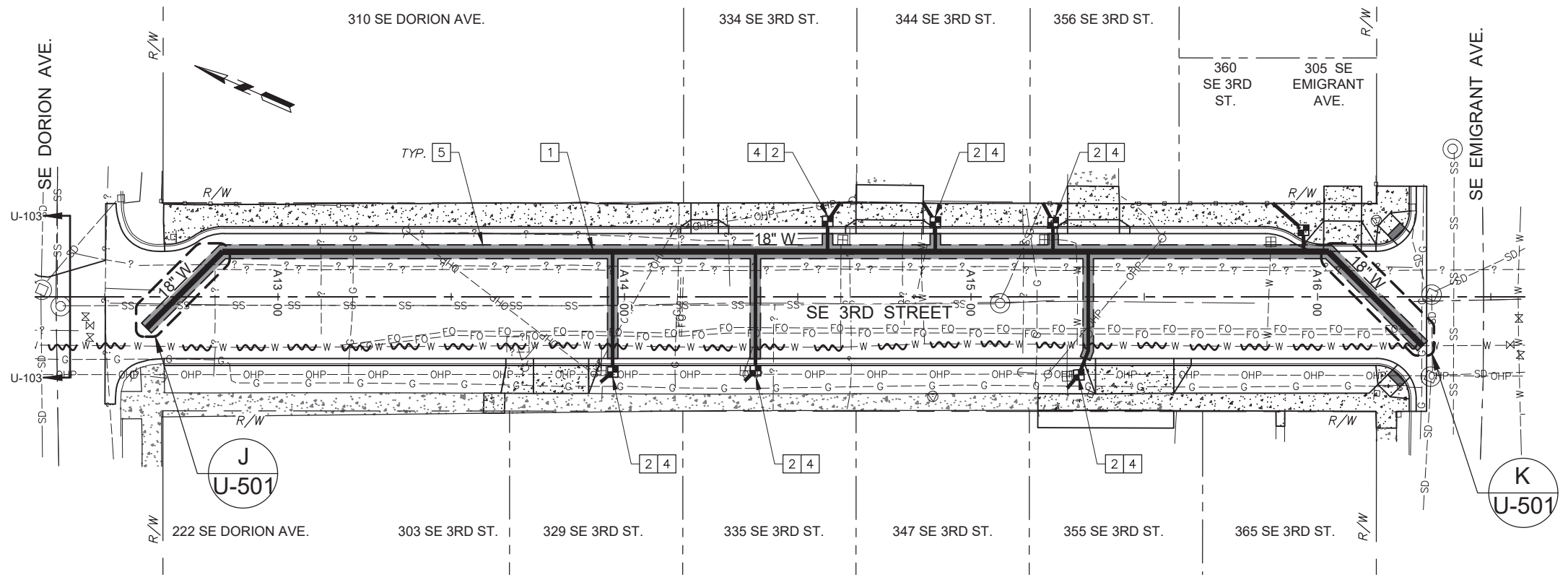

REGISTERED PROFESSIONAL ENGINEER
 77752PE
 Digitally Signed
 J. OREGON
 ADAM GARRETT SCHMIDTGALL
 7/5/22
 RENEWS 06-30-24
FINAL ELECTRONIC DOCUMENTS AVAILABLE UPON REQUEST

| | |
|-------------|----------------|
| DESIGNED BY | B. VIXIE |
| DRAWN BY | L. WILLHITE |
| REVIEWED BY | A. SCHMIDTGALL |

| | | | |
|---|-----------------|------|------|
| JOB NUMBER | 77-58 | DATE | 2022 |
| ACAD FILE: | 77-58-U-104.dwg | | |
| COPYRIGHT 2022 BY ANDERSON PERRY & ASSOC., INC. | | | |

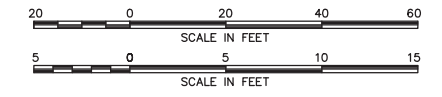

anderson perry
 & associates, inc.
engineering • surveying • natural resources

CITY OF PENDLETON, OREGON
SE 3RD STREET WATER MAIN REPLACEMENT
 UTILITIES
 PLAN AND PROFILE STA. 12+40 TO STA. A16+50

SHEET
U-104

FITTING SCHEDULE

- 1 EXISTING 4" PIPE
- 2 EXISTING 6" PIPE
- 3 EXISTING 12" PIPE
- 4 EXISTING 16" PIPE
- 5 EXISTING 18" PIPE
- 6 EXISTING 18" PIPE (EMPTY)
- 7 NEW 4" PIPE
- 8 NEW 6" PIPE
- 9 NEW 12" PIPE
- 10 NEW 18" PIPE
- 11 4" FLGxMJ GATE VALVE
- 12 6" FLGxMJ GATE VALVE
- 13 12" FLGxMJ GATE VALVE
- 14 12" COUPLING
- 15 18" COUPLING
- 16 12"x6" MJxFLG TEE
- 17 12" FLG TEE
- 18 12" MJ 45° ELBOW
- 19 FIRE HYDRANT
- 20 6" COUPLING
- 21 IF THE NEW WATERLINE IN BYERS IS ALREADY INSTALLED, REMOVE CAP AND INSTALL COUPLING. IF THE WATER LINE IN BYERS AVENUE IS NOT ALREADY INSTALLED, INSTALL MJ CAP.
- 22 18" MJ 45° ELBOW
- 23 REMOVE CAP AND INSTALL COUPLING ON EMPTY 18" PIPE IN COURT AVENUE
- 24 REMOVE EXISTING FIRE HYDRANT
- 25 REMOVE EXISTING VALVE AND BOX
- 26 18"x6" MJxFLG TEE
- 27 4" COUPLING
- 28 4" MJ 45° BEND
- 29 6"x4" FLG REDUCER
- 30 REMOVE 45° BEND AND RESTRAINTS AND INSTALL 18" COUPLING IN DORION AVENUE
- 31 6" MJ 45° BEND
- 32 8"x6" FLGxMJ REDUCER
- 33 18" FLGxMJ ADAPTER
- 34 18"x8" FLG CROSS
- 35 8" FLG GATE VALVE
- 36 18" FLGxMJ GATE VALVE
- 37 12" MJ 45° BEND
- 38 12"x18" FLGxMJ REDUCER
- 39 12" FLGxMJ 45° BEND
- 40 12" FLGxMJ ADAPTER

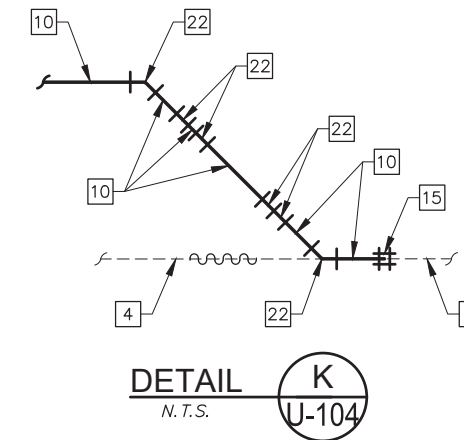
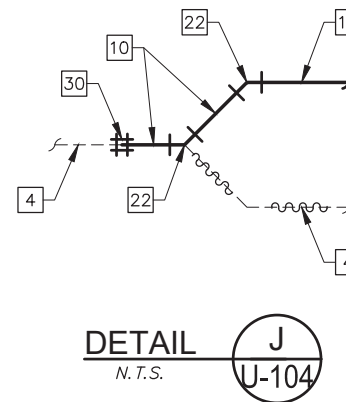
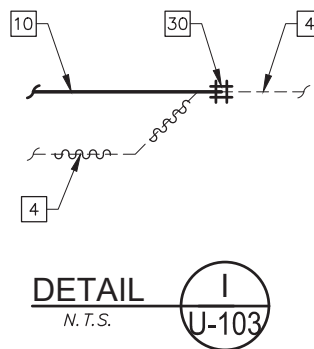
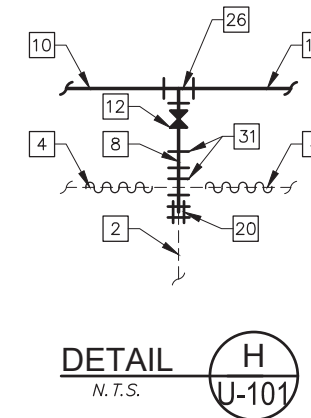
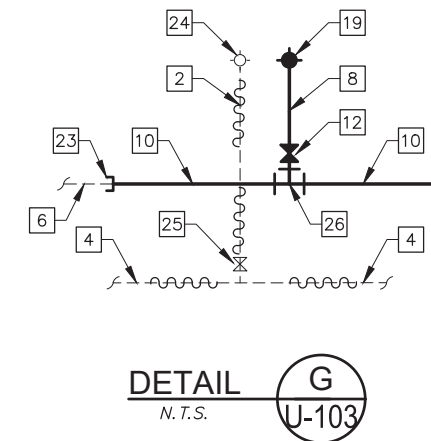
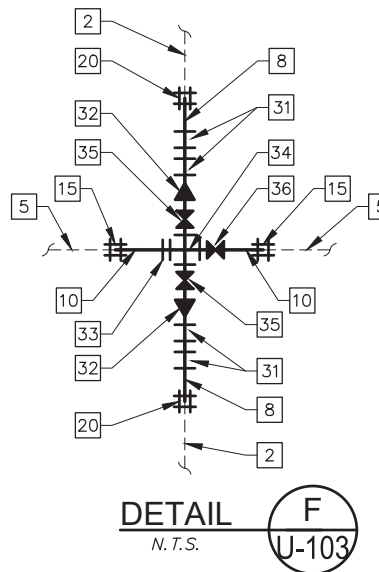
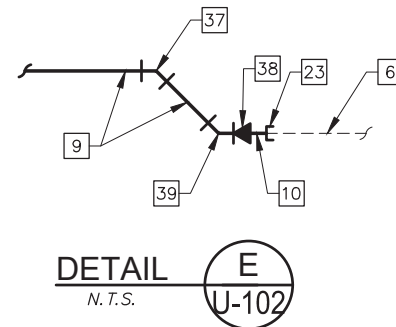
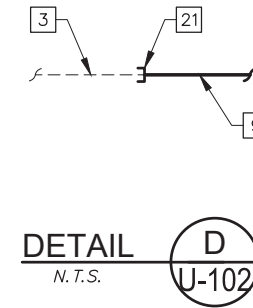
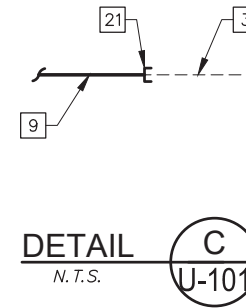
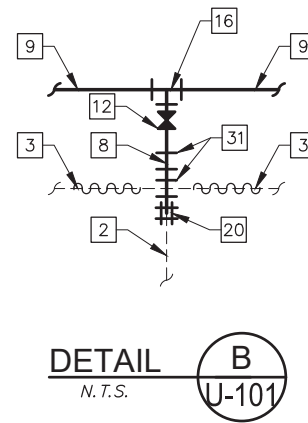
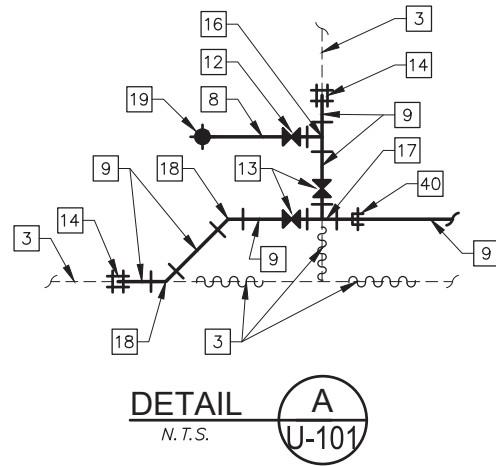

| | | | |
|---|----------------|------------|-----------------|
| DESIGNED BY | B. VIXIE | DATE | 2022 |
| DRAWN BY | L. WILLHITE | JOB NUMBER | 77-58 |
| REVIEWED BY | A. SCHMIDTGALL | ACAD FILE: | 77-58-U-501.dwg |
| REVISION | | BY | DATE |
| | | | |
| | | | |
| COPYRIGHT 2022 BY ANDERSON PERRY & ASSOC., INC. | | | |



CITY OF PENDLETON, OREGON
SE 3RD STREET WATER MAIN REPLACEMENT

DETAILS I

SHEET
U-501

WORK ITEMS

- ① 2" COMPACTED LEVEL 3 HMAC 1/2" DENSE
- ② HMAC CURB AND GUTTER
ROLL UP TO MATCH EXISTING CURB HEIGHT
- ③ 4" COMPACTED 3/4"-0 BASE ROCK
- ④ REPLACE TOPSOIL IN LANDSCAPED AREAS
- ⑤ SERVICE LINE
- ⑥ TRENCH BACKFILL AND BEDDING
SEE CITY STD. PLAN 103

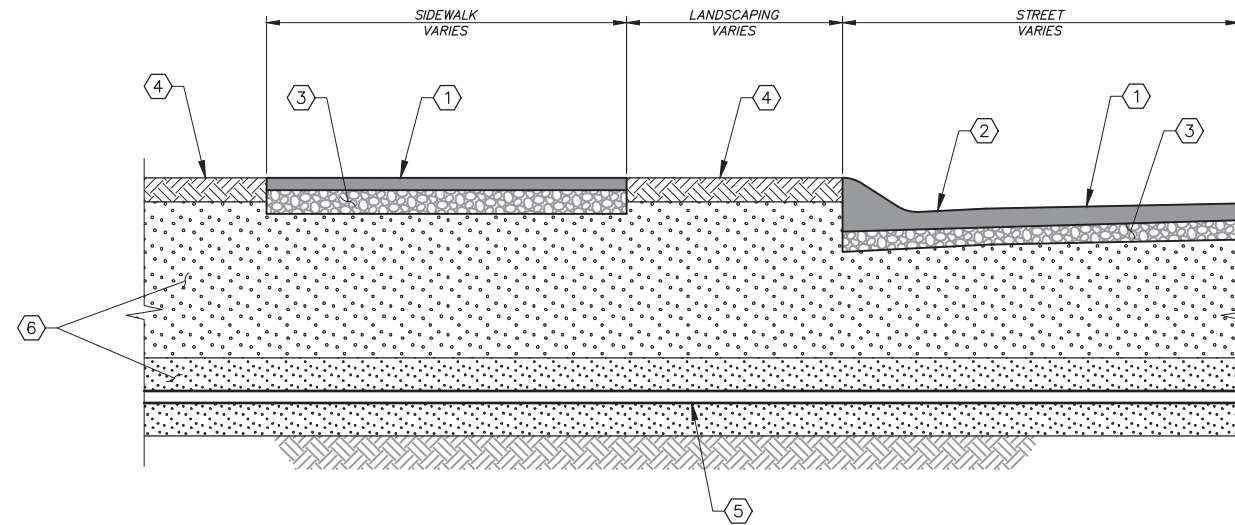

HMAC STREET, CURB, GUTTER, & SIDEWALK PATCH
SECTION
N.T.S.

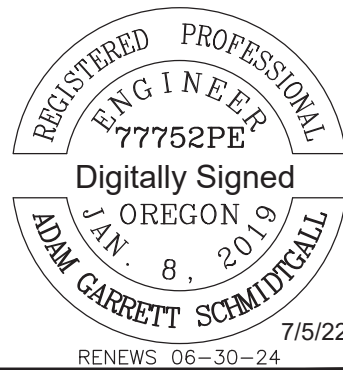

| | | | | | | |
|-------------|----------------|------|---|-----------------|------|------|
| REVISION | BY | DATE | JOB NUMBER | 77-58 | DATE | 2022 |
| DESIGNED BY | B. VIXIE | | ACAD FILE: | 77-58-U-502.dwg | | |
| DRAWN BY | L. WILLHITE | | COPYRIGHT 2022 BY ANDERSON PERRY & ASSOC., INC. | | | |
| REVIEWED BY | A. SCHMIDTGALL | | | | | |



CITY OF PENDLETON, OREGON
SE 3RD STREET WATER MAIN REPLACEMENT

DETAILS II

SHEET

U-502