

CITY OF PENDLETON

2022 City Streets Overlay & Reconstruction Project

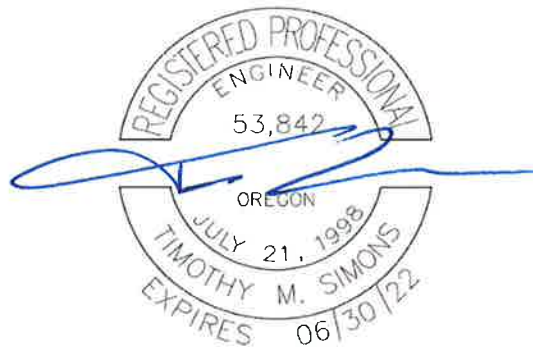

Stamped: MAR 16 2022

March 2022

Engineering Department
500 SW Dorion Avenue
Pendleton, OR 97801
www.pendleton.or.us
Office (541) 966-0203
Fax (541) 966-0251

TABLE OF CONTENTS

INVITATION TO BID..... 1.00

INFORMATION FOR BIDDERS

PREQUALIFICATION 2.00

BID PROPOSAL 3.00

BID BOND 4.00

STATUTORY PUBLIC WORKS BOND..... 5.00

CONTRACT 6.00

ASSIGNMENT OF ANTITRUST RIGHTS..... 7.00

NON-COLLUSION AFFIDAVIT 8.00

PERFORMANCE/PAYMENT BOND..... 9.00

CERTIFICATE OF INSURANCE 10.00

SPECIAL CONDITIONS 11.00

IRS FORM W-9 (Taxpayer ID number and certification)..... 12.00

SPECIAL SPECIFICATIONS..... 13.00

DRAWINGS..... 14.00

INVITATION TO BID

Sealed bids for the **2022 City Streets Overlay & Reconstruction Project** will be received by the City of Pendleton c/o Tim Simons, Community Development Director, City of Pendleton, 500 SW Dorion Avenue, Pendleton, OR 97801 until **2:30 pm local time on the 7th day of April, 2022**, plainly marked “**2022 City Streets Overlay & Reconstruction Project**”. Public bid opening will be available via Zoom or at the Community Development Department at City Hall, same address as above, at 2:30 pm local time, April 7, 2022. Contact the Community Development Department at 541 966-0203 or Jutta Haliewicz, jutta.haliewicz@ci.pendleton.or.us, 541 966-0240, for the Zoom link.

Bid documents may be obtained for a **non-refundable fee of \$25.00** from the Community Development Department located at the same address as above or by calling (541) 966-0203. Bid documents are also available online at the **OregonBuys website**: <https://oregonbuys.gov/bs0/view/login/login.xhtml> or on the **City of Pendleton’s website** www.pendleton.or.us/rfps. For the nearest location of a review copy, also contact the Community Development Department. Bid documents will be available until 5:00 pm, April 4, 2022.

The Oregon Standard Specifications for Construction (ODOT/APWA) latest revision, excluding Sections 00100 and 00745.95, and the City of Pendleton Standard Specifications will apply to all construction work not noted in the Special Specifications. It is the Contractor’s responsibility to obtain the latest revisions made to these specifications (latest revisions to City Standard Specifications, January 2001 with minor revisions 2001, 2004, 2005, 2006 and 2012).

All bidders must be prequalified for the class of work included in this bid document in accordance with the laws of the State of Oregon, and all prequalification applications must be submitted to the City by 1:00 pm April 6, 2022, the day before the bid opening. (See Section 2.00)

The City of Pendleton will not mail notice of Addenda, but will post notice of any Addenda on the OregonBuys website and the City’s website (www.pendleton.or.us/rfps). Addenda may be downloaded off these websites and will be faxed or emailed to all bidders who have requested to be on the City’s Planholders List. Contact jutta.haliewicz@ci.pendleton.or.us to be added to the list. Bidders should frequently check the websites until bid closing.

Each Bid Proposal must be submitted on the prescribed form (Section 3.00) accompanied by a certified or cashier check drawn from an Oregon Bank in good standing, or banks doing business in Oregon in good standing, or a Bid Bond issued by a surety company authorized to issue such bonds in the State of Oregon, payable to the City of Pendleton, Oregon, in an amount not less than five percent (5%) of the total amount of the Bid submitted.

All bidders must comply with ORS Chapter 279C and pay applicable prevailing wage rates in effect on January 1, 2022, including any amendments, as stated in the Prevailing Wage Rates for Public Works Contracts in Oregon published by the Oregon Bureau of Labor and Industries (see www.oregon.gov/boli).

The successful bidder will be required to furnish a bond for faithful performance of the contract in the full amount of the contract price. In addition to required performance bonds which may be used for unpaid wages, all contractors, subcontractors and non-construction companies working on public works projects, with a contract price that exceeds \$100,000, subject to the Prevailing Wage Rate law must file a \$30,000 Public Works Bond with the Construction Contractor’s Board before starting work on the project, unless exempt, to be used exclusively for unpaid wages determined to be due by BOLI. {ORS 279C.830 and ORS 279C.836} **(See forms included in Section 5.00)**

Each bidder must identify whether they are a resident bidder as defined in ORS 279A.120. (Preference for Oregon goods and services)

Nonresident Bidders: ORS 279A.120(3) states: "When a public contract is awarded to a nonresident bidder and the contract price exceeds \$10,000, the bidder shall promptly report to the Department of Revenue (DOR) on forms to be provided by the department the total contract price, terms of payment, length of contract and such other information as the department may require before the bidder may receive final payment on the public contract. The contracting agency shall satisfy itself that the requirement of this subsection has been complied with before the contracting agency issues a final payment on a public contract." See form attached to the end of Special Conditions (Section 11.00). For information about DOR requirements, contact: <http://www.oregon.gov/DOR>

The Contractor shall, within two (2) working hours of the advertised bid opening, submit the first-tier subcontractor disclosure form. This form is to notify the Community Development Director in writing the names of the first-tier subcontractors. The disclosure form is attached to the end of the Special Conditions (Section 11.00). If no subcontractors need to be disclosed, enter "NONE" on the form and submit it.

The Contractor, its subcontractors, if any, and all employers working under this Contract are subject employers under the Oregon Workers' Compensation law and shall comply with ORS Chapter 656, which requires them to provide workers' compensation coverage for all their subject workers.

The City reserves the right to accept that proposal which is in the best interest of the City of Pendleton, Oregon and to postpone the award of the Contract for a period not to exceed thirty (30) calendar days.

The deadline for filing a protest by the second responsible bidder is seven (7) calendar days after the Notice of Intent to Award has been issued. Protest must be in written form and received by 5:00 pm on the 7th day from the date of the letter of intent to award issued by the Community Development Director. Once the Notice of Intent to Award has been issued, bid submittal information will be available for public review.

Dated this 16th day of March, 2022.



Timothy M. Simons, Community Development Director

INFORMATION FOR BIDDERS

City of Pendleton, hereby referred to as OWNER, will be completing work under one contract for the **2022 City Streets Overlay & Reconstruction Project**. Bids are expected to be opened at **2:30 pm, local time, Thursday, April 7, 2022**. Bid award, with seven (7) calendar day notice of intent declaration, will likely take place on Tuesday, April 19, 2022, at the regularly scheduled City Council meeting, 7:00 pm, City Hall, 500 SW Dorion Avenue, Pendleton, Oregon. Virtual meeting attendance is available by visiting City of Pendleton website.

Work to be performed consists of overlays and reconstructions on City streets. This Project shall include the removal and replacement with approximately 1,623.50 LF of City standard curb and gutter, and 453.50 SY of ADA ramps. There will also be 4,993.00 tons of asphalt placed for this project, 79 utility adjustments, and 5,725.00 LF of traffic striping. See Special Specifications (Section 13) and Plan Drawings for more details regarding this project.

The above information is a general outline of principal features of the work. It does not in any way limit the responsibility of the CONTRACTOR(s) to perform all work and furnish all equipment, labor and materials required by the specifications and drawings. The drawings and specifications shall be considered and used together. Anything appearing as a requirement of either shall be accepted as applicable to both even though not so stated therein or shown.

Engineer's estimate: \$1,643,651.06

Bidders must submit the following completed documents with their bids by the bid due date (April 7, 2022) and time (2:30 pm) indicated on the Invitation to Bid (Section 1.00) or as stated on any addendum(s) stating otherwise. **Bids not containing the following items may be considered non-responsive:**

- **Bid Proposal – form signed by company representative having authority to submit bids – see Section 3.00**
- **Bid Bond/Security (5%) in form of certified or cashier's check drawn from an Oregon Bank – see Section 4.00**
- **Acknowledgement of ALL Addenda**
- **Non-Collusion Affidavit (signed by company representative and notarized) – see Section 8.00**

Bidder shall, within two (2) working hours of the advertised bid opening, submit the first-tier subcontractor disclosure form – see Section 11.00

Upon award of contract the SUCCESSFUL BIDDER must be prepared to submit the following completed documents within ten (10) business days of contract award:

Contract Forms and Submittals:

- Three original signed contracts (provided by City)
- Copy of Statutory Public Works Bond
- Performance and Payment Bond
- Certificate of Liability Insurance
- Oregon Nonresident Bidder Form (if applicable)
- IRS Form W-9
- Application and payment for City Business License (Contractor and any subcontractors)
- Signed copy of Special Conditions (Section 11.00)
- BOLI Wage Rate Worksheet (indicating BOLI Wage Rates used for the project)
 - Example worksheet attached
- Construction Schedule

PREQUALIFICATION

PUBLIC WORKS DEPARTMENT
CITY OF PENDLETON
PENDLETON, OREGON

Oregon Law requires a statement as to financial ability, equipment and experience to be completed and submitted by prospective contractors bidding on contracts for public improvements, the estimated cost of which is \$10,000 or over. No contractor is eligible to bid until this statement has been submitted. All prequalifications must be submitted to the City by **1:00 pm the day before the bid opening.** (See Section 1.07 Prequalification of Bidders for Public Works Projects, City of Pendleton Standard Specifications.)

Upon request, this application is available to you through this office at 541 966-0203 or online at <https://pendleton.or.us/cdev/page/prequalification-application-2022> for your use in prequalification for this work.

PROPOSAL

Honorable Mayor and City Council
City Hall
Pendleton, Oregon 97801

The undersigned, hereinafter called the Bidder, declares that the only persons or parties interested in this Proposal are those named herein, that the Proposal is in all respects fair and without fraud, but it is made without collusion with any official or employee of the City of Pendleton, Oregon, and that the Proposal is made without any connection or collusion with any person making another Proposal on this Contract.

The Bidder further declares that he has carefully examined the Contract Documents for the construction of the proposed improvements, and he has personally inspected the site, and he has satisfied himself as to the quantities of the materials, items of equipment, and conditions of work involved, including the fact that the description of the work and materials, as included herein, is brief and is intended only to indicate the general nature of such items and to identify the said quantities with the detailed requirements of the Contract Documents, and that this Proposal is made according to the provisions and under the terms of the Contract Documents, which Documents are hereto attached and are hereby made a part of this Proposal.

The Bidder agrees that if this Proposal is accepted, he will, within ten (10) calendar days after notification of acceptance, execute the Contract with the City of Pendleton, Oregon, in the form of Contract annexed thereto, and will, at the time of execution of the Contract, deliver to the City of Pendleton, the Performance Bond required herein, and will to the extent of his Proposal, furnish all machinery, tools, and apparatus and other means of construction and do all the work and furnish all the materials necessary to complete the work in the manner and in the time and according to the methods as specified in the Contract Documents and required by the Engineer there under.

The Bidder agrees to complete the work identified for each schedule of work at the option of the City of Pendleton. The City, at its sole discretion, will identify and select the schedules of work that best fit the City's budget for this work. The City does not intend to award schedules separately.

In the event the Bidder is awarded the Contract and shall fail to complete the work within the time limit or extended time limit agreed upon, as more particularly set forth in the Contract Documents, liquidated damages shall be paid to the City of Pendleton, Oregon, at the rate of one percent (1%) per day of total cost of work not yet completed for each of the contract schedules (or streets), or \$500 per calendar day for each schedule, whichever is greater for all work not yet completed by the contract deadline, **August 26, 2022**, or work progression timeline, whichever occurs first (**See Special Specifications, Section 13.00**). Sundays and legal holidays shall be excluded in determining days of default.

The Bidder further proposes to accept as full payment for the work proposed herein the amount computed under the provisions of the Contract Documents and based on the following unit price amounts, it being expressly understood that the unit prices are independent of the exact quantities involved, that they represent a true measure of the labor and material required to perform the work, including all allowances for overhead and profit for each type and unit of work called for in these Contract Documents.

The Contract will be awarded based on bids. City reserves the right to award or reject the bids that are in the best interest of the City.

Bidders must submit the following completed documents with their bids by the bid due date (**April 7, 2022**) and time (**2:30 pm**) indicated on the Invitation to Bid (Section 1.00) or as stated on any addendum(s) stating otherwise. **Bids not containing the following items may be considered non-responsive:**

- **Bid Proposal form (dated and signed by company representative having authority to submit bids) – Section 3.00**
- **Bid Security – Section 4.00**
- **Acknowledgement of all Addenda**
- **Non-Collusion Affidavit (signed by company representative and notarized) – Section 8.00**

The following instructions outline the procedure for preparing and submitting Bids. Bidders must fulfill all requirements as specified in this Contract Document:

- Prequalification must be submitted by 1:00 p.m. the day before the bid opening date **(bid opening April 7, 2022)**.
- A bid amount shall be submitted in the appropriate place for each street for which a bid is being submitted as well as a grand total bid for the complete project.
- Bid will be awarded based on grand total bid amount. Separate schedules or streets will not be awarded to more than one general contractor.
- Bidders shall use only the Bid Proposal form provided in this Contract Document. All blank spaces in the Bid Proposal form must be filled in completely where required. No changes shall be made in the phraseology of the forms.
- The Bid Proposal form may be submitted separately from the remainder of these Contract Documents. It must be submitted in a sealed envelope and marked clearly to indicate its contents without being opened.
- **The Bidder shall acknowledge receipt of all Addenda to the Bid. Bids received without acknowledgement or without the Addenda enclosed may be considered nonconforming. Notice of Addenda will not be mailed but will be posted on City's website (www.pendleton.or.us/rfps) and the OregonBuys website (<https://oregonbuys.gov/bsa/view/login/login.xhtml>). Addenda may be downloaded off website and will be faxed or emailed to all bidders who have notified City to request their firm be placed on the Planholders list. Bidders should frequently check the websites until bid closing.**
- Any taxes required by the laws and statutes of the State of Oregon and its political subdivisions shall be paid by the Contractor.
- Owner will pay all permit expenses with the exception of temporary permits related to construction work. The successful Bidder must pay all temporary permit expenses.
- All Bids must be submitted no later than the prescribed time, place, and manner set forth in the Contract Documents.
- Bids without sufficient data to provide a complete evaluation may not be considered.
- Any Bidder may modify its Bid by telegraphic or written communication at any time prior to the scheduled closing time for receipt of the Bids, provided the Owner receives such communication prior to the closing time. The telegraphic or written communication should not reveal the Bid Amount; however, it should state the addition, subtraction, or other modification so that the final amount or terms will not be known to the Owner until the sealed Bid is opened.
- Bids cannot be modified at any time following the deadline for receipt of the Bids.
- **Bids must be accompanied by a certified or cashier check drawn from an Oregon Bank in good standing, or banks doing business in Oregon in good standing, or a Bid Bond issued by a surety company authorized to issue such bonds in the State of Oregon, in an amount not less than five percent (5%) of the total amount of the Bid submitted.** This check or Bid Bond shall be given as guarantee that if awarded the Contract, the successful Bidder will execute the Contract within the time specified. See Standard Specifications for the City of Pendleton – Section 1:06 – Bid Security for more information. **(See Section 4.00)**
- **Non-Collusion Affidavit must be submitted with the Bid; otherwise, the Bid may be considered non-responsive. (See Section 8.00)**
- **First-Tier Subcontractor Disclosure Form must be submitted by the date and time designated in the Invitation to Bid. This Form must be submitted separately for each Schedule, even if there are no Subcontractors that need to be disclosed; otherwise, the Bid will be considered non-responsive. See Special Conditions (Section 11.00) for more information and a copy of the Disclosure Form.**

The Owner will make the award of work based on the best interests of the City of Pendleton. The Owner also reserves the right to reject any or all bids and to postpone the award of the work for a period not to exceed thirty (30) calendar days with time extensions for completion date. The Owner, at its sole discretion, reserves the right to select the bid(s) most beneficial to the City of Pendleton.

2022 CITY STREETS OVERLAY & RECONSTRUCTION PROJECT

Time of Completion: **No later than August 26, 2022**

SW 37th Street (SW Southgate Place to SW Jay Avenue) Overlay

<u>Item No.</u>	<u>Approx. Quantity</u>	<u>Item with Unit Price Bid</u>	<u>Unit Price</u>	<u>Extended Total</u>
1.	JOB	Mobilization	_____	_____
2.	JOB	Temporary Traffic Control	_____	_____
3.	3,631 SY	Edge Grind 8ft (2" to 0")	_____	_____
4.	818 SY	End Grind 20ft (2" to 0")	_____	_____
5.	196 SY	ADA Sidewalk Ramp	_____	_____
6.	1,224 TONS	Type 3 HMA ½" Dense (PG 64-28) 2- 2" Lifts	_____	_____
7.	16 EA	Water Valve Adjustment	_____	_____
8.	14 EA	Manhole Adjustment	_____	_____
9.	972 LF	Traffic Striping (Yellow and White)	_____	_____

BID AMOUNT: _____

SE Court Place (SE 11th Street to SE 14th Street) Overlay & Reconstruction

<u>Item No.</u>	<u>Approx. Quantity</u>	<u>Item with Unit Price Bid</u>	<u>Unit Price</u>	<u>Extended Total</u>
1.	JOB	Mobilization	_____	_____
2.	JOB	Temporary Traffic Control	_____	_____
3.	1,076 SY	Edge Grind 8ft (2" to 0")	_____	_____
4.	370 SY	End Grind 15ft (2" to 0")	_____	_____
5.	185 SY	Full Road Width Grind (2"-0")	_____	_____

<u>Item No.</u>	<u>Approx. Quantity</u>	<u>Item with Unit Price Bid</u>	<u>Unit Price</u>	<u>Extended Total</u>
6.	282 LF	Saw Cutting	_____	_____
7.	563 CY	Excavation in Place	_____	_____
8.	1,447 SY	Geotextile Fabric	_____	_____
9.	241 CY	2"-0" Base Rock in Place	_____	_____
10.	161 CY	3/4"-0" Base Rock in Place	_____	_____
11.	32 SY	ADA Sidewalk Ramp (Center Panel & Truncated Domes)	_____	_____
12.	377 TONS	Type 3 HMAC 1/2" Dense (PG 64-28) 2" Overlay	_____	_____
13.	325 TONS	Type 3 HMAC 1/2" Dense (PG 64-28) 2-2" Lifts	_____	_____
14.	24 SY	Asphalt Driveway (3" Thickness)	_____	_____
15.	5 EA	Water Valve Adjustments	_____	_____
16.	5 EA	Manhole Adjustment	_____	_____
17.	580 LF	Traffic Striping (Yellow and White)	_____	_____

BID AMOUNT: _____

SE Court Place (SE 11th Street to SE 14th Street) Bid Alternate

<u>Item No.</u>	<u>Approx. Quantity</u>	<u>Item with Unit Price Bid</u>	<u>Unit Price</u>	<u>Extended Total</u>
1.	219 LF	Curb & Gutter	_____	_____
2.	104 SY	Remove & Replace Sidewalk	_____	_____
3.	25 SY	Remove & Replace Concrete Driveway Approach	_____	_____

BID AMOUNT: _____

SW 28th Drive Reconstruction

<u>Item No.</u>	<u>Approx. Quantity</u>	<u>Item with Unit Price Bid</u>	<u>Unit Price</u>	<u>Extended Total</u>
1.	JOB	Mobilization	_____	_____
2.	JOB	Temporary Traffic Control	_____	_____
3.	102.5 LF	Saw Cutting	_____	_____
4.	318 CY	Excavation in Place	_____	_____
5.	758 SY	Geotextile Fabric	_____	_____
6.	126 CY	2"-0" Base Rock in Place	_____	_____
7.	84 CY	3/4"-0" Base Rock in Place	_____	_____
8.	432.5 LF	Curb & Gutter	_____	_____
9.	141 SY	Install Sidewalk	_____	_____
10.	43 SY	Remove & Replace Driveway Approach	_____	_____
11.	170 TONS	Type 3 HMAC 1/2" Dense (PG 64-28) 2-2" Lifts	_____	_____
12.	2 EA	Manhole Adjustments (1 Sanitary & 1 Communication)	_____	_____
13.	2 EA	Water Valve Adjustments	_____	_____
14.	1 EA	Water Meter Box Adjustment	_____	_____
15.	1 EA	Curb Inlet Catch Basin, Installed	_____	_____
16.	40.2 LF	6" Ductile Iron Storm Pipe, Installed	_____	_____
17.	1 EA	Install City Supplied Curb Outlet	_____	_____

<u>Item No.</u>	<u>Approx. Quantity</u>	<u>Item with Unit Price Bid</u>	<u>Unit Price</u>	<u>Extended Total</u>
18.	JOB	Relocate & Rebuild Eco-block/Railroad Tie Retaining Wall/Landing	_____	_____
19.	6.5 CY	Restorative Landscaping (Bark Mulch)	_____	_____
20.	45 SY	Restorative Landscaping (Top Soil & Sod)	_____	_____
21.	12 CY	Restorative Landscaping (3/4"-0" Gravel)	_____	_____

BID AMOUNT: _____

SW Nye Avenue (SW 2nd Street to SE 3rd Drive)

<u>Item No.</u>	<u>Approx. Quantity</u>	<u>Item with Unit Price Bid</u>	<u>Unit Price</u>	<u>Extended Total</u>
1.	JOB	Mobilization	_____	_____
2.	JOB	Temporary Traffic Control	_____	_____
3.	324.5 LF	Saw Cutting	_____	_____
4.	4,455 CY	Excavation in Place	_____	_____
5.	10,025 SY	Geotextile Fabric	_____	_____
6.	2,227.5 CY	2"-0" Base Rock in Place	_____	_____
7.	1,114 CY	¾"-0" Base Rock in Place	_____	_____
8.	60 SY	ADA Sidewalk Ramp	_____	_____
9.	14 LF	Curb & Gutter	_____	_____
10.	6.4 SY	Remove & Replace Sidewalk	_____	_____
11.	2 SY	Remove & Replace Driveway Approach Wing (5" Concrete Thickness)	_____	_____

<u>Item No.</u>	<u>Approx. Quantity</u>	<u>Item with Unit Price Bid</u>	<u>Unit Price</u>	<u>Extended Total</u>
12.	2,255.5 TONS	Type 3 HMAC ½" Dense (PG 64-28) 2- 2" Lifts	_____	_____
13.	9 EA	Manhole Adjustment	_____	_____
14.	10 EA	Water Valve Adjustment	_____	_____
15.	4,110 LF	Traffic Striping (Yellow and White)	_____	_____

BID AMOUNT: _____

SE Goodwin Avenue (S Main Street to PCC) Overlay

<u>Item No.</u>	<u>Approx. Quantity</u>	<u>Item with Unit Price Bid</u>	<u>Unit Price</u>	<u>Extended Total</u>
1.	JOB	Mobilization	_____	_____
2.	JOB	Temporary Traffic Control	_____	_____
3.	810 LF	Saw Cutting	_____	_____
4.	2,185 SY	Full Street Width Grind (2"-0")	_____	_____
5.	592 LF	Curb & Gutter	_____	_____
6.	177 LF	Mountable Curb & Gutter	_____	_____
7.	92 LF	Valley Gutter	_____	_____
8.	11 SY	Install Residential Concrete Driveway Approach	_____	_____
9.	36 SY	Remove & Replace Residential Concrete Driveway Approach	_____	_____
10.	7 SY	Remove & Replace Concrete Walkway	_____	_____
11.	200 SY	Install Asphalt Driveway (4" Thickness)	_____	_____

<u>Item No.</u>	<u>Approx. Quantity</u>	<u>Item with Unit Price Bid</u>	<u>Unit Price</u>	<u>Extended Total</u>
12.	44 SY	Install Asphalt Driveway (3" Thickness)	_____	_____
13.	246 TONS	Type 3 HMA 1/2" Dense (PG 64-28)	_____	_____
14.	2 EA	Water Valve Adjustment	_____	_____
15.	4 EA	Manhole Adjustment	_____	_____
16.	24 CY	Restorative Landscaping (3/4"-0" Gravel)	_____	_____
17.	34 SY	Restorative Landscaping (2" Minus River Rock)	_____	_____
18.	38 SY	Restorative Landscaping (Top Soil & Sod)	_____	_____
19.	63 LF	Traffic Striping (White)	_____	_____

BID AMOUNT: _____

NW Ellis Avenue (NW 8th Street to NW 11th Street) Overlay

<u>Item No.</u>	<u>Approx. Quantity</u>	<u>Item with Unit Price Bid</u>	<u>Unit Price</u>	<u>Extended Total</u>
1.	JOB	Mobilization	_____	_____
2.	JOB	Temporary Traffic Control	_____	_____
3.	2,339.5 SY	Full Street Width Grind (0" to 4")	_____	_____
4.	137.5 SY	ADA Sidewalk Ramp	_____	_____
5.	97 LF	Curb & Gutter	_____	_____
6.	19 SY	Install Residential Concrete Driveway Approach	_____	_____
7.	7.5 SY	Remove & Replace Residential Concrete Driveway Approach	_____	_____

<u>Item No.</u>	<u>Approx. Quantity</u>	<u>Item with Unit Price Bid</u>	<u>Unit Price</u>	<u>Extended Total</u>
8.	29 SY	Install Asphalt Driveway (3" Thickness)	_____	_____
9.	263 TONS	Type 3 HMAC ½" Dense (PG 64-28)	_____	_____
10.	23 SY	Restorative Landscaping (Top soil & Sod)	_____	_____
11.	3 EA	Water Meter Adjustment	_____	_____
12.	3 EA	Manhole Adjustment	_____	_____

BID AMOUNT: _____

NW 14th Street (NW Carden Avenue to NW Despain Avenue) Overlay

<u>Item No.</u>	<u>Approx. Quantity</u>	<u>Item with Unit Price Bid</u>	<u>Unit Price</u>	<u>Extended Total</u>
1.	JOB	Mobilization	_____	_____
2.	JOB	Temporary Traffic Control	_____	_____
3.	440 SY	Edge Grind 8ft (2" to 0")	_____	_____
4.	161 SY	End Grind 15ft (2" to 0")	_____	_____
5.	28 SY	ADA Sidewalk Ramp	_____	_____
6.	132 TONS	Type 3 HMAC ½" Dense (PG 64-28)	_____	_____
7.	1 EA	Water Valve Adjustment	_____	_____
8.	2 EA	Manhole Adjustment	_____	_____

BID AMOUNT: _____

GRAND TOTAL BID AMOUNT: _____

It is agreed that if the Bidder is awarded the Contract for the work proposed herein, and shall fail or refuse to execute the Contract and furnish the specified Performance and Payment Bond within ten (10) days after the receipt of the Notification of Acceptance of his Bid Proposal, then, in that case, the bid security deposited herewith by the said Bidder, according to the conditions of the Invitation to Bid and Information for Bidders, shall be retained by the City of Pendleton, Oregon, in accordance with the terms of the Bond as specified in the Information for Bidders.

The Bidder has examined and carefully studied the Contract Documents, the other related data identified in the Contract Documents, and the following Addenda, receipt of all which is hereby acknowledged:

Addendum Number:

Addendum Date:

The name of the Bidder who is submitting this Proposal is _____

doing business at _____

(Street)

(City)

(State)

(Zip)

which is the address to which all communication concerned with this Proposal and with the Contract shall be sent.

The name of the principal officers of the corporation submitting this Proposal, of the partnership, or of all persons interested in this Proposal as principals are as follows:

Print Name

Print Name

Signature

Signature

Dated this _____ day of _____, 2022.

Signature of Bidder

Title

BID BOND

KNOW ALL MEN BY THESE PRESENTS, that we, the undersigned, _____
_____ as Surety, are hereby held and
firmly bound unto _____ as OWNER in the
penal sum of _____ for the payment of
which, well and truly to be made, we hereby jointly and severally bind ourselves, successors and
assigns.

Signed, this _____ day of _____, 2022.

The condition of the above obligation is such that whereas the Principal has submitted to the City of
Pendleton a certain BID, attached hereto and hereby made a part hereof to enter into a Contract in
writing for the **2022 City Streets Overlay & Reconstruction Project.**

NOW THEREFORE,

(A) If said BID shall be rejected, or

(B) If said BID is accepted and the Principal executes and delivers contract in the Form of Contract
attached hereto (properly completed in accordance with said BID) and furnishes a BOND for the
faithful performance of said Contract, and for the payment of all persons performing labor or
furnishing materials in connection therewith, and in all other respects perform the agreement
created by the Acceptance of said BID,

then this obligation shall be void, otherwise the same shall remain in force and effect; it being expressly
understood and agreed that the liability of the Surety for any and all claims hereunder shall, in no event,
exceed the penal amount of this obligation as herein stated.

The Surety, for value received, hereby stipulates and agrees that the obligations of said Surety and
its BOND shall be in no way impaired or affected by any extension of the time within which the Owner
may accept such BID; and said Surety does hereby waive notice of any such extension.

IN WITNESS WHEREOF, the Principal and the Surety have hereunto set their hands and seals, and such of them as are corporations have caused their corporate seals to be hereto affixed and these presents to be signed by their proper officers, the day and year first set forth above.

Principal L.S.

Surety

By: _____
Attorney-in-Fact

IMPORTANT -- Surety companies executing BONDS must appear on the Treasury Department's most current list (Circular 570 as amended) and be authorized to transact business in the state where the project is located.



STATE OF OREGON
STATUTORY PUBLIC WORKS BOND

Surety bond #: _____ CCB # (if applicable): _____

We, _____, as principal, and _____, a corporation qualified and authorized to do business in the State of Oregon, as surety, are held and firmly bound unto the State of Oregon for the use and benefit of the Oregon Bureau of Labor and Industries (BOLI) in the sum of thirty thousand dollars (\$30,000) lawful money of the United States of America to be paid as provided in ORS chapter 279C, as amended by Oregon Laws 2005, chapter 360, for which payment well and truly to be made, we bind ourselves, our heirs, personal representatives, successors and assigns, jointly and severally, firmly by this agreement.

WHEREAS, the above-named principal wishes to be eligible to work on public works project(s) subject to the provisions of ORS chapter 279C, as amended by Oregon Laws 2005, chapter 360, and is, therefore, required to obtain and file a statutory public works bond in the penal sum of \$30,000 with good and sufficient surety as required pursuant to the provisions of section 2, chapter 360, Oregon Laws 2005, conditioned as herein set forth.

NOW, THEREFORE, the conditions of the foregoing obligations are that if said principal with regard to all work done by the principal as a contractor or subcontractor on public works project(s), shall pay all claims ordered by BOLI against the principal to workers performing labor upon public works projects for unpaid wages determined to be due, in accordance with ORS chapter 279C, as amended by Oregon Laws 2005, chapter 360, and OAR Chapter 839, then this obligation shall be void; otherwise to remain in full force and effect.

This bond is for the exclusive purpose of payment of wage claims ordered by BOLI to workers performing labor upon public works projects in accordance with ORS chapter 279C, as amended by Oregon Laws 2005, chapter 360.

This bond shall be one continuing obligation, and the liability of the surety for the aggregate of any and all claims which may arise hereunder shall in no event exceed the amount of the penalty of this bond.

This bond shall become effective on the date it is executed by both the principal and surety and shall continuously remain in effect until depleted by claims paid under ORS chapter 279C, as amended by Oregon Laws 2005, chapter 360, unless the surety sooner cancels the bond. This bond may be cancelled by the surety and the surety be relieved of further liability for work performed on contracts entered after cancellation by giving 30 days' written notice to the principal, the Construction Contractors Board, and BOLI. Cancellation shall not limit the responsibility of the surety for the payment of claims ordered by BOLI relating to work performed during the work period of a contract entered into before cancellation of this bond.

IN WITNESS WHEREOF, the principal and surety execute this agreement. The surety fully authorizes its representatives in the State of Oregon to enter into this obligation.

SIGNED, SEALED AND DATED this _____ day of _____, 20 _____

Surety by:

Principal by:

(Seal)
Company Name

Name

Signature

Signature

Title (e.g. Attorney-in-Fact)

Title

Address

Address

City State Zip

City State Zip

**SEND BOND TO: Construction Contractors Board
PO Box 14140
Salem, OR 97309-5052
Telephone: (503) 378-4621**



Construction Contractors Board

PO Box 14140
Salem OR 97309-5052
Telephone: 503-378-4621
Fax: 503-373-2007
Web Address: www.oregon.gov/ccb

For CCB Use Only:

File No. _____

Non-Construction Company

Filing STATUTORY PUBLIC WORKS BOND with CCB

ORS 279C.836 requires that all public works contractors working on qualifying public works projects, with a contract price that exceeds \$100,000, file a \$30,000 public works bond with the Construction Contractors Board (CCB). This includes construction companies that are licensed and non-construction companies that are not required to be licensed with the CCB.

If you are already licensed with the CCB, you do not need to complete this form. Please send your \$30,000 public works bond directly to the CCB with your license number on it.

If you are a non-construction company that is NOT required to be licensed with the CCB, please complete this information below and submit it with your \$30,000 public works bond. This will be used to help the CCB properly store and display your information on-line.

Type of Business Entity:			
<input type="checkbox"/> Sole Proprietor	<input type="checkbox"/> Joint Venture	<input type="checkbox"/> Partnership	<input type="checkbox"/> Corporation
<input type="checkbox"/> LLC	<input type="checkbox"/> LP	<input type="checkbox"/> LLP	<input type="checkbox"/> Trust
Oregon Corporation Division Registry No. (if applicable) _____			
Name of Business Entity: _____			
Business Address: _____			
Telephone No: (_____) _____ Email: _____			
Type of Work This Company Performs: _____			

I certify that the aforementioned independent contracting business does not perform work subject to ORS 701 and is **NOT** required to be licensed with CCB.

_____	_____
Name of Individual Filling Out This Form (Please Print)	Title/Position (Please Print)
_____	_____
Signature	Date

Contract No. _____

CONTRACT FOR CONSTRUCTION

THIS CONTRACT, made and entered into this _____ day of _____, 2022, by and between the City of Pendleton, Oregon, a municipal corporation hereinafter called the "Owner" and _____ hereinafter called the "Contractor".

WITNESSETH:

Said Contractor, in consideration of the sum in the amount of \$ _____ to be paid him by the Owner and of the covenants and agreements herein contained, hereby agrees at his own proper cost and expense to do all the work and furnish all the materials, tools, and labor for the construction of **2022 City Streets Overlay & Reconstruction Project.**

Contract Documents shall be referred to as Invitation to Bid, Information for Bidders, Prequalification, Bid Proposal, Bid Bond, Statutory Public Works Bond, Contract, Assignment of Antitrust Rights, Non-Collusion Affidavit, Performance/Payment Bond, Certificate of Insurance, Special Conditions, IRS Form W-9, Special Specifications, Drawings, any Addenda and the contents of the latest revision of the Oregon Standards Specifications for Construction (ODOT/APWA), excluding Sections 00100 and 00745.95 and the City of Pendleton Standard Specifications, and are all hereby made a part of this Contract by specific reference as fully and completely as if the same were fully set forth herein.

In the consideration of the faithful performance of the work herein embraced, as set forth in these Contract Documents, and in accordance with the direction of the Public Works Director (PWD) and to his satisfaction to the extent provided in the Contract Documents, the Owner agrees to pay to the Contractor the amount bid as adjusted in accordance with the proposals as determined by the Contract Documents, or as otherwise herein provided, and based on the said Proposal made by the Contractor, and to make such payments in the manner and at the times provided in the Contract Documents.

The Contractor agrees to indemnify and save harmless the Owner from any and all defects appearing or developing in the workmanship or materials performed or furnished under this Contract for a period of one (1) year after the acceptance by the Owner.

It is agreed that the time limit for the completion of the Contract, based upon the Proposal, is **no later than August 26, 2022.**

In the event that the Contractor shall fail to complete the work within the time limit or the extended time limit agreed upon, as more particularly set forth in the Contract Documents, liquidated damages shall be computed at the rate of one percent (1%) per day of total cost of work not yet completed for each of the contract schedules (or streets), or \$500 per calendar day for each schedule, whichever is greater for all work not yet completed by the contract deadline or work progression timeline, whichever occurs first. Sundays and legal holidays excluded in determining days of default.

The Contractor shall not discriminate against any employee or applicant for employment because of sex, race, creed, color, or national origin.

IN WITNESS WHEREOF, we the parties hereto, each herewith subscribe the same this _____ day of _____, 2022.

CITY OF PENDLETON

By _____
John H. Turner, Mayor

By _____
A.F. Denton, City Recorder

(Contractor)

By _____
(Signature)

Title: _____

Approved as to Form: _____
Nancy Kerns, City Attorney

Contractor's Registration # _____

Contractor's Tax Identification # _____

ASSIGNMENT OF ANTITRUST RIGHTS

By entering into a contract, the Contractor, for consideration paid to the Contractor under the contract, does irrevocably assign to the City of Pendleton any claim for relief or cause of action which the Contractor now has or which may accrue to the Contractor in the future, including, at the City's option, the right to further assign any claim for relief or consideration and to control any such litigation on such claim for relief or counsel action, by reason of any violation of 15 USC 1-15 or ORS 646.725 or ORS 646.730, in connection with any goods or services provided to the Contractor by any person, which goods or services are used, in whole or in part, for the purpose of carrying out the Contractor's obligations under this contract.

In the event the Contractor hires subcontractors to perform any of the Contractor's duties under the contract, the Contractor shall require the subcontractor to irrevocably assign to the City of Pendleton, as a third party beneficiary any right, title or interest that has accrued or may accrue to the subcontractor by reason of any violation of 15 USC 1-15, ORS 646.725 or ORS 646.730, including, at the City's option, the rights to further assess any claim for relief or Counsel action and to control any litigation arising there under, in connection with any goods or services provided to the subcontractor's obligations as agreed to by the Contractor in pursuance of the completion of the contract.

In connection with this assignment, it is an express obligation of the Contractor that it will take no action which will in any way diminish the value of the rights conveyed or assigned hereunder to the City of Pendleton. It is an express obligation of the Contractor to advise the City of Pendleton of Oregon:

1. In advance, of its intention to commence any action on its own behalf regarding such claims for relief or causes of action;
2. Immediately upon becoming aware of the fact that an action has been commenced on its own behalf by some other person or persons, of the pendency of such action; and
3. The date on which it notified the obligator(s) of any such claims for relief or cause of action of the fact of its assignment to the City of Pendleton.

Furthermore, it is understood or agreed that in the event that any payment under any such claim is made to the Contractor, it shall promptly pay to the City of Pendleton its proportionate share thereof, if any, assigned to the State hereunder.

NON-COLLUSION AFFIDAVIT

- 1) This Non-Collusion Affidavit is material to any Contract awarded pursuant to the bid. According to the Oregon Public Contracts and Purchasing Laws, a public contracting agency may reject any or all bids upon the finding by the agency that it is in the public interest to do so (ORS 279.035). This public contracting agency finds that it is in the public interest to require the completion of this Affidavit by potential Contractors.
- 2) This Non-Collusion Affidavit must be executed by the member, officer, or employee of the Bidder who makes the final decision for price(s) and the amount(s) quoted in the bid.
- 3) Bid rigging and other efforts to restrain competition and the making of false sworn statements in connection with the submission of bids are unlawful and may be subject to criminal prosecution. The person who signs the Affidavit should examine it carefully before signing and assure themselves that each statement is true and accurate, making diligent inquiry, as necessary, of all other persons employed by or associated with the Bidder with responsibilities for the preparation, approval, or submission of the bid.
- 4) In the case of a bid submitted by joint venture, each party to the venture must be identified in the bid documents, and an Affidavit must be submitted separately on behalf of each party.
- 5) The term “complementary bid” as used in the Affidavit has the meaning commonly associated with that term in the bid process and includes the knowing submission of bids higher than the bid of another firm, any intentionally high or non-competitive bid, and any other form of bid submitted for the purpose of giving a false appearance of competition.
- 6) Failure to file an Affidavit in compliance with these instructions may result in disqualification of the bid.

STATE OF _____)
)
County of _____)

I state that I am _____,
Print/Type - Name Print/Type - Position Title with Firm/Company

representing _____
Print/Type - Name of Firm/Company

and that I am authorized to make this Affidavit on behalf of my Firm/Company, and its owners, directors, and/or officers. I am the person responsible in my Firm/Company for the price(s) and the amount(s) provided in this Proposal.

I state that:

- 1) The price(s) and the amount(s) provided in this bid have been arrived at independently and without consultation, communication, or agreement with any other Contractor, Bidder, or potential Bidder, except as disclosed on the attached appendix to this Non-Collusion Affidavit.
- 2) Neither the price(s) nor the amount(s) provided in this bid, and neither the approximate price(s) nor approximate amount(s) provided in this bid, have been disclosed to any other Firm/Company or person who is a Bidder or potential Bidder, and they will not be disclosed before the bid opening.
- 3) No attempt has been made or will be made to induce any Firm/Company or person to refrain from Bidding on this contract, or to submit a bid with price(s) and/or amount(s) higher than this bid, or submit any intentionally high or noncompetitive price(s) and/or amount(s) in a bid or other form of complementary bid.
- 4) The price(s) and/or amount(s) provided in this bid on behalf of my Firm/Company is made in good faith and not pursuant to any agreement or discussion with, or inducement from, any Firm/Company or person to submit a complementary or other non-competitive bid.
- 5) My Firm/Company, its affiliates, subsidiaries, officers, directors, and/or employees are not currently under investigation by a governmental agency. They have not in the last four years been convicted of or found liable for any act prohibited by State or Federal law in any jurisdiction, involving conspiracy or collusion with respect to Bidding on any public contract, except as described on the attached appendix to this Non-Collusion Affidavit.

I state that my Firm/Company understands and acknowledges that the representations are material and important and will be relied on by the City of Pendleton in awarding the Contract(s) for which this Bid is submitted.

I understand, and my Firm/Company understands, that any misstatement in this Affidavit is and shall be treated as fraudulent concealment from the City of Pendleton of the true facts relating to the submission of the Bid for this Contract(s).

Signature - Name

This instrument was acknowledged before me this _____ day of _____, 2022.

Notary Public for _____

My Commission Expires: _____

PERFORMANCE/PAYMENT BOND

KNOW ALL MEN BY THESE PRESENTS, that we, _____

(The official name, form of organization, and address of the Contractor, and, if partnership, name of partners.)

as Principal, and _____
(Name and Address of the Surety)

_____, a corporation, duly authorized to do a general surety business in the State of Oregon as Surety, are jointly and severally held and bound unto City of Pendleton in the sum of ____

(the basic contract price, in words and figures)

for the payment of which we jointly and severally bind ourselves, our heirs, executors, successors, and assigns, firmly by these presents.

THE CONDITIONS OF THIS BOND ARE SUCH THAT

WHEREAS _____ the Principal herein on the ____ day of _____, 2022, entered into a Contract with the City of Pendleton, the obligee herein, which Contract consists of:

Invitation to Bid, Information for Bidders, Prequalification, Bid Proposal, Bid Bond, Statutory Public Works Bond, Contract, Assignment of Antitrust Rights, Non-Collusion Affidavit, Performance/Payment Bond, Certificate of Insurance, Special Conditions, IRS Form W-9, Special Specifications, Drawings, any Addenda, Oregon Standard Specifications for Construction (ODOT/APWA) latest revision, excluding Sections 00100 and 00745.95, and the City of Pendleton Standard Specifications

All as hereto attached and made a part hereof, whereby said Principal undertakes to do all labor, furnish all plant and equipment, and furnish all material in accordance with all the terms and conditions set forth in said Contract Documents; and promptly to make payment for all labor, services, and material and pay sums due the City of Pendleton and the United States required to be paid by employers and to save harmless the obligee from any claims for damages or injury to property or persons arising by reason of said work, as set out more fully in said Contract Documents; and to do and perform all things in said Contract Documents required, in the time and manner and under the terms and conditions therein set forth; and in conformity with all laws, state and national.

NOW THEREFORE, if said Principal herein shall promptly pay all persons, furnishing labor, services, material or insurance to said Principal, or to his subcontractors, or to their assigns, on or about said work; and shall save harmless the Obligee, its officers and agents, from all claims therefore, or from any claim for damages of injury to property or persons arising by reason of said work; and shall in the time and manner, and under the terms and conditions prescribed, will and faithfully do, perform and furnish all material and things as by them in said contract undertaken, and as by law, state, and federal prescribed, then this obligation shall be void, but otherwise it shall remain in full force and effect.

PROVIDED, HOWEVER, that this bond is subject to the following further conditions:

(a) All material, workmen, and all persons who shall supply such laborers, mechanics or subcontractors with material, supplies, or provisions for carrying on such work shall have a direct right of action against the Principal and Surety on this bond, second only to the right of the Obligee under this bond, which right of action shall be asserted in proceedings instituted in the appropriate court of the State of Oregon, and insofar as permitted by the laws of Oregon, such right of action shall be asserted in a proceeding instituted in the name of the Obligee to the use and benefit of the person, firm or corporation instituting such action and of all persons, firms, or corporations having claims hereunder shall have the right to be made a party to such proceeding (but not later than six months after the complete performance of said contract and final settlement and judgment rendered thereon).

(b) In no event shall the Surety be liable for a greater sum than the amount of this bond, or subject to any suit, action, or proceeding thereon that is instituted later than twelve (12) months after the complete performance of said contract and final settlement thereof.

(c) Said Surety, for value received, hereby stipulates and agrees that no change, extension of time, alteration, or addition to the terms of the contract or to the work to be performed thereunder or the specifications and accompanying the same shall in any way affect its obligations on this bond. It does hereby waive notice of such change, extension of time, alteration, or addition to the terms of the contract or to the work or to the specifications.

IN WITNESS WHEREOF, the parties hereto have caused this Bond to be executed in _____
this _____ day of _____, 2022.

_____(SEAL)

_____(SEAL)

_____(SEAL)

(Principal)

WITNESSES:

_____(SEAL)

_____(SEAL)

COUNTERSIGNED:

BY: _____

(Resident Agent)

ISSUE DATE _____

CERTIFICATE OF INSURANCE

This is to certify to the CITY OF PENDLETON that a CERTIFICATE OF INSURANCE is issued co-insuring the City of Pendleton as described below and that the insurer agrees that it shall notify the City in writing, of material change, or any expiration or of any cancellation of the below described policies not less than thirty (30) days prior to such change, expiration, or cancellation may become effective and that such notice shall be made by certified mail, return receipt requested, to the City of Pendleton at the following address: 500 S. W. Dorion Avenue, Pendleton, Oregon 97801.

Insured _____ COMPANIES AFFORDING COVERAGE
Company Letter A _____
Company Letter B _____
Company Letter C _____
Company Letter D _____
Company Letter E _____

COVERAGES

THIS IS TO CERTIFY THAT POLICIES OF INSURANCE LISTED BELOW HAVE BEEN ISSUED TO THE INSURED NAMED ABOVE FOR THE POLICY PERIOD INDICATED, THE INSURANCE AFFORDED BY THE POLICY DESCRIBED HEREIN IS SUBJECT TO ALL THE TERMS, EXCLUSIONS, AND CONDITIONS OF SUCH POLICIES EXCEPT WHERE, A CONTRACT BETWEEN THE INSURED AND THE CITY OF PENDLETON REQUIRES OTHERWISE.

TYPE OF INSURANCE (Check One) POLICY NUMBER POLICY EFFECTIVE DATE POLICY EXPIRATION DATE LIABILITY LIMITS IN THOUSANDS EACH OCCURRENCE AGGREGATE

Claims Made
Occurrence

GENERAL LIABILITY
COMPREHENSIVE FORM
PREMISES/OPERATIONS
UNDERGROUND
EXPLOSION & COLLAPSE
PRODUCTS/COMPLETED OPERATIONS
CONTRACTUAL
INDEPENDENT CONTRACTORS
BROAD FORM PROPERTY DAMAGE
PERSONAL INJURY
BODILY INJURY
PROPERTY DAMAGE
BI & PD COMBINED
PERSONAL INJ.

AUTOMOBILE LIABILITY
ANY AUTO
ALL OWNED AUTOS (PRIV. PASS.)
ALL OWNED AUTOS (OTHER THAN PRIV. PASS)
HIRED AUTOS
NON-OWNED AUTOS
GARAGE LIABILITY
BODILY INJURY (PER PERSON)
BODILY INJURY (PER ACCIDENT)
PROPERTY DAMAGE
BI & PD COMBINED

EXCESS LIABILITY
UMBRELLA FORM
OTHER THAN UMBRELLA FORM
BI & PD COMBINED

WORKER'S COMPENSATION AND EMPLOYERS' LIABILITY
STATUTORY
(each accident)
(disease policy limit)
(disease-each employee)

OTHER

DESCRIPTION OF OPERATIONS/LOCATIONS/VEHICLES/SPECIAL ITEMS

SPECIAL INSTRUCTIONS INDICATE WITH RESPECT TO EACH OF THE GENERAL CATEGORIES OF INSURANCE, IE. GENERAL LIABILITY, AUTO LIABILITY, EXCESS LIABILITY AND THE LIKE, WHETHER OR NOT THEY COVER THE BOXES ABOVE. SPECIFICALLY, THE CITY WANTS TO KNOW WHETHER BY CHECKING ONE OF THE BROAD COVERAGES ALL THE COVERAGES LISTED ARE ALSO INCLUDED. IN ADDITION, WITH RESPECT TO AGGREGATE LIMITS PLEASE INDICATE WHETHER THE AGGREGATES ARE FOR ONE OCCURRENCE OR AGGREGATE DURING THE LIFE OF THE POLICY WITH RESPECT TO EACH.

CERTIFICATE HOLDER CANCELLATION

This is to certify to the CITY OF PENDLETON that a CERTIFICATE OF INSURANCE is issued co-insuring the City of Pendleton as described below and that the insurer agrees that it shall notify the City in writing, of material change, of any expiration, of any cancellation of the below described policies not less than thirty (30) days prior to such change, expiration, or cancellation may become effective and that such notice shall be made by certified mail, return receipt requested, to the City of Pendleton at the following address: 500 SW Dorion Avenue, Pendleton, OR 97801.

AUTHORIZED REPRESENTATIVE _____

SPECIAL CONDITIONS

1. The Contractor shall make payment promptly, as due, to all persons supplying to such Contractor labor or materials for the prosecution of the work provided in the Contract.
2. The Contractor shall provide workers' compensation insurance coverage for all individuals, others than those exempt under ORS 656.027, who perform labor under the Contract before labor under the Contract commences. Contractor shall pay all contributions or amounts due for Workers' Compensation coverage from the Contractor incurred in the performance of the Contract.

A copy of each insurance policy, or certificate thereof, issued by a responsible and solvent insurance corporation or association authorized to issue such policy or policies under the laws of the State of Oregon shall be delivered to the City within a reasonable period of time after the same is issued by the company or companies or associations issuing such policy or policies. All said policies or certificates shall provide for a minimum of thirty (30) days notice to the City in the event of cancellation or material change in the terms.
3. The Contractor will not permit any lien or claim to be filed or prosecuted against the City on account of any material or labor furnished to the Contractor.
4. The Contractor will pay to the Oregon Department of Revenue all sums withheld from employees pursuant to Oregon Statutes.
5. The Contractor shall demonstrate that an employee drug testing program is in place.
6. If the Contractor fails, neglects, or refuses to make prompt payment of any claim for labor or services furnished to the Contractor or a subcontractor by any person in connection with this Contract as such claim shall become due, the proper officer or officers representing the City may pay such claim to the person furnishing the labor or service and charge the amount of the payment against funds due or to become due to the Contractor by reason of this Contract. The payment of a claim in this manner authorized by this paragraph shall not relieve the Contractor or the Contractor's surety from obligation with respect to any unpaid claim. {ORS 279C.515; OAR 839-025-0020(2)(a)}
7. **The Contractor shall, within two (2) working hours after the advertised bid closing date and time, notify the Community Development Director in writing of the names of the first-tier subcontractors on the disclosure form attached to the end of these Special Conditions. If no subcontractors need to be disclosed, enter "NONE" on the form and submit it. Submission of the first-tier subcontractors disclosure form only applies to public contracts for public improvements with a contract value of more than \$100,000 (ORS 279C.370).**
8. In addition to required performance bonds which may be used for unpaid wages, all contractors, subcontractors and non-construction companies who work on public works projects, with a contract price that exceeds \$100,000, subject to the Prevailing Wage Rate law, shall file a \$30,000 Public Works Bond with the Construction Contractor's Board (CCB) before starting work on the project, unless exempt, to be used exclusively for unpaid wages determined to be due by BOLI {ORS 279C.830 and ORS 279C.836}. **(See forms included in Section 5.00)**

This bond applies to ALL CCB licensed and non-CCB licensed subcontractors. Contractors must include in every subcontract a provision requiring the subcontractor to have a Public Works Bond filed with the CCB and must verify that subcontractors have filed a Public Works Bond before permitting subcontractor to start work on a project, unless exempt. For more information regarding this requirement, contact the Construction Contractors Board at (503) 378-4621.
9. If the Contractor or a first-tier subcontractor fails, neglects or refuses to make payment to a person furnishing labor or materials in connection with this Contract within thirty (30) days after receipt of payment from the public contracting agency or a contractor, the Contractor or first-tier subcontractor shall owe the

person the amount due plus interest charges commencing at the end of the 10-day period that payment is due under ORS 279C.580 (4) and ending upon final payment, unless payment is subject to a good faith dispute as defined in ORS 279C.580. The rate of interest charged to the Contractor or first-tier subcontractor on the amount due is nine percent per annum. The amount of interest may not be waived.

10. If the Contractor or a subcontractor fails, neglects or refuses to make payment to a person furnishing labor or materials in connection with the public improvement contract, the person may file a complaint with the Construction Contractors Board, unless payment is subject to a good faith dispute as defined in ORS 279C.580. Every contract related to this Contract shall contain a clause setting forth this requirement.

11. If requested in writing by a first-tier subcontractor, the Contractor, within ten (10) calendar days after receiving the request, shall send to the first-tier subcontractor a copy of that portion of any invoice, request for payment submitted to the public contracting agency or pay document provided by the public contracting agency to the Contractor specifically related to any labor or materials supplied by the first-tier subcontractor.

12. Except where the Contractor is a party to a collective bargaining agreement in effect with a labor organization, no person shall be employed for more than 10 hours in any one day, or 40 hours in any one week, except in cases of necessity, emergency, or where the public policy absolutely requires it, and in such cases, the employee shall be paid at least time and a half pay:

- a. For all overtime in excess of eight hours a day or 40 hours in any one week when the work week is five consecutive days, Monday through Friday except for individuals under this Contract who are excluded under ORS 653.010 to 653.261 or under 29 U.S.C. sections 201 to 209 from receiving overtime; or
- b. For all overtime in excess of 10 hours a day or 40 hours in any one week when the work week is four consecutive days, Monday through Friday; except for individuals under this Contract who are excluded under ORS 653.010 to 653.261 or under 29 U.S.C. sections 201 to 209 from receiving overtime; and
- c. For all work performed on Saturday and on the following legal holidays:
 - (i) Each Sunday.
 - (ii) New Year's Day on January 1.
 - (iii) Memorial Day on the last Monday in May.
 - (iv) Independence Day on July 4.
 - (v) Labor Day on the first Monday in September.
 - (vi) Thanksgiving Day on the fourth Thursday in November.
 - (vii) Christmas Day on December 25.
- d. Each time a holiday listed above falls on Sunday, the succeeding Monday shall be recognized as a legal holiday. Each time a holiday listed above falls on Saturday, the preceding Friday shall be recognized as a legal holiday. (ORS 279C.540)
- e. The Contractor must give notice to employees who work on a public contract in writing, either at the time of hire or before commencement of work on the Contract, or by posting a notice in a location frequented by employees, of the number of hours per day and days per week that the employees may be required to work. (ORS 279C.520)

13. Contractor must promptly pay for an employee's medical services Contractor has agreed to pay. (ORS 279C.530)

14. Each worker in each trade or occupation employed in the performance of the Contract either by the Contractor, subcontractor or other person doing or contracting to do or contracting for the whole or any part of the work on the Contract, shall be paid not less than the applicable prevailing rate of wage as required by ORS Chapter 279C. **The existing prevailing wage rates in effect on January 1, 2022, including any amendments, are as published by the Oregon Bureau of Labor and Industries. Copies of the existing prevailing wages are available online at www.oregon.gov/boli.** If a project begins with a total project cost under \$50,000, but change orders increase the project cost to more than \$50,000, the entire project will be subject to the prevailing wage rate law, including all work already performed on the project. {OAR 839-025-0100(1)(a)}

15. The Contractor shall promptly, as due, make payment to any person, co-partnership, association or corporation, furnishing medical, surgical and hospital care or other needed care and attention, incident to sickness or injury, to the employees of such Contractor, of all sums which the Contractor agrees to pay for such services and all moneys and sums which the Contractor collected or deducted from wages of employees pursuant to any law, contract, or agreement for the purpose of providing or pay for such service.

16. Any and all employees of Contractor or his contractors while engaged or performing any work or services required by him under this agreement shall be considered his employees only and not employees of the City and any claims that may arise under the Workers' Compensation Act on behalf of the said employees while so engaged in any and all claims made by third parties as a consequence of any act or omission on the part of him or his employees while so engaged on any of the work or services provided to be rendered herein shall be the sole obligation responsibility of Contractor and/or his contractors. The parties to this agreement recognize that Contractor and his employees, officers, agents and subcontractors are providing professional services as independent contractors and are not providing services as employees of the City and are therefore not entitled to the benefits provided by the City to his employees, including but not limited to Workers' Compensation benefits, group health insurance, social security, pension plans, or any other benefit accruing to City's employees. Contractor hereby agrees to hold the City harmless from, and shall process and defend at his own expense, all claims, demands, or suits of whatever nature, brought against him arising from his performance under this agreement. Contractor shall advise his officers, agents, employees and subcontractors of this provision.

17. The Contractor shall keep himself informed and at all times comply with any ordinance, laws, and regulations dealing with the preservation of environmental pollution and the preservation of natural resources that may be affected in the performance of the Contract. The following are a list of agencies that may have enacted ordinances or regulations dealing with the preservation and environmental pollution and the preservation of natural resources:

Federal Agencies:

Agriculture, Department of
Forest Service
Soil Conservation Service
Defense, Department of
Army Corps of Engineers
Energy, Department of
Federal Energy Regulatory Commission
Environmental Protection Agency
Health and Human Services, Department of
Housing and Urban Development,
Department of Solar Energy and Energy
Conservation Bank
Interior, Department of
Bureau of Land Management
Bureau of Indian Affairs
Bureau of Mines
Bureau of Reclamation
Geological Survey
Mineral Management Service
U.S. Fish and Wildlife Service
Labor, Department of
Occupational Safety and Health Administration
Mine Safety and Health Administration
Transportation, Department of
Coast Guard
Water Resources Council

State Agencies:

Administrative Services, Department of
Dept of Agriculture
Department of Consumer & Business Services,
State of Oregon
Occupational Safety & Health Division
Environmental Quality, Department of
Fish and Wildlife, Department of
Forestry, Department of
Geology and Mineral Industries, Department of
Health Division
Historic Preservation Office
Human Resources, Department of
Land Conservation and Development Commission
Parks and Recreation, Department of
Soil and Water Conservation Commission
State Engineer
State Land Board (Lands, Division of State)
Transportation, Department of
Water Resources Department

Local Agencies:

City of Pendleton City Council
Umatilla County Commissioners
Board of Port of Umatilla
Fire Protection Districts
City of Pendleton Planning Commission
Umatilla County Planning Commission
Confederated Tribes of the Umatilla Indian
Reservation

18. Liability and Indemnity:

- a. Indemnification. Contractor shall indemnify, hold harmless and defend City and its officers, agents and employees from, and reimburse City for, any cost, claim, loss, or liability suffered directly or from a third-party claim arising out of or related to any negligent activity of Contractor in the execution of this Contract. City shall have no liability to Contractor for any injury, loss, or damage caused by Contractor or third parties.
- b. Public Liability and Property Damage Insurance. Before beginning execution of the Contract, Contractor shall maintain public liability insurance against death or injury to person, or damage to property, during the life of this Contract at Contractor's cost; said insurance shall be in such form so as to protect both Contractor and City from all claims expressed or implied as above provided, and in the following amounts:
 - 1) Public Liability Insurance not less than \$1,000,000 for injuries to any one person, including accidental death and not less than \$1,000,000 for any one accident.
 - 2) Property Damage Insurance not less than \$1,000,000 for any one accident.

The Contractor's Public Liability and Property Damage Insurance shall adequately provide the primary coverage on all claims arising out of the performance of the Contract. Such insurance shall cover all risks arising directly or indirectly out of Contractor's activities. Such insurance shall protect Contractor against the claims on account of the obligations assumed by Contractor under this Contract and shall name City and its officers, agents and employees as additional insured.

The above-mentioned proof shall be in the form of a copy of the policy and all appropriate riders with the City being named as a co-insured on all policies and provide for thirty (30) days written notice of any change or cancellation to City before Contractor begins execution of the Contract.

19. No bid for construction will be received or considered by the City unless the bidder is registered with the Construction Contractors Board as required by ORS Chapter 701 or the State Landscape Contractors Board as required by ORS 672.530. In addition, the contractor and subcontractors must obtain a City of Pendleton Business License as follows:

- a. Any contractor or subcontractor engaged in any activity for which registration with the Oregon Construction Contractors Board is required pursuant to Oregon Revised Statutes, Chapter 701, must obtain a City of Pendleton Business License or comply with the alternative in paragraph 19.c. below.
- b. The Contractor or any subcontractor engaged in any activity for which registration with the Oregon Construction Contractors Board is required pursuant to Oregon Revised Statutes, Chapter 701, must include, as part of the application for a City of Pendleton business license, a copy of a current certificate of registration issued by the Oregon Construction Contractors Board.
- c. A prime contractor engaged in a construction project may obtain a Construction Project License as an alternative to obtaining a City of Pendleton Business License for each subcontractor engaged in the Construction Project. The Construction Project License is in lieu of a Business License for subcontractors only and is in addition to the Business License of the prime contractor. The application for a Construction Project License must contain, among other items, a signed statement by the prime contractor and each subcontractor engaged in the Construction Project that each signatory is registered under the provisions of this Oregon Revised Statutes, Chapter 701, and stating that the registration is in full force and effect. For the prime contractor and each subcontractor, a copy of a current certificate of registration issued by the Oregon Construction Contractors Board is also required.

20. The Oregon Government Standards and Practices laws may apply to Contractor. ORS 244.040(1)(a) prohibits any government officer, employee, or agent from using the governmental relationship to obtain a financial gain or avoid a financial detriment that would not otherwise be available but for the governmental relationship. For further information on this matter contact the Oregon Government Standards and Practices Commission; 100 High Street SE, Suite 220; Salem, Oregon 97310; phone 503/378-5105.

21. Contractor certifies that:

- a. Contractor is free from direction and control over the means and manner of providing the labor or services, subject only to the right of City to specify the desired results;
- b. Contractor is responsible for obtaining all assumed business registrations or professional occupational licenses required by state law or local governmental ordinances;
- c. Contractor furnishes the tools or equipment necessary for performance of the contracted labor or services;
- d. Contractor has the authority to hire and fire employees to perform the labor or services;
- e. Payment for the labor or services is made upon completion of the performance of specific portions of the project or is made on the basis of a periodic retainer;
- f. Contractor is registered under ORS chapter 701 (Construction Contractors), if Contractor provides labor or services for which such registration is required;
- g. Federal and state income tax returns in the name of the business or a business Schedule C or farm Schedule F as part of the personal income tax return were filed for the previous year if the contractor performed labor or services as an independent contractor in the previous year; and
- h. Contractor represents to the public that the Contractor is an independently established business. Except where Contractor files a Schedule F as part of the personal income tax return and the Contractor performs farm labor or services that are reportable on Schedule C, Contractor is considered to be engaged in an independently established business when four or more of the following circumstances exist:

[Initial those that apply]

- i. ___ The labor or services are primarily carried out at a location that is separate from the residence of Contractor or are primarily carried out in a specific portion of the residence, which portion is set aside as the location of the business;
- ii. ___ Commercial advertising or business cards as is customary in operating similar businesses are purchased for the business, or the Contractor has a trade association membership;
- iii. ___ Telephone listing and service are used for the business that is separate from the personal residence listing and service used by Contractor;
- iv. ___ Labor or services are performed only pursuant to written Contracts;
- v. ___ Labor or services are performed for two or more different persons within a period of one year; or
- vi. ___ Contractor assumes financial responsibility for defective workmanship or for service not provided as evidenced by the ownership of performance bonds, warranties, errors and omission insurance or liability insurance relating to the labor or services provided.

22. If any action is instituted in connection with any claim or controversy arising out of this agreement, attorney fees may not be awarded by the court of competent jurisdiction and each party shall bear its own expenses of such action.

23. This agreement and the parties rights under it shall be construed and regulated by the laws of the State of Oregon and venue for any dispute hereunder shall lie in Pendleton, Umatilla County, Oregon.

24. Normal working hours are Monday through Friday, 7:00 am to 5:00 pm. Work may extend beyond this time period with prior written permission from the City. The Contractor shall notify the City forty-eight (48) hours in advance of time work will be performed on Saturdays, Sundays or Holidays or other than normal working hours.

Per Ordinance No. 2287, no work that produces dust or flying debris shall be performed or equipment utilized that produces noise of sufficient volume to disturb the sleep or repose of occupants of neighboring property between the hours of 6:00 pm and 7:00 am without express written permission from the City.

25. The Contractor shall plan, coordinate and be responsible for all construction work and proceed with minimum interference to the operation of any existing facilities or other construction work. Prior to starting the construction, confer with the City to develop an approved construction schedule, which will permit the

facility to function as normal as practical during the construction. If it becomes necessary to do certain parts of the construction outside normal working hours, or change/modify sequence of activities in order to avoid undesirable conditions, it shall be the obligation of the Contractor to do this work at such a time at no additional cost to the City.

26. The Contractor shall maintain proper and required construction related impact controls, including controls for such impact as noise, dust, erosion and hours of operation.

27. The Contractor shall provide and receive written approval from the City of Pendleton a payment schedule prior to construction.

28. All existing features including, but not limited to, roadways, driveways/easements, structures, lots, curbs, sidewalks, fences, walls, plantings, ditches, mailboxes, signs, irrigation, piping and utilities disturbed during construction shall be restored to "AS GOOD or BETTER" than original condition unless otherwise specified in the plans/specifications. If a utility is damaged during construction, the Contractor shall contact owner of the utility for inspection of damage prior to repairs. Contractor shall repair all utility services damaged during construction, and such repair shall be considered incidental.

If an irrigation system is impacted in any way, Contractor will cap affected area and notify property owner immediately (within the hour). If related to form work, once forms are pulled, Contractor will re-establish fully functioning irrigation system "AS GOOD or BETTER" within 24-hours of forms being pulled and notify property owner of repair by the close of the work day.

If plantings are affected in any way, Contractor will notify the property owner immediately (within the hour). If planting is compromised or dies, Contractor will re-establish plantings within 48 hours and/or a damaged irrigation system becoming fully functioning.

29. Recovery of Costs:

As work on the Contract progresses, the City shall upon request, inform the Contractor of all accrued costs. If punch list items are not completed after the 12-month period following substantial completion, the City will retain the remaining retainage and consider the Contract closed. The City will complete the punch list items and any cost above the remaining retainage withheld will be sought by placing a lien against the Contractor's bond.

30. Final Payment:

Upon completion of the work, Contractor shall notify City in writing that they have completed their part of the Contract and shall request Final Payment. Final Payment or any part of the retained percentage will be withheld upon the option of the City until the Contractor submits to the City an Affidavit Certifying Contractor Payment for Labor, Services and Materials, Compliance with Labor Provisions and Contractor's Acceptance of Final Payment. (see Affidavit attached to end of this Section)

31. Oregon's Reciprocal Preference Law:

ORS 279A.120 requires public contracting agencies, in determining the lowest responsible bidder, to add a percent increase to each out-of-state bidder's bid price which is equal to the percent of preference given to local bidders in the bidder's home state. That is, if the low bidder is from a state that grants a 10 percent preference to its own in-state bidders, the Oregon agency must add 10 percent to that bidder's price when evaluating the bid.

ORS 279A.120(2) states: For the purposes of awarding a public contract, a contracting agency shall:

- (a) Give preference to goods or services that have been manufactured or produced in this state if price, fitness, availability and quality are otherwise equal; and
- (b) Add a percent increase to the bid of a nonresident bidder equal to the percent, if any, of the preference given to the bidder in the state in which the bidder resides.

The Oregon Department of Administrative Services (DAS) has gathered information on preference laws of all states. For more information please visit: <https://www.oregon.gov/DAS/Procurement/Pages/Index.aspx>.

32. In-State Tie-Bid Awards:

All state and local contracting agencies shall give preference to in-state offerors if their offers are the same as nonresident offerors.

33. Nonresident Bidders:

ORS 279A.120(3) states: "When a public contract is awarded to a nonresident bidder and the contract price exceeds \$10,000, the bidder shall promptly report to the Department of Revenue (DOR) on forms to be provided by the department the total contract price, terms of payment, length of contract and such other information as the department may require before the bidder may receive final payment on the public contract. The contracting agency shall satisfy itself that the requirement of this subsection has been complied with before the contracting agency issues a final payment on a public contract." (See form attached to the end of these Special Conditions)

To view ORS 279A.120, visit: www.oregonlegislature.gov

For information about DOR requirements, visit: www.oregon.gov/DOR.

34. Damage of existing structure:

When the existing structure or facility, which is intended to remain, is damaged by the Contractor during demolition or construction, the Contractor shall promptly repair and replace the damaged portion of the facility at no cost to the City.

35. Street closures and notifications:

Streets may be closed as approved by City of Pendleton on a case-by-case basis. Contractor will be responsible for all necessary signing (**lettering should be easily legible from a vehicle and be at least 3"-4" in size**) and public notification and will give a minimum forty-eight (48) hours advance notification to the City and all residents and businesses along a street scheduled for reconstruction. Overall schedule must be submitted to and approved by City five (5) days prior to commencing work. City will publish schedule with local media to help with public notification

Public notification by the Contractor must also be sent to the following:

- Mid Columbia Bus Company
- Kayak Public Transit
- Let 'er Bus Transit
- Umatilla County Dispatch
- Police Chief
- Fire Chief

Contact information for the above will be provided by the City at the pre-construction meeting.

DATED: _____, 2022

Contractor: _____

By: _____

**CITY OF PENDLETON
FIRST-TIER SUBCONTRACTOR DISCLOSURE FORM**

Bids which are submitted by Bid Closing, but for which a required disclosure submittal has not been made by the specified Disclosure Deadline, are not responsive and shall not be considered for Contract award.

AGENCY SUPPLIED INFORMATION:

Project Name: 2022 City Streets Overlay & Reconstruction Project
 Bid Closing Date: April 7, 2022 Time: 2:30 pm
 Disclosure Deadline Date: April 7, 2022 Time: 4:30 pm

THIS DISCLOSURE FORM MUST BE SUBMITTED to the City of Pendleton at the location specified and in accordance with the date and time in the Advertisement for Bids. A separate form must be submitted for each Schedule. If necessary, use additional forms to satisfy the Disclosure requirements.

The contracting agency will insert "N/A" if the contract value is not anticipated to exceed \$100,000, otherwise, this form must be submitted either with the bid or within two (2) working hours after the advertised bid closing date and time; but no later than the Disclosure Deadline stated above.

List below the NAME, ADDRESS, DOLLAR VALUE, CONSTRUCTION CONTRACTOR BOARD (CCB) NUMBER, CONTACT NAME and TELEPHONE NUMBER of each Subcontractor that will be furnishing labor and/or materials that are required to be disclosed in accordance with ORS 279C.370.

ENTER "NONE" IF THERE ARE NO SUBCONTRACTORS THAT NEED TO BE DISCLOSED.
 (Attach additional sheets if needed)

<u>NAME/ADDRESS OF SUBCONTRACTORS</u>	<u>\$ VALUE/CCB #</u>	<u>CONTACT NAME/PHONE #</u>
1) _____ _____	\$ _____ CCB# _____	_____
2) _____ _____	\$ _____ CCB# _____	_____
3) _____ _____	\$ _____ CCB# _____	_____

The above listed first-tier subcontractor(s) are providing labor and/or materials with a Contract value equal to or greater than:

- a) 5% of the total project amount proposed or \$15,000, whichever is greater; or
- b) \$350,000, regardless of the percentage of the total project amount proposed.

Disclosure submitted by: _____
Signature – Bidder Name

Contact Name: _____
Print/type – Bidder Name Phone Number

Unless otherwise stated in the original solicitation, this document shall not be faxed. It is the responsibility of the Bidder to separately submit this Disclosure Form and any additional sheets with the Project Schedule and Name clearly marked in accordance with the date and time in the Advertisement for Bids.

DATED this _____ day of _____, 20__.

Contractor's Name

Print Name and Title

Signature

State of _____)

)

County of _____)

On the _____ day of _____, 20__, personally appeared _____
as _____ of _____, Contractor,
who acknowledged this instrument to be his/her voluntary act and deed.

(SEAL)

Notary Public for _____

My Commission Expires: _____

Form OR-NRB

Page 1 of 1, 150-800-020 (Rev. 03-17) Oregon Department of Revenue

Office use only
Date received

Oregon Nonresident Bidder Form

Submit original form—do not submit photocopy.

Oregon Revised Statute (ORS) 279A.120 states that when a public contract is awarded to a nonresident bidder and the contract price is more than \$10,000, the bidder must report certain information to the Oregon Department of Revenue before the bidder can receive final payment on the contract. To view ORS 279A.120, visit www.oregonlegislature.gov.

Using one of the options below, you must submit this completed form before we can make your final payment.

A. Bidder information

Company name		Federal ID number
Company contact name		Oregon business ID number
Street/mailling address		Telephone () -
City, state, ZIP	Email	

B. Contract information

Contracting agency name		
Terms of payment	Total contract price \$	
Brief description of services provided		
Will the work or services provided, at any time, require a physical presence in Oregon? <input type="checkbox"/> Yes <input type="checkbox"/> No		
Contract number	Start date of contract / /	Contract expiration date / /
Agency contact		

C. Submitting this form

Please submit this form one of these ways:

Mail	Fax	Email
Oregon Department of Revenue Financial Services Unit 955 Center Street NE, Room 461 Salem OR 97301	503-945-8382	dor.procurement@state.or.us <i>(You must have Acrobat Standard or Professional to use this option)</i>

Name of person signing for business _____ Title _____

Signature of person signing for business _____ Date _____

Request for Taxpayer Identification Number and Certification

Give Form to the requester. Do not send to the IRS.

▶ Go to www.irs.gov/FormW9 for instructions and the latest information.

1 Name (as shown on your income tax return). Name is required on this line; do not leave this line blank.

2 Business name/disregarded entity name, if different from above

3 Check appropriate box for federal tax classification of the person whose name is entered on line 1. Check only **one** of the following seven boxes.

Individual/sole proprietor or single-member LLC

Limited liability company. Enter the tax classification (C=C corporation, S=S corporation, P=Partnership) ▶ _____

Other (see instructions) ▶ _____

C Corporation

S Corporation

Partnership

Trust/estate

4 Exemptions (codes apply only to certain entities, not individuals; see instructions on page 3):

Exempt payee code (if any) _____

Exemption from FATCA reporting code (if any) _____

(Applies to accounts maintained outside the U.S.)

5 Address (number, street, and apt. or suite no.) See instructions.

6 City, state, and ZIP code

7 List account number(s) here (optional)

Requester's name and address (optional)

Print or type.
See Specific Instructions on page 3.

Part I Taxpayer Identification Number (TIN)

Enter your TIN in the appropriate box. The TIN provided must match the name given on line 1 to avoid backup withholding. For individuals, this is generally your social security number (SSN). However, for a resident alien, sole proprietor, or disregarded entity, see the instructions for Part I, later. For other entities, it is your employer identification number (EIN). If you do not have a number, see *How to get a TIN*, later.

Note: If the account is in more than one name, see the instructions for line 1. Also see *What Name and Number To Give the Requester* for guidelines on whose number to enter.

Social security number

			-			-				
--	--	--	---	--	--	---	--	--	--	--

or

Employer identification number

			-							
--	--	--	---	--	--	--	--	--	--	--

Part II Certification

Under penalties of perjury, I certify that:

- The number shown on this form is my correct taxpayer identification number (or I am waiting for a number to be issued to me); and
- I am not subject to backup withholding because: (a) I am exempt from backup withholding, or (b) I have not been notified by the Internal Revenue Service (IRS) that I am subject to backup withholding as a result of a failure to report all interest or dividends, or (c) the IRS has notified me that I am no longer subject to backup withholding; and
- I am a U.S. citizen or other U.S. person (defined below); and
- The FATCA code(s) entered on this form (if any) indicating that I am exempt from FATCA reporting is correct.

Certification instructions. You must cross out item 2 above if you have been notified by the IRS that you are currently subject to backup withholding because you have failed to report all interest and dividends on your tax return. For real estate transactions, item 2 does not apply. For mortgage interest paid, acquisition or abandonment of secured property, cancellation of debt, contributions to an individual retirement arrangement (IRA), and generally, payments other than interest and dividends, you are not required to sign the certification, but you must provide your correct TIN. See the instructions for Part II, later.

Sign Here Signature of U.S. person ▶ _____ Date ▶ _____

General Instructions

Section references are to the Internal Revenue Code unless otherwise noted.

Future developments. For the latest information about developments related to Form W-9 and its instructions, such as legislation enacted after they were published, go to www.irs.gov/FormW9.

Purpose of Form

An individual or entity (Form W-9 requester) who is required to file an information return with the IRS must obtain your correct taxpayer identification number (TIN) which may be your social security number (SSN), individual taxpayer identification number (ITIN), adoption taxpayer identification number (ATIN), or employer identification number (EIN), to report on an information return the amount paid to you, or other amount reportable on an information return. Examples of information returns include, but are not limited to, the following.

- Form 1099-INT (interest earned or paid)

- Form 1099-DIV (dividends, including those from stocks or mutual funds)
- Form 1099-MISC (various types of income, prizes, awards, or gross proceeds)
- Form 1099-B (stock or mutual fund sales and certain other transactions by brokers)
- Form 1099-S (proceeds from real estate transactions)
- Form 1099-K (merchant card and third party network transactions)
- Form 1098 (home mortgage interest), 1098-E (student loan interest), 1098-T (tuition)
- Form 1099-C (canceled debt)
- Form 1099-A (acquisition or abandonment of secured property)

Use Form W-9 only if you are a U.S. person (including a resident alien), to provide your correct TIN.

If you do not return Form W-9 to the requester with a TIN, you might be subject to backup withholding. See What is backup withholding, later.

SPECIAL SPECIFICATIONS

DESCRIPTION OF WORK

This Project consists of the following work for the 2022 City Streets Overlay & Reconstruction Project in Pendleton, Oregon:

1. Construct curb, gutter, and ADA ramps.
2. Grind and overlay.
3. Two road reconstructions and one partial road reconstruction.
4. Adjust water valve boxes, and manholes.
5. Perform additional and incidental work as called for in the Specifications and Plans.

Completion deadline for all work: August 26, 2022.

PROJECT OVERVIEW

This Project shall include the removal and replacement with approximately 1,623.50 LF of City standard curb and gutter, and 453.50 SY of ADA ramps. There will also be 4,993.00 tons of asphalt placed for this project, 79 utility adjustments, and 5,725.00 LF of traffic striping.

The HMAC for this Project shall be ½" Dense Level 3 with PG 64-28 grade oil. HMAC shall be placed in 1 - 2" lift for overlays and 2 - 2" lifts for reconstructions. All edges unless stated otherwise on the drawings, shall be milled a minimum of 2" deep at the gutter line and tapered to zero depth 8' out from curb; all end joints shall be milled 2" deep from the intersection/tie-in point, tapered to zero depth 15' or 20' out from tie-in point as called out on the plans.

The Contractor shall be responsible for obtaining a railroad flagger and any permits required to pave up to the railroad crossing on SE Court Place.

Contractor to note that one lane of travel with the use of flaggers shall be provided at all times on SW 37th Street, SE Court Place, and SW Nye Avenue during working hours. At the end of the work day, two lanes of travel shall be provided with access into driveways and side streets, if applicable. Access to businesses along SW Nye Avenue and SE Court Place will need to be provided at all times. SW 28th Drive, SE Goodwin Avenue, NW Ellis Avenue, and NW 14th Street may be closed to thru traffic during working hours, but need to be reopened and accessible at the end of the work day.

1. ALL CONSTRUCTION

All construction shall be in compliance with the latest revision of the City of Pendleton Standard Specifications and the "Oregon Standard Specifications for Construction" (ODOT/APWA) latest revision, excluding Sections 00100 and 00745.95, unless otherwise noted in these special specifications.

2. STANDARDS APPLICABLE TO CONSTRUCTION

The following specifications shall be included by this reference as they may apply to this project. The most current versions of these specifications, which were in effect at the time of the first publication of the Invitation to Bid, are applicable.

- | | | |
|-----|--------|--------------------------------------------------------------------|
| A.1 | AASHTO | -American Association of State Highway & Transportation Officials. |
| A.2 | ACI | -American Concrete Institute |
| A.3 | AISI | -American Iron and Steel Institute |
| A.4 | ANSI | -American National Standards Institute |

- A.5 APWA -American Public Works Association
- A.6 ASME -American Society of Mechanical Engineers
- A.7 ASTM -American Society for Testing and Materials
- A.8 AWWA -American Water Works Association
- A.9 AWA -American Welding Society
- A.10 AWPA -American Wood Preservers Institute
- A.11 CSAA -Coating Standards Association
- A.12 CRSI -Concrete Reinforcing Steel Institute
- A.13 FHWA -Federal Highway Administration
- A.14 HI -Hydraulic Institute
- A.15 IEEE -Institute of Electrical & Electronic Engineers
- A.16 ICEA -Insulated Cable Engineers Association
- A.17 MUTCD -Manual on Uniform Traffic Control Devices (FHA)
- A.18 NBS -National Bureau of Standards
- A.19 NACE -National Association of Corrosion Engineers
- A.20 NEC -National Electric Code
- A.21 NEMA -National Electric Manufacturer's Association
- A.22 NLMA -National Lumber Manufacturer's Association
- A.23 OSHD -Oregon State Highway Department
- A.24 PCA -Portland Cement Association
- A.25 SPFA -Steel Plate Fabricators Association
- A.26 SSPC -Steel Structures Painting Council
- A.27 UL -Underwriters Laboratories, Inc.
- A.28 UBC -Uniform Building Code
- A.29 WWPA -Western Wood Products Association
- A.30 All applicable governmental building codes, and construction specifications in effect at the time of the first Advertisement for Bids. Where conflicts occur between the different specifications, these special specifications shall prevail over the above-cited specifications, followed by the City's Standard Specifications as a general rule, the most stringent specification for any conflicting specifications shall prevail. In any interpretation required of the specifications shall be referred to the City Engineer. Response shall be in writing and final.

3. SATURDAY, SUNDAY OR HOLIDAY WORK

The Contractor shall notify the City forty-eight (48) hours in advance of work that will be performed on Saturday, Sunday or Holidays or other than normal working hours. Normal working hours are 7:00 am to 6:00 pm, per City Ordinance No. 2287.

4. PERMITS AND LICENSES

The Contractor shall keep himself informed of all local ordinances, state, and federal laws in any manner affecting the work. The Contractor shall be responsible for obtaining a railroad flagger and any permits required to pave up to the railroad crossing on SE Court Place. All permits and licenses necessary for the prosecution of this work shall be secured and paid for by the Contractor.

5. EXCAVATION

All excavation material shall be unclassified material regardless to type, nature, characteristic, and/or condition of the material to be encountered. Excavation required is considered incidental to the items listed in the bid. The Contractor, by signing the proposal, has certified that they have carefully examined the Plans and working site. That they have satisfied themselves as to the nature and location of the work, quality and quantity of material required and the character of equipment and facilities needed to accomplish the work, and they have included any costs associated with the extra effort of excavating unclassified material, in the appropriate unit cost of item installed. There will be no separate pay item for rock excavation. Contractor is responsible for compaction of all backfill.

6. SCHEDULE

The Contractor shall submit a work schedule to the City for approval, five (5) days prior to commencing work. The Contractor shall submit weekly updates of the work schedule to the City's Project Manager.

7. NOTIFICATIONS

The Contractor shall make every effort possible to contact adjoining property owners of streets scheduled for road work. This effort shall be incidental to the contract. Contact efforts should include, but not be limited to signage (**lettering should be easily legible from a vehicle and be at least 3"-4" in size**), door knock and talks, letters, door hangars, and/or phone notifications, if possible. Contractor shall give written notification five (5) days prior and 24-hour advance notice to all residents and businesses along a street scheduled for road work. The notice shall describe the activity planned, when and if the street is to be closed and when it is scheduled to be reopened, and Contractor contact information. Contractor shall develop a work schedule to be approved by City. City will provide schedule to local media to help with public notification.

8. TRAFFIC CONTROL

If parked vehicles obstruct the progress of work after an appropriate notification of closure, requests for removal of the obstructive vehicles should be made through the City of Pendleton.

In addition to other requirements as set forth in the Special Conditions, other provisions shall include, but not be limited to:

- a. All traffic control shall meet the provisions of the Manual on Uniform Traffic Control Devices. It is the Contractor's responsibility to implement and maintain all traffic control.
- b. Contractor shall submit a traffic control plan for approval. Overall schedule and traffic control plan must be submitted to and approved by City five (5) days prior to commencing work.
- c. The Contractor shall at all times maintain such, flagmen, signs, lights, barricades and other safety devices, all necessary to insure the safety and convenience of the public and its employees, and to protect the work.
- d. The Contractor will insure that during non-working hours, that on-call staff is available to maintain all traffic control devices for the project. The Contractor shall provide the City of Pendleton with up-to-date information of these persons. Failure to comply with the provision will cause the Contractor to be billed for any services required to be provided by the City of Pendleton, to provide adequate protection to the traveling public during non-working hours.
- e. Traffic control and temporary protection and correctional devices shall be used outside the limits of the project when they have direct bearing or reference on the work under contract.
- f. The Contractor shall at all times keep the road under construction and routes used for hauling the material, that are open to traffic, free from mud, rock, oil and other debris that may create traffic hazards, and shall provide adequate personnel to alleviate any danger. Roads shall be inspected and cleaned of any such debris at the close of every working day, or as often as deemed necessary by the City. On streets that are not closed at the end of the day, the Contractor shall leave the road in such condition that the streets that are open to traffic can be traveled without damage to work, personal property, or without danger to the public.
- g. Streets may be closed as approved by City of Pendleton on a case by case basis. Contractor shall be responsible for all necessary signing (lettering should be easily legible from a vehicle and be at least 3"-4" in size) and public notification for closures and detours.
- h. The Contractor will be concerned with the following factors in restricting traffic flow. The approved traffic control and channelization plan, emergency vehicle access, permissible hours of restriction, sufficient traffic control personnel and devices, prior warning to public residents and a minimum forty-eight (48) hours advance notification to the City.

The City may direct the Contractor to provide additional traffic control devices to assure the safety of pedestrian and vehicular traffic, as the City deems necessary. It shall be the responsibility of the Contractor to move, replace, position, or remove any sign as required due to the change of work schedule due to weather or other unforeseen circumstances.

9. SURVEY LAYOUT

The City shall provide all survey layout and functions required to complete the job. Contractor shall be responsible for protecting survey stakes once they have been placed. Contractor will be required to give the City forty-eight (48) hours advance notice for any survey needs. The Contractor is responsible for ADA ramp layout with the City's review and supervision.

10. CURB AND GUTTER

Curb and gutter shall meet City of Pendleton standards. Price per foot shall include but not be limited to: saw cut of existing curb, removal and disposal of existing, excavation and grading, 2" minimum compacted base rock under curb and gutter, all forms, pouring and finishing work. Incidental items such as removing and replacing a minimum of 2' of the existing driveway approaches or existing walkways, and removing and replacing landscaping in order to install the new curb and gutter shall be considered in the unit price for this bid item. The driveway approaches, walkways, and landscaping shall be replaced to "AS GOOD or BETTER" condition. The Contractor shall match the type of landscaping adjacent to the structure or that was pre-existing. If an irrigation system is impacted in any way, Contractor will cap affected area and notify property owner immediately (within the hour). If related to form work, once forms are removed, Contractor will re-establish fully functioning irrigation system to "AS GOOD or BETTER" within 24-hours of forms being pulled and notify property owner of repair by the close of the work day.

11. SIDEWALK

Sidewalk shall meet City of Pendleton standards. Price per square yard shall include but not be limited to: saw cut of existing, removal and disposal of existing, excavation and grading, installation of compacted base rock under sidewalk and driveway approaches, all forms, pouring and finishing work. Any excess spoils shall be hauled to an offsite location at no additional cost.

There shall be 2" to 4" of 3/4" minus crushed base rock and the base rock shall be compacted to not less than 95% relative compaction. Sidewalks shall be constructed using 5 sack concrete mix having a minimum compressive strength of 3000 psi, 28 days after placement and a slump range of 3" to 5". Sidewalks shall have a minimum concrete thickness of 4".

12. DRIVEWAY APPROACH

Driveway approaches shall meet City of Pendleton standards. Price per square yard shall include but not be limited to: saw cut of existing, removal and disposal of existing, excavation and grading, installation of compacted base rock under sidewalk and driveway approaches, all forms, pouring and finishing work. Any excess spoils shall be hauled to an offsite location at no additional cost.

There shall be 2" to 4" of 3/4" minus crushed base rock and the base rock shall be compacted to not less than 95% relative compaction. Driveway approaches shall be constructed using 5 sack concrete mix having a minimum compressive strength of 3000 psi, 28 days after placement and a slump range of 3" to 5". Driveway approaches shall have a minimum concrete thickness of 5".

13. WALKWAY

This bid item is for the removal and replacement of a walkway as called out on the plans. Price per square yard shall include but not be limited to saw cut, removal and disposal of existing, excavation and grading, installation of compacted base rock, all forms, pouring and finishing work. Any excess spoils shall be hauled to an offsite location at no additional cost. There shall be 2" to 4" of 3/4" minus crushed base rock and the base rock shall be compacted to not less than 95% relative compaction. Walkways shall be constructed using 5 sack concrete mix having a minimum compressive strength of 3000 psi, 28 days after placement and a slump range of 3" to 5". Walkways shall have a minimum concrete thickness of 4".

14. ADA RAMP

ADA ramps shall meet City, State, and/or Federal ADA standards, as called out on the plans. Price per square yard shall include but not be limited to: saw cut, removal and disposal of existing ramp and sidewalk, excavation, compacted base rock under the ramp, all forms, pouring and finishing work as well as truncated domes that meet State and Federal ADA standards. The removal and replacement of any landscaping removed in order to install the new ADA ramp shall be considered incidental to this bid item. The Contractor shall match the type of landscaping that is adjacent to the structure or that was pre-existing. Any excess spoils shall be hauled to an offsite location at no additional cost. This bid item is replacing existing ramps or installing ramps where none currently exist so each one is unique and some may require ramp curbs which shall be included in the price per square yard and should not be confused with the Curb and Gutter bid item or Sidewalk bid item. If an irrigation system is impacted in any way, Contractor will cap affected area and notify property owner immediately (within the hour). If related to form work, once forms are removed, Contractor will re-establish fully functioning irrigation system to "AS GOOD or BETTER" within 24-hours of forms being pulled and notify property owner of repair by the close of the work day.

15. ASPHALT DRIVEWAY

Residential asphalt driveways shall consist of a minimum nominal asphalt thickness of three inches (3") over four inches (4") nominal depth of 3/4" minus base rock, compacted to 95% optimum density. Commercial asphalt driveways shall consist of a minimum nominal asphalt thickness of four inches (4") over four inches (4") nominal depth of 3/4" minus base rock, compacted to 95% optimum density. Payment of this item shall include all labor, tools, equipment, and materials necessary for a complete and approved job.

16. RESTORATIVE LANDSCAPING

The Contractor shall repair the landscaping behind or adjacent to the sidewalk, curbs, ADA ramps, driveways, and walkways to "AS GOOD or BETTER" condition. This bid item is to include all labor, tools, equipment, and materials necessary for a complete and approved job. Landscaping materials will differ with each project site and may include but not be limited to top soil and sod or grass seed, 3/4" minus gravel, or river cobbles. Contractor shall install a weed barrier prior to placing 3/4" minus gravel or river cobbles. The Contractor shall match the type of landscaping that is adjacent to the structure or that was pre-existing.

17. STREET RECONSTRUCTION

- a. **Saw cutting:** Shall be measured by the total lineal feet of single saw cut of asphalt. In the case where curb and gutter is being removed and replaced, the bid item saw cutting includes the cutting of the asphalt, existing walkways, sidewalks, and driveway approaches. Enclosed cutting amounts are approximate.
- b. **Excavation:** Excavation shall be fourteen inches (14") in depth except for SW Nye Avenue which shall be sixteen inches (16") and shall include but not be limited to all work necessary to clear, remove, and dispose of all asphalt, excess base rock, and other rock or debris unsuitable sub-base, as necessary to complete the construction.
- c. **Geotextile Fabric:** Shall include but not be limited to all work necessary to install fabric according to manufacturer specs. Fabric used shall be Mirafi 600X, or approved equivalent.
- d. **2"-0" Base Rock:** 2"-0" shall be placed at a minimum six inches (6") nominal depth except for SW Nye Avenue which shall be a minimum eight inches (8") nominal depth, and shall be clean well graded pit run rock meeting material specifications of 2018 Oregon Department of Transportation (ODOT) Standard Specifications for Construction, Section 02630, compacted to 95% optimum density. Nominal maximum requirement size two inches (2").
- e. **3/4"-0" Base Rock:** 3/4" minus base rock shall be placed at a minimum four inches (4") nominal depth, and compacted to 95% optimum density. Payment for this item shall be "in place" for all labor, tools, equipment, 3/4" minus base rock and other materials necessary for a complete and approved job.

- f. **Asphalt:** Asphalt shall be Level 3 HMAC ½” Dense with PG 64-28 oil, placed in 2 - 2” compacted lift. Asphalt shall meet the latest version of ODOT Standard Specifications for Construction, Section 00745 requirements. Payment of this item shall include all labor, tools, equipment, and materials necessary for a complete and approved job.
- g. **Striping and Pavement Marking:** The Contractor shall be responsible for all the road striping on SW 37th Street, SE Court Place, SW Nye Avenue, and SE Goodwin Avenue. Measurement and payment shall be by the linear foot for striping. The contractor shall be responsible for maintaining the location of all pavement striping and markers during the project and re-painting same after the overlay or reconstruction has been completed. Two coats of paint shall be applied. ODOT 00850 – Common Provisions for Pavement Markings, 00860 – Longitudinal Pavement Markings - Paint, 00865 – Longitudinal Pavement Markings – Durable.
- h. **Work progression:** Once work commences on a street, the Contractor shall have thirty (30) working days to have the ADA ramps, curb and gutters completed, replace driveway approaches and walkways, and repave the street. Landscaping behind the curbs, sidewalks, and ADA ramps, and utility adjustments to final grade must be completed before the Contract Completion Date.
- i. **Utility Adjustment:** Contractor will supply materials to adjust sanitary manholes, storm manholes, water valves and sewer clean out boxes as necessary. All manhole adjustments shall be raised per City of Pendleton Standard Drawing 307C. Water valves shall be raised according to City of Pendleton Standard Drawing 402. Sewer cleanouts shall be raised according to City of Pendleton Standard Drawing 309A. Contractor is responsible for the actual adjustment of the utility. Any lost or broken materials will be furnished by the City of Pendleton.
- j. **General:** Contractor shall be responsible for any damage to curbs or sidewalks. Contractor will be liable for replacing damaged curbs or sidewalks at no cost to the City.
- k. **Clean-up:** Contractor shall be responsible for the timely clean-up of tack, asphalt, concrete, forms, and other construction debris that gets tracked or spilled onto the curbs, gutters, sidewalks, driveways, yards, and surrounding roadways prior to leaving the job site each day.

18. STREET OVERLAY

- a. **Emulsified Asphalt Tack Coat:** Comply with Section 00730 of the latest version of ODOT Standard Specifications for Construction approved in advance by the City of Pendleton, except that the price for this item shall be included in the price per ton of HMAC.
- b. **HMAC:** Pavement shall be Level 3 HMAC ½” Dense with PG 64-28 oil, and shall comply with Section 00745 of the latest version of ODOT Standard Specifications for Construction approved in advance by City of Pendleton. Workmanship and quality shall meet the requirements of the Oregon Standard Specifications and testing as specified by same.
- c. **Cold Plane Pavement Removal:** Comply with Section 00620 of the latest version of ODOT Standard Specifications for Construction approved in advance by the City of Pendleton. Payment for this item shall be by the “square yard” with an average depth of 1” (0” to 2”) at 8’ wide along the concrete gutter. End joints at the beginning and end of the project shall be 15’-20’ tapers (0” to 2”) as called out on the plans.
- d. **Pre-leveling:** Comply with Sections 00744 & 00745 of the latest version of Oregon Standard Specifications for Construction approved in advance by the City of Pendleton.
- e. **Striping and Pavement Marking:** The Contractor shall be responsible for all the road striping on SW 37th Street, SE Court Place, SW Nye Avenue, and SE Goodwin Avenue. Measurement and payment shall be by the linear foot for striping. The contractor shall be responsible for maintaining the location of all pavement striping and markers during the project and re-painting same after the overlay or reconstruction has been completed. Two coats of paint shall be applied. ODOT 00850 – Common Provisions for Pavement Markings, 00860 – Longitudinal Pavement Markings - Paint, 00865 – Longitudinal Pavement Markings – Durable.

- f. **Work progression:** Once work commences on a street, the Contractor shall have twenty (20) calendar days for each schedule of street overlays. On overlay streets also requiring ADA ramp construction, curb and gutter replacement, driveway approach and walkway replacement, an additional ten (10) calendar days will be added to the completion progression schedule. Landscaping behind the curbs, sidewalks, and ADA ramps, and utility adjustments to final grade must be completed before the Contract Completion Date.
- g. **Utility Adjustment:** Contractor will supply materials to adjust sanitary manholes, storm manholes, water valves and sewer clean out boxes as necessary. All manhole adjustments shall be raised per City of Pendleton Standard Drawing 307C. Water valves shall be raised according to City of Pendleton Standard Drawing 402. Sewer cleanouts shall be raised according to City of Pendleton Standard Drawing 309A. Contractor is responsible for the actual adjustment of the utility. Any lost or broken materials will be furnished by the City of Pendleton.
- h. **General:** Contractor shall be responsible for street cleanliness prior to overlay. Vegetation and any substances or debris that may interfere with the overlay shall be removed or treated. City will periodically sample the asphalt and have it tested for conformity with specifications. Contractor shall be responsible for any damage to curbs and will be responsible for replacing damaged curbs at no cost to the City.
- i. **Clean-up:** Contractor shall be responsible for the timely clean-up of tack, asphalt, concrete, forms, and other construction debris that gets tracked or spilled onto the curbs, gutters, sidewalks, driveways, yards, and surrounding roadways prior to leaving the job site each day.

19. INCIDENTAL ITEMS

All materials and work shown on the plans or necessary to complete the job and receive approval of the project, which are not identified as a separate pay item on the proposal, shall not be measured for payment separately but shall be considered as subsidiary obligations of the Contractor.

20. CONTRACT COMPLETION TIME AND LIQUIDATED DAMAGES

Contractor shall furnish in writing a work schedule for the Project, with updated schedules at least every two weeks. **This Project must be completed no later than August 26, 2022.** Each street shall be considered its own schedule for project work progression milestones and deadlines. Liquidated damages will be assessed at one percent (1%) per day of total cost of work not yet completed for each of the contract schedules (or streets), or \$500 per calendar day for each schedule, whichever is greater for all work not yet completed by the contract deadline or work progression timeline, whichever occurs first. The Contract deadline is August 26th, 2022. The work progression timeline, once the work commences for each street, is thirty (30) calendar days for each street reconstruction schedule, and twenty (20) calendar days for each schedule of street overlays. On overlay streets also requiring ADA ramp construction, curb and gutter replacement, driveway approach and walkway replacement, an additional ten (10) calendar days will be added to the completion progression schedule. Landscaping behind the curbs, sidewalks, and ADA ramps, and utility adjustments to final grade must be completed before the Contract Completion Date, however lane closures on any given schedule (or street) to perform this work can only be a maximum of 8-hours or that day will be counted as a day of project progression default if past the progression schedule timeline.

21. RECOVERY OF COSTS

As work on the Contract progresses, the City shall, upon request, inform the Contractor of all accrued costs. If punch list items are not completed after the 12-month period following substantial completion, the City will retain the remaining retainage and consider the contract closed. The City will complete the punch list items and any cost above the remaining retainage withheld will be sought by placing a lien against the Contractor's bond.

22. WORKING HOURS, RESTRICTIONS

Normal working hours are Monday through Friday - 7:00 am to 5:00 pm. Work may extend beyond this time period with prior written permission from the City. The Contractor shall notify the City forty-eight (48) hours in advance if work will be performed on Saturday, Sunday or Holidays or other than normal working hours.

Per Ordinance No. 2287, no work that produces dust or flying debris shall be performed or equipment utilized that produces noise of sufficient volume to disturb the sleep or repose of occupants of neighboring property between the hours of 6:00 pm and 7:00 am without expressed written permission from the City.

APPROVED CONSTRUCTION MATERIALS
SANITARY, STORM SEWER

SANITARY SEWER MAIN: PVC PIPE AND FITTINGS CONFORMING TO THE REQUIREMENTS OF ASTM D3034 SDR 35, ASTM F679 OR ASTM F794. JOINTS CONFORMING TO ASTM D3212 AND ELASTOMERIC GASKETS CONFORMING TO ASTM F477. ADS SANITITE HP PIPE OR HANCORE SANITITE, OR APPROVED EQUIVALENT. PIPE AND FITTINGS SHALL CONFORM TO ASTM F2764. JOINTS SHALL BE SILT TIGHT AND NON-RATED WATERTIGHT MEETING ASTM D3212 AND ELASTOMERIC GASKETS SHALL CONFORM TO ASTM F477.

SEWER SERVICES: SAME AS SANITARY SEWER MAIN OR ALTERNATE MATERIAL: ABS PIPE WITH GLUED JOINTS AND FLEXIBLE WATER TIGHT GASKET TO CONNECT TO SEWER MAIN SERVICE WYE.

STORM SEWER MAINS: ADS N-12 OR HANCORE SURE-LOK HDPE PIPE, OR APPROVED EQUIVALENT. PIPE AND FITTINGS SHALL CONFORM TO ASTM F2648, AASHTO M252, M294, OR MP7-97. JOINTS SHALL BE SILT TIGHT AND NON-RATED WATERTIGHT MEETING ASTM F477. OR PVC PIPE AND FITTINGS CONFORMING TO THE REQUIREMENTS OF ASTM D3034 SDR 35, ASTM F679, OR ASTM F794. JOINTS CONFORMING TO ASTM D3212 AND ELASTOMERIC GASKETS CONFORMING TO ASTM F477.

LOCATE WIRE: ALL PIPE MATERIALS WILL HAVE SOLID GREEN #12 AWG LOCATE WIRE FOR SEWER AND STORM. SPLICE KITS SHALL BE 3M-DIRECT BURY SPLICE KIT DBR/Y-6. WIRE TO BE CONTINUOUS AND ATTACHED BY 6" OF 2" DUCT TAPE TO MAIN AND ALL RISERS AT MAXIMUM 10' INTERVALS, WITH ENOUGH WIRE BROUGHT TO SURFACE AT EVERY LOCATION TO EXTEND MINIMUM 6" ABOVE FINISHED GRADE UNLESS OTHERWISE NOTED. TO BE TESTED AFTER BEING BURIED BUT BEFORE FINAL APPROVAL.

ASPHALT CONCRETE: PER CITY TYPICAL ROADWAY STANDARDS, OR DESIGNED BY AN OREGON LICENSED PROFESSIONAL ENGINEER USING THE LATEST VERSION OF THE ODOT CONTRACTOR MIX DESIGN GUIDELINES FOR ASPHALT CONCRETE. STRUCTURAL SECTION WILL BE DESIGNED USING THE LATEST VERSION OF THE ASPHALT PAVEMENT DESIGN GUIDE PUBLISHED BY APAO.



TESTING REQUIREMENTS

SANITARY SEWER: AIR PRESSURE TIME DROP METHOD PER OREGON STD SPECS 00445.72. MAX PRESSURE = 3.5 PSIG, FOR 15 MINUTES. ON NEW CONSTRUCTION, VISUAL TV INSPECTION.

STORM SEWER: VISUAL CCTV INSPECTION.

ASPHALT CONCRETE: AS DIRECTED BY THE CITY: REFERENCE TO THE OREGON STD SPECS ARE REFERRING TO THIS LATEST VERSION OF THE ODOT/APWA OREGON STD SPECS FOR CONSTRUCTION.

1. EMERSION-COMPRESSION (RETAINED STRENGTH).
2. GRADATION AND OIL CONTENT.
3. VOIDS AND COMPACTION.
4. RESILIENT MODULUS.

 <p>ENGINEERING DEPARTMENT 500 S.W. DORION AVENUE PENDLETON, OREGON 97801 VOICE: (541) 966-0203 FAX: (541) 966-0251</p>	<p>APPROVED BY</p> 	<p>APPROVED CONSTRUCTION MATERIALS</p>	<p>NO SCALE</p>
	<p>FEBRUARY 2019 APPROVAL DATE</p> <p>_____ REVISED DATE</p>		<p>DWG NO. 101A</p>

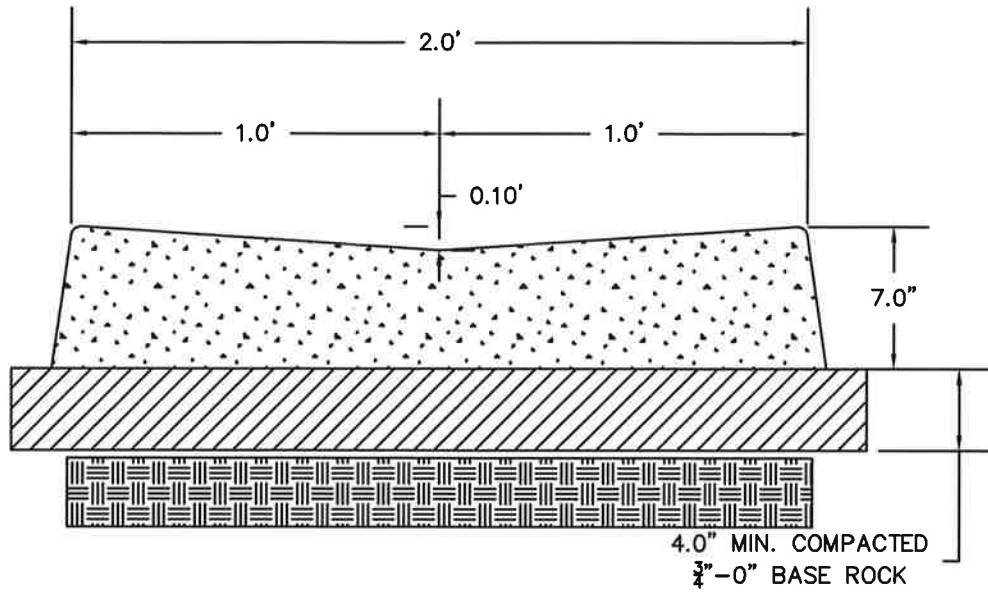

CROSS-SECTION

NOTES:

1) CONCRETE TO BE 3000 P.S.I AT 28 DAYS, 6 SACK MIX.

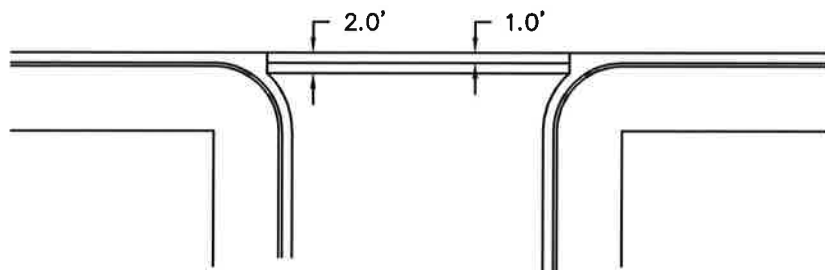
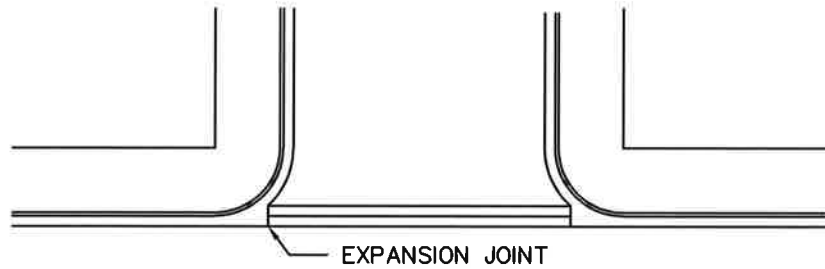

PLAN VIEW



ENGINEERING
DEPARTMENT
500 S.W. DORION
AVENUE PENDLETON,
OREGON 97801
VOICE: (541) 966-0203
FAX: (541) 966-0251

APPROVED BY

[Signature]

APPROVAL DATE

REVISED DATE

STANDARD
CROSS-GUTTER

NO SCALE

DWG NO.

204

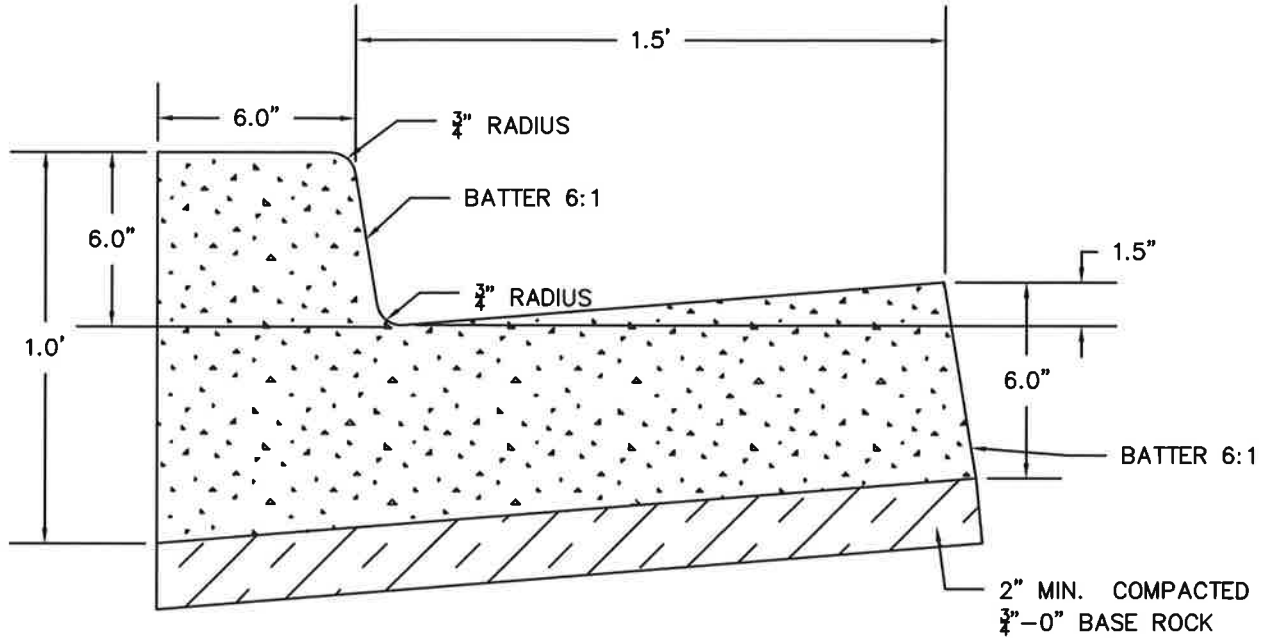

NOTES:

- 1) CONCRETE SHALL HAVE A MINIMUM COMPRESSIVE STRENGTH OF 3000 PSI, 28 DAYS AFTER PLACEMENT, USING 5 SACK MIX.
- 2) EXPANSION JOINTS SHALL BE LOCATED AT THE BEGINNING AND END OF EACH STRAIGHT RUN, AT 30 FOOT INTERVALS, AND AT SUCH PLACES AS NECESSITY MAY REQUIRE AS DIRECTED BY THE ENGINEER.
- 3) CONTRACTION JOINTS SHALL BE LOCATED AT INTERVALS NOT TO EXCEED 15 FEET AND MAY BE OMITTED WHERE EXPANSION JOINTS ARE AT LESS THAN 25 FOOT INTERVALS.
- 4) BASE ROCK SHALL BE 3/4" MINUS CRUSHED ROCK AND SHALL BE COMPACTED TO NOT LESS THAN 95% RELATIVE COMPACTION.



ENGINEERING
DEPARTMENT
500 S.W. DORION
AVENUE PENDLETON,
OREGON 97801
VOICE: (541) 986-0203
FAX: (541) 986-0251

APPROVED BY

[Signature]

APPROVAL DATE

REVISED DATE

**STANDARD CURB
& GUTTER**

NO SCALE

DWG NO.

205

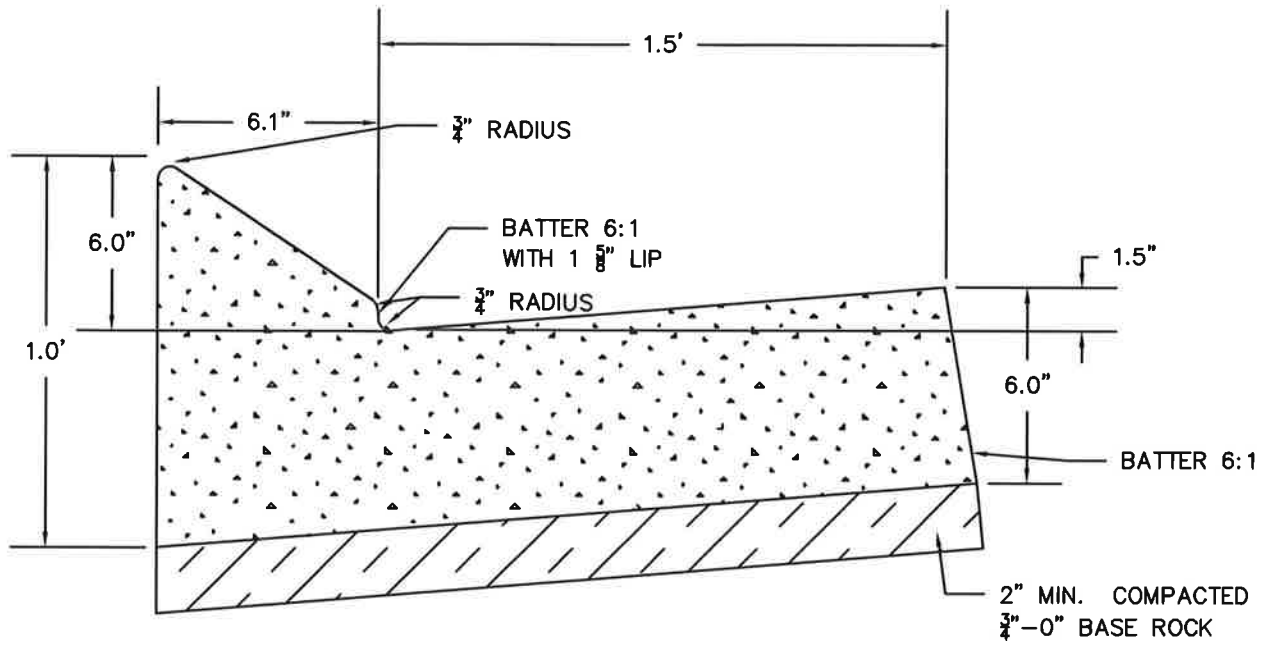

NOTES:

- 1) CONCRETE SHALL HAVE A MINIMUM COMPRESSIVE STRENGTH OF 3000 PSI, 28 DAYS AFTER PLACEMENT, USING 5 SACK MIX.
- 2) EXPANSION JOINTS SHALL BE LOCATED AT THE BEGINNING AND END OF EACH STRAIGHT RUN, AT 30 FOOT INTERVALS, AND AT SUCH PLACES AS NECESSITY MAY REQUIRE AS DIRECTED BY THE ENGINEER.
- 3) CONTRACTION JOINTS SHALL BE LOCATED AT INTERVALS NOT TO EXCEED 15 FEET AND MAY BE OMITTED WHERE EXPANSION JOINTS ARE AT LESS THAN 25 FOOT INTERVALS.
- 4) BASE ROCK SHALL BE $\frac{3}{4}$ " MINUS CRUSHED ROCK AND SHALL BE COMPACTED TO NOT LESS THAN 95% RELATIVE COMPACTION.



ENGINEERING
DEPARTMENT
500 S.W. DORION
AVENUE PENDLETON,
OREGON 97801
VOICE: (541) 966-0203
FAX: (541) 966-0251

APPROVED BY

APPROVAL DATE

REVISED DATE

**MOUNTABLE CURB
& GUTTER**

NO SCALE

DWG NO.

205A

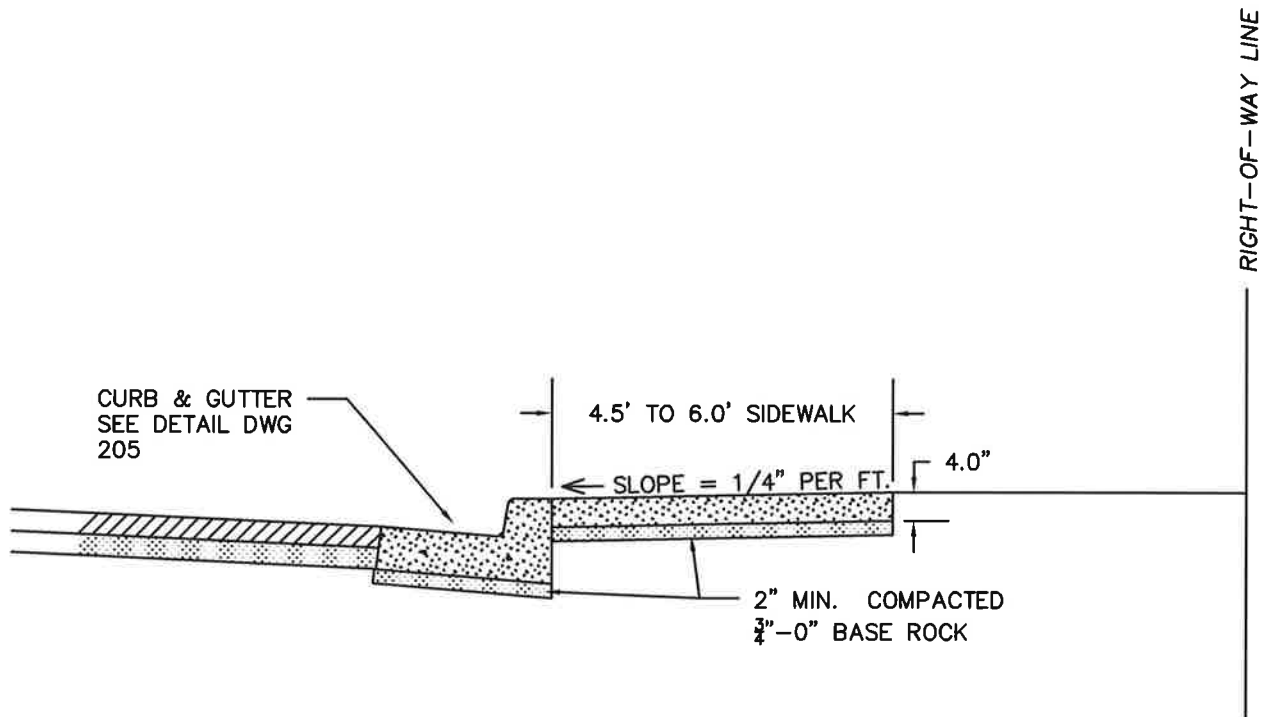

NOTES:

- 1) CONCRETE SHALL HAVE A MINIMUM COMPRESSIVE STRENGTH OF 3000 PSI, 28 DAYS AFTER PLACEMENT, USING 5 SACK MIX, WITH A SLUMP RANGE OF 3" TO 5".
- 2) BASE ROCK SHALL BE 3/4" MINUS CRUSHED ROCK AND SHALL BE COMPACTED TO NOT LESS THAN 95% RELATIVE COMPACTION.
- 3) MINIMUM SIDEWALK THICKNESS SHALL BE 4", EXCEPT AT DRIVEWAYS.
- 4) RESIDENTIAL DRIVEWAY THICKNESS SHALL BE 5". INDUSTRIAL DRIVEWAY THICKNESS SHALL BE 6" OR 5" WITH 6"X 6" WELDED WIRE MESH. SEE DRIVEWAY APPROACH STANDARD DRAWING 211.



ENGINEERING
DEPARTMENT
500 S.W. DORION
AVENUE PENDLETON,
OREGON 97801
VOICE: (541) 966-0203
FAX: (541) 966-0251

APPROVED BY

[Signature]

APPROVAL DATE

REVISED DATE

**RESIDENTIAL SIDEWALK
STANDARDS**

NO SCALE

DWG NO.

208

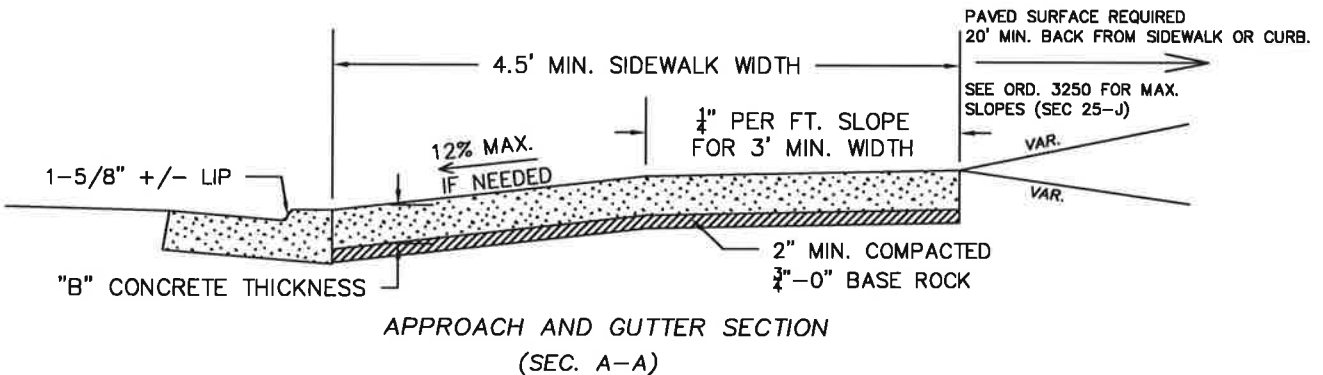
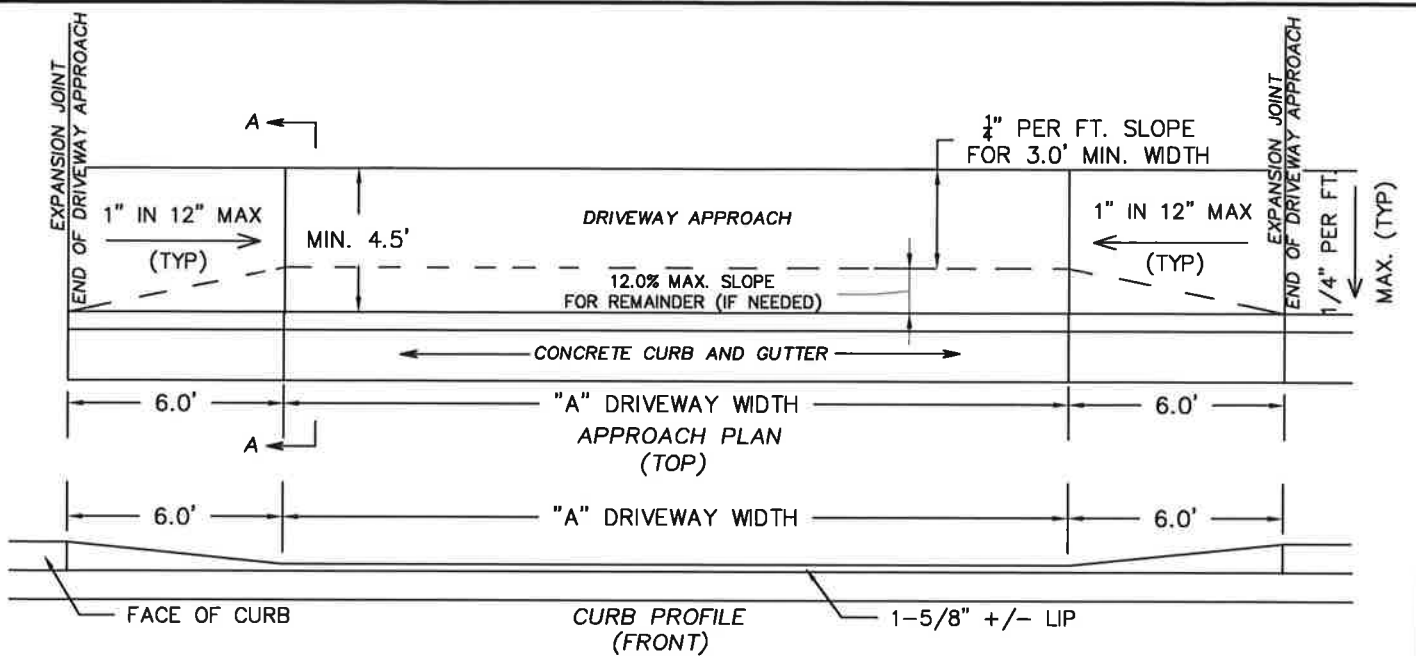



DIMENSIONS		
TYPE OF DRIVEWAY	"A" WIDTH	"B" CONCRETE THICKNESS
RESIDENTIAL		
SINGLE	14 FEET	5 INCHES
DOUBLE	22 FEET	5 INCHES
DOUBLE WITH PLANNING VARIANCE	33 FEET	5 INCHES
COMMERCIAL		
MAXIMUM SPEED 25 M.P.H	30 FEET	6 INCHES *
OVER 25 M.P.H	35 FEET	6 INCHES *

* OR 5 INCHES DEPTH WITH 6" X 6" WELDED WIRE MESH

NOTES:

- 1) COMMERCIAL AND INDUSTRIAL SIDEWALKS ADJACENT TO THE ENDS OF THE DRIVEWAY APPROACH SHALL MAINTAIN DRIVEWAY APPROACH THICKNESS "B" FOR AT LEAST 3 FT.
- 2) TOOLED JOINTS REQUIRED AT ALL GRADE BREAKS, AND AT A MAXIMUM 6' SPACING.

 <p>ENGINEERING DEPARTMENT 500 S.W. DORION AVENUE PENDLETON, OREGON 97801 VOICE: (541) 966-0203 FAX: (541) 966-0251</p>	<p>APPROVED BY</p> 	<h2>DRIVEWAY APPROACH STANDARD</h2>	NO SCALE
	<p>APPROVAL DATE</p> <p>REVISED DATE</p>		<p>DWG NO.</p> <h1>211</h1>

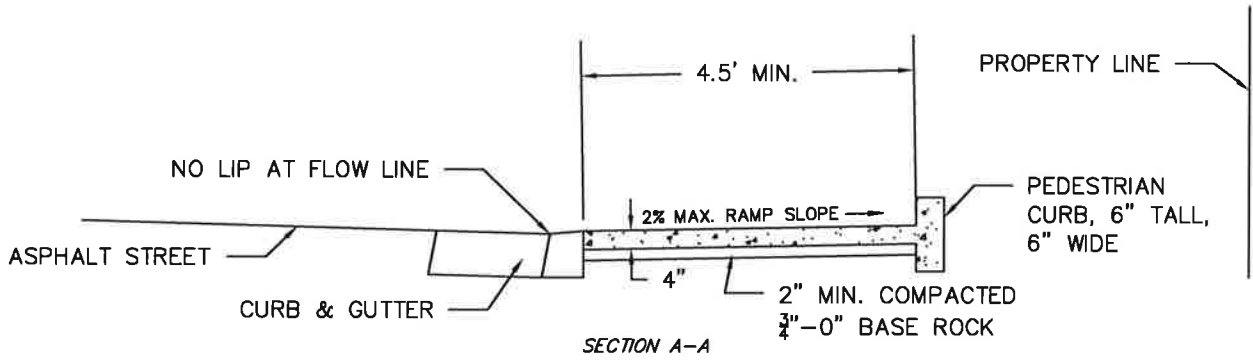
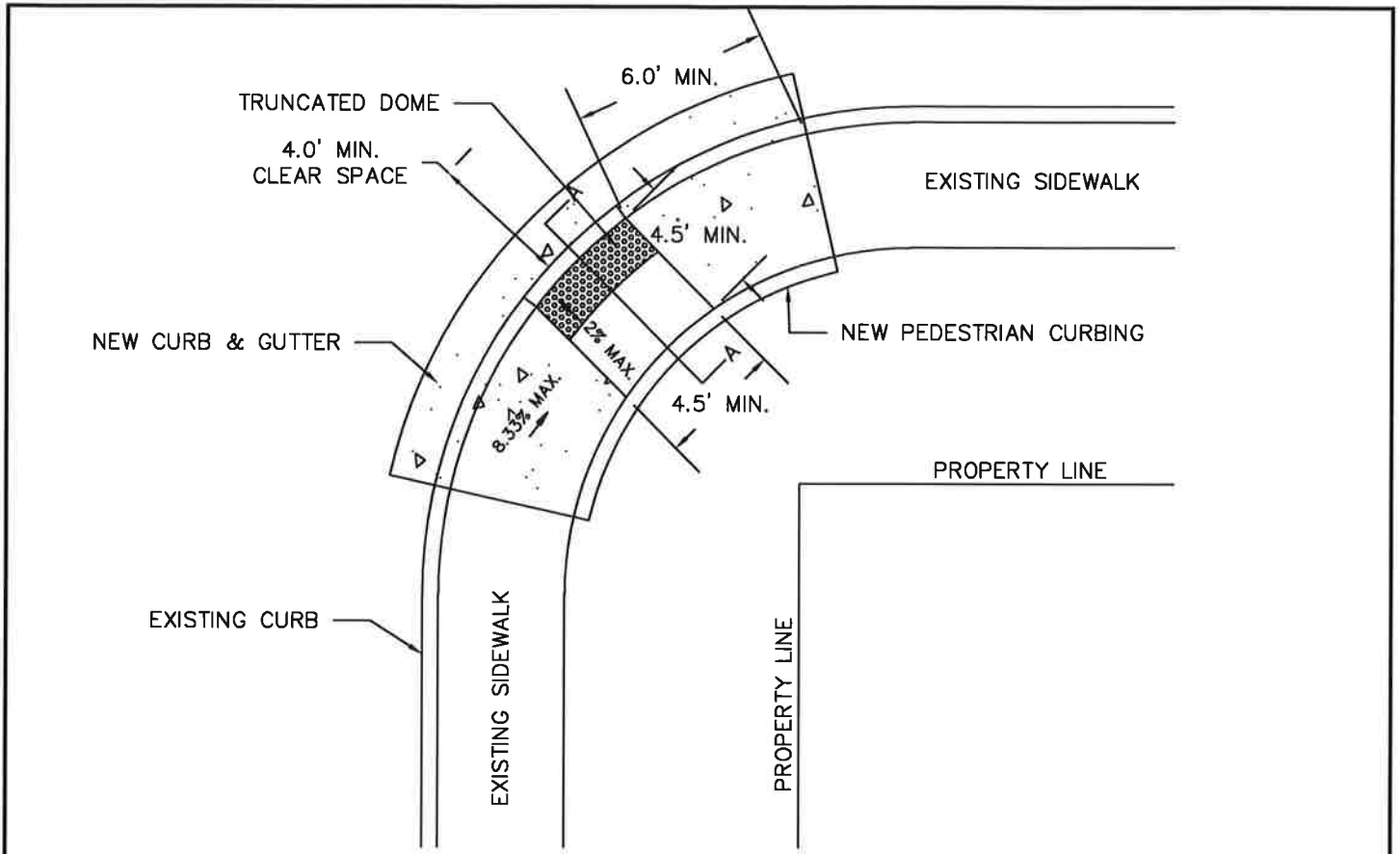

NOTES:

- 1) CONCRETE SHALL HAVE A MINIMUM COMPRESSIVE STRENGTH OF 3000 PSI, 28 DAYS AFTER PLACEMENT, USING 5 SACK MIX, WITH A SLUMP RANGE OF 3" TO 5".
- 2) BASE ROCK SHALL BE 3/4" MINUS CRUSHED ROCK AND SHALL BE COMPACTED TO NOT LESS THAN 95% RELATIVE COMPACTION.
- 3) PLACE TRUNCATED DOMES IN THROAT OF RAMP ONLY FOR THE FIRST 2 FEET.
- 4) TOOLED JOINTS ARE REQUIRED AT ALL SIDEWALK RAMP SLOPE BREAK LINES.



ENGINEERING DEPARTMENT
 500 S.W. DORION AVENUE
 PENDLETON, OREGON 97801
 VOICE: (541) 966-0203
 FAX: (541) 966-0251

APPROVED BY

 APPROVAL DATE

 REVISED DATE

ADA RAMP STANDARDS

NO SCALE
 DWG NO.
213

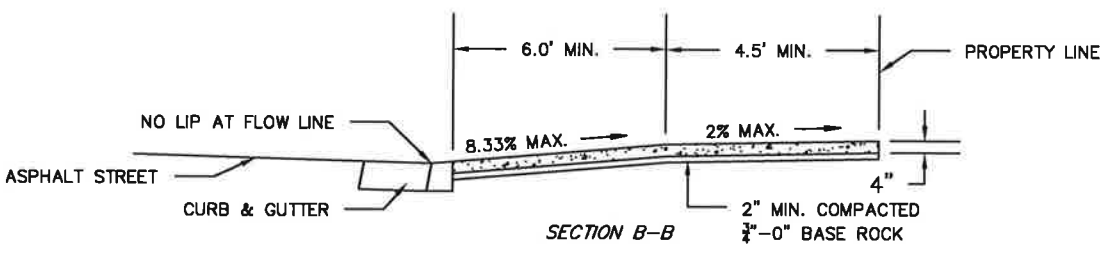
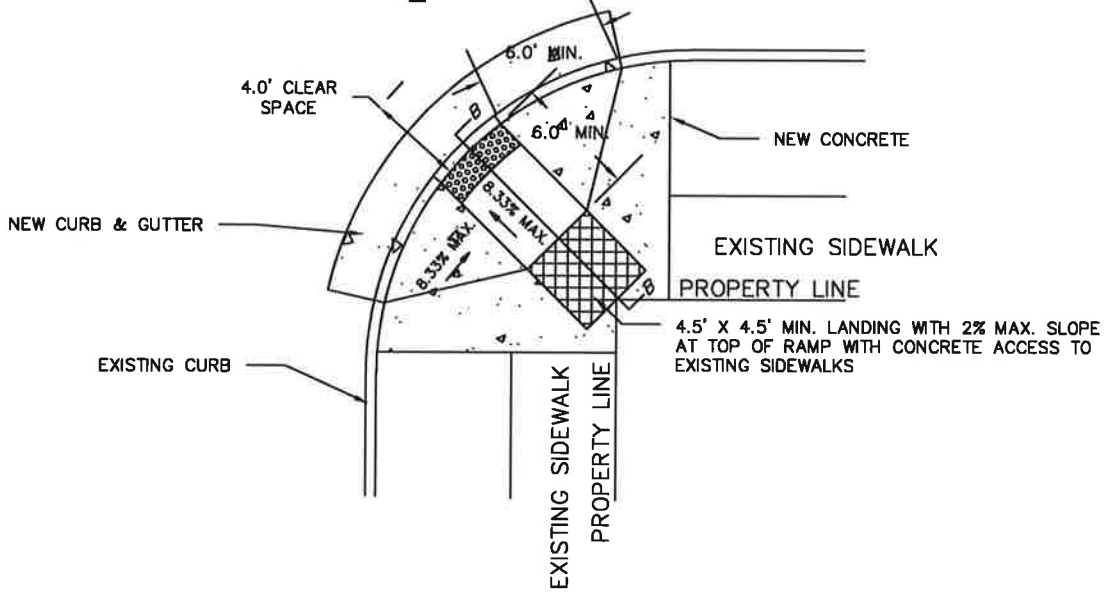
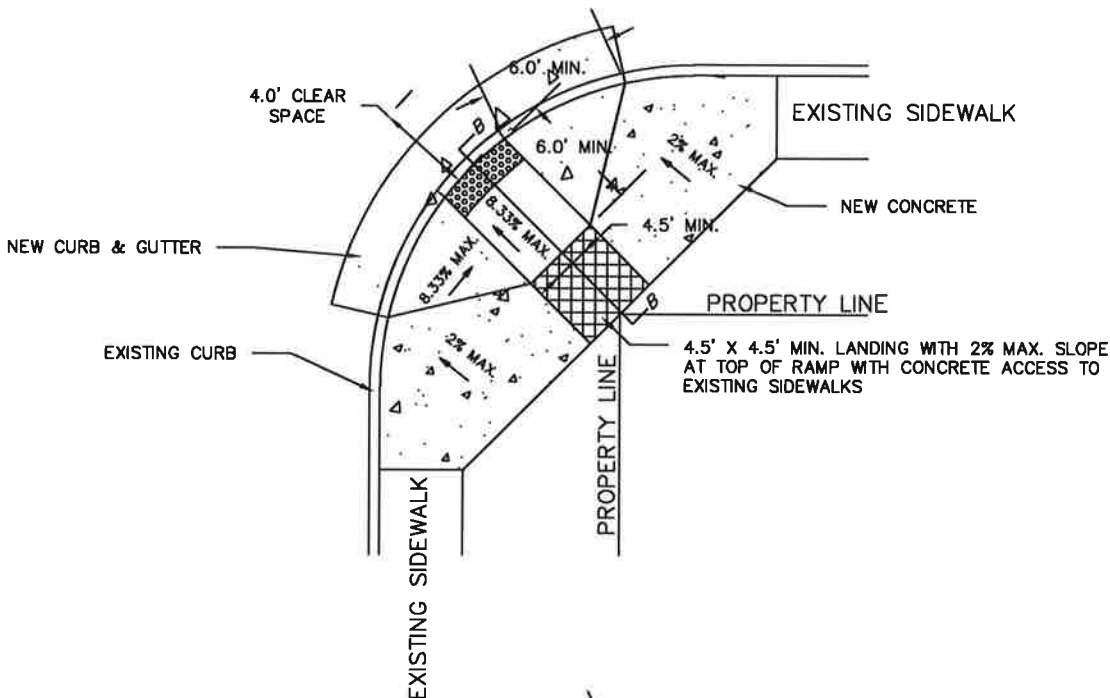

ENGINEERING
DEPARTMENT
500 S.W. DORION
AVENUE PENDLETON,
OREGON 97801
VOICE: (541) 966-0203
FAX: (541) 966-0251

APPROVED BY
[Signature]
APPROVAL DATE
REVISED DATE

ADA RAMP
STANDARDS

NO SCALE
DWG NO.
213A

SEE NOTE 2

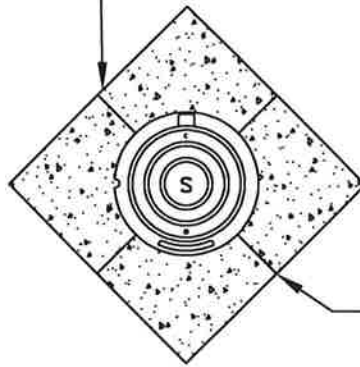

DIRECTION OF TRAFFIC

HAND TROWELED CONTROL JOINT (TYP)

TOP VIEW

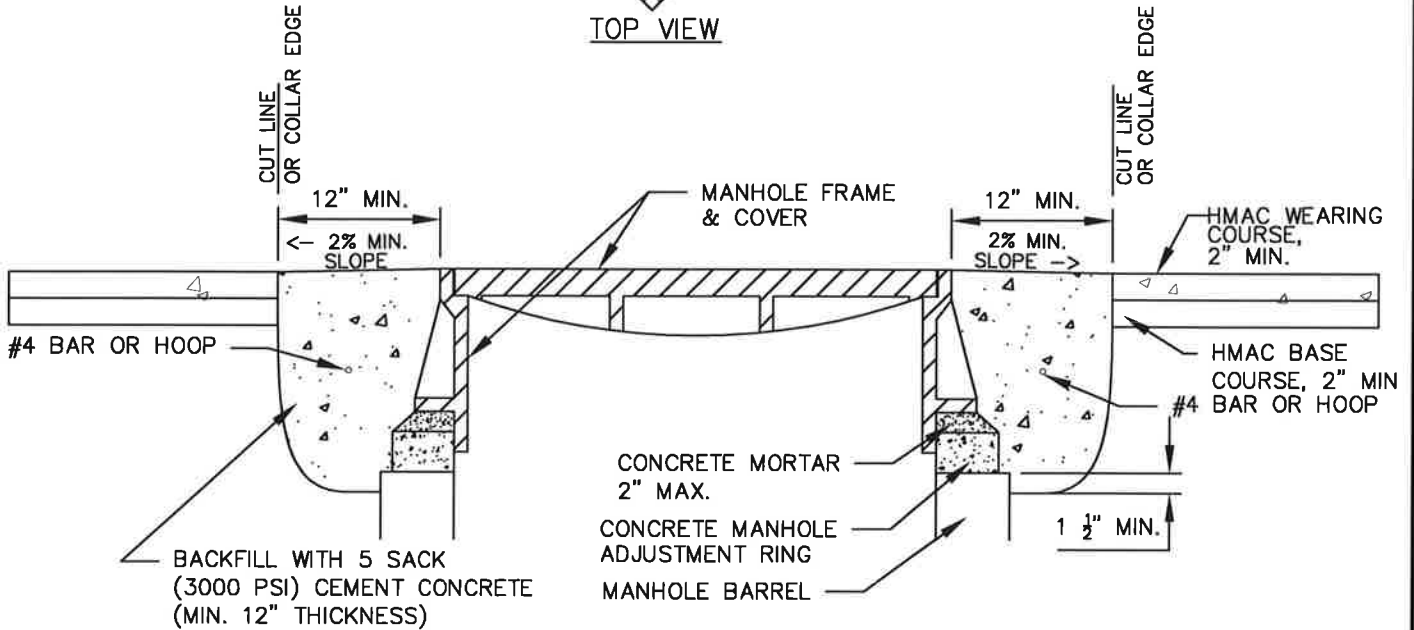

NOTES:

1. COVER MANHOLE WITH STEEL PLATE AND CONSTRUCT BASE AND FINISH ASPHALT COURSE.
2. CUT DIAMOND (WITH CORNERS POINTED TOWARD TRAFFIC) 12" MINIMUM FROM MANHOLE FRAME.
3. RAISE MANHOLE FRAME AND COVER TO FINISH GRADE BY INSTALLING CONCRETE ADJUSTMENT RINGS, STEEL SHIMS, AND LEVELING MORTAR. (NOTE: IF THE TOTAL OF THE CONCRETE RING ADJUSTMENTS NEEDED IS GREATER THAN 12", AN ADDITIONAL 12" MANHOLE BARREL SHALL BE INSTALLED).
4. INSTALL #4 REBAR.
5. BACKFILL WITH 5 SACK (3000 PSI) CONCRETE CEMENT SLOPED AT MIN. 2% (MAX. 4%) TO FINISH GRADE. FINISH CONCRETE IN A GOOD WORKMAN LIKE FASHION WITH BROOMED FINISH AND MINIMAL SPILLAGE ONTO SURROUNDING ASPHALT. TAPE AND TARP ASPHALT IF NEEDED. CLEAN UP ANY SPILLAGE ON ASPHALT AND VALVE CAN LID.
6. PROTECT FROM TRAFFIC LOADING FOR A MIN. OF 7 DAYS.



ENGINEERING
DEPARTMENT
500 S.W. DORION
AVENUE PENDLETON,
OREGON 97801
VOICE: (541) 966-0203
FAX: (541) 966-0251

APPROVED BY

FEBRUARY 2019
APPROVAL DATE

REVISED DATE

MANHOLE ADJUSTMENT

NO SCALE

DWG NO.

307C

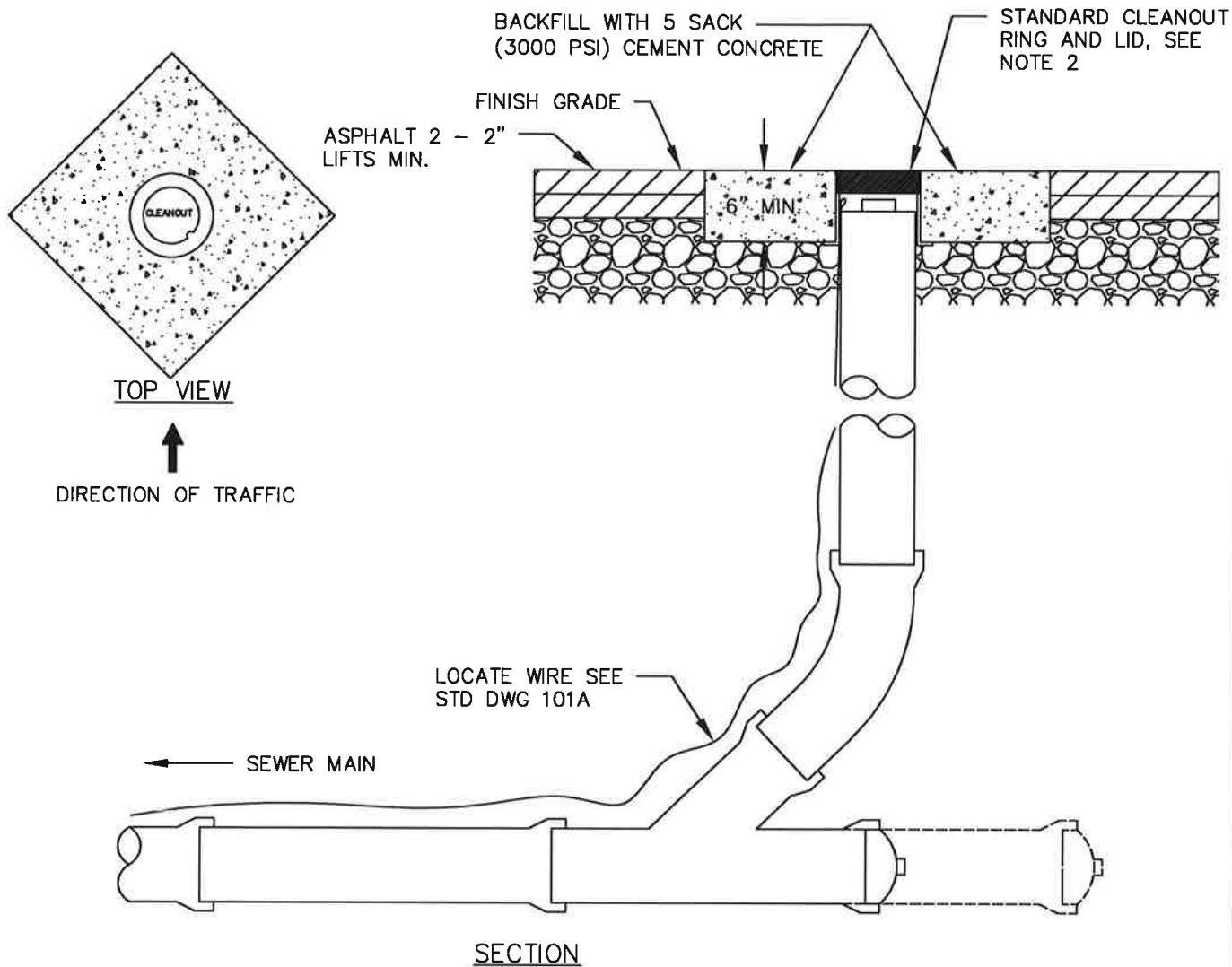

NOTES:

1. SET SEWER CLEAN OUT BOX BELOW GRADE AND CONSTRUCT BASE AND FINISH ASPHALT COURSE.
2. CUT DIAMOND (WITH CORNERS POINTED TOWARD TRAFFIC) 12" MINIMUM FROM CLEAN OUT FRAME.
3. RAISE AND ADJUST CLEAN OUT FRAME AND COVER TO FINISH GRADE. COVER CLEAN OUT LID WITH PLASTIC TO PREVENT CONCRETE FROM STICKING TO LID.
4. BACKFILL WITH 5 SACK (3000 PSI) CONCRETE CEMENT SLOPED AT MIN. 2% (MAX. 4%) TO FINISH GRADE. FINISH CONCRETE IN A GOOD WORKMAN LIKE FASHION WITH BROOMED FINISH AND MINIMAL SPILLAGE ONTO SURROUNDING ASPHALT. TAPE AND TARP ASPHALT IF NEEDED. CLEAN UP ANY SPILLAGE ON ASPHALT AND VALVE CAN LID.
5. PROTECT FROM TRAFFIC LOADING FOR A MIN. OF 7 DAYS.



ENGINEERING
DEPARTMENT
500 S.W. DORION
AVENUE PENDLETON,
OREGON 97801
VOICE: (541) 966-0203
FAX: (541) 966-0251

APPROVED BY

FEBRUARY 2019
APPROVAL DATE

REVISED DATE

**STANDARD
CLEANOUT
ADJUSTMENT**

NO SCALE

DWG NO.

309A

SEE DWG 320B FOR HOOD DETAIL

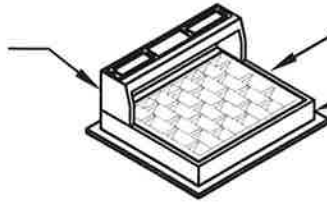

SEE DWG 320C & 320D FOR GRATE DETAILS

SEE DWG 320A FOR FRAME DETAIL

FRAME, VANED GRATE, AND HOOD

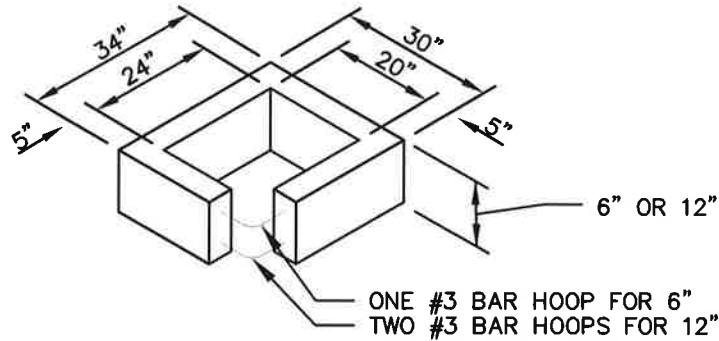

RECTANGULAR ADJUSTMENT SECTION

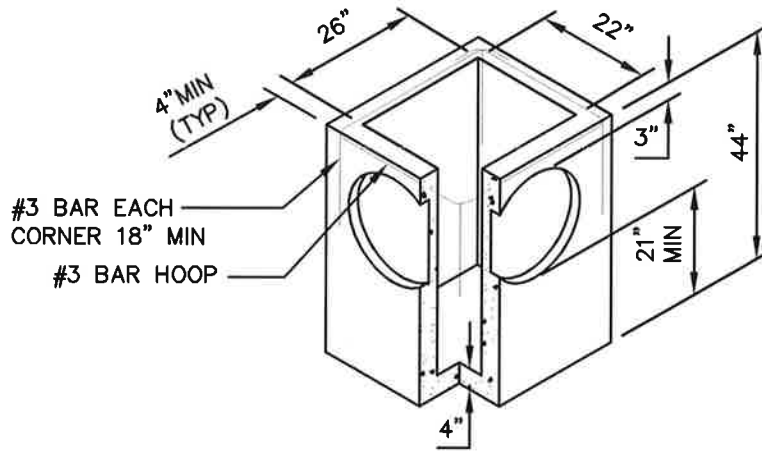

PRECAST BASE SECTION

NOTES:

- 1. REESE CONCRETE PRODUCTS CATCH BASIN TYPE 1 OR EQUAL.



ENGINEERING DEPARTMENT
500 S.W. DORION AVENUE
PENDLETON, OREGON 97801
VOICE: (541) 966-0203
FAX: (541) 966-0251

APPROVED BY

FEBRUARY 2019
APPROVAL DATE

REVISED DATE

**TYPE 1 30"X34"
RECTANGULAR
CURB INLET
CATCH BASIN**

NO SCALE

DWG NO.

320

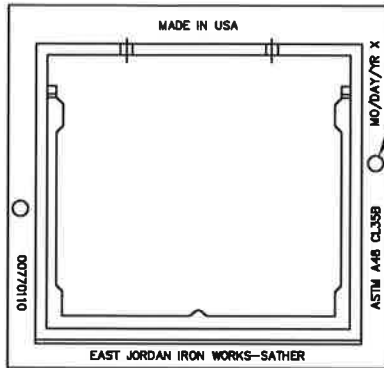

PLAN VIEW

(2) 1" [25mm] DIA
HANDLING HOLES

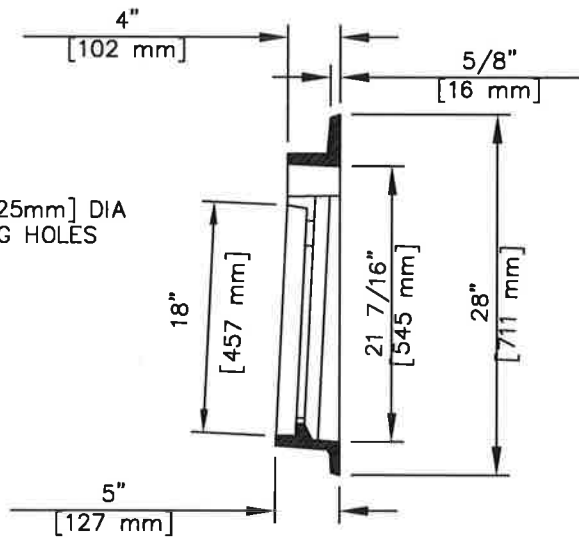

SECTION VIEW

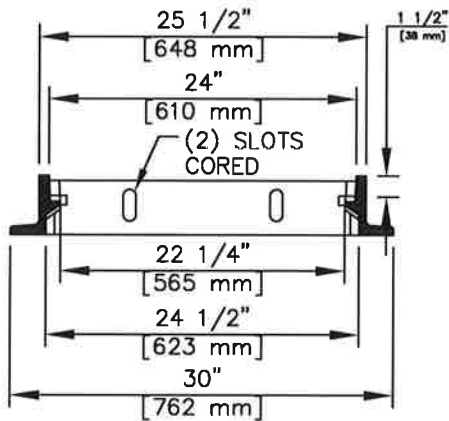

SECTION VIEW

NOTES:

1. CATCH BASIN FRAME SHALL BE EJIW 7701 Z FRAME UNBOLTED OR APPROVED EQUAL.
2. JOINTS SHALL BE WATER TIGHT AND COVER MATERIAL SPECIFICATION GRAY IRON (ASTM A48 CL35B).



ENGINEERING
DEPARTMENT
500 S.W. DORION
AVENUE PENDLETON,
OREGON 97801
VOICE: (541) 966-0203
FAX: (541) 966-0251

APPROVED BY

[Signature]

FEBRUARY 2019
APPROVAL DATE

REVISED DATE

CURB INLET CATCH
BASIN FRAME

NO SCALE

DWG NO.

320A

FISH LOGO TAG (RECESSED FLUSH) 1/2" SHARP FACE GOTHIC.

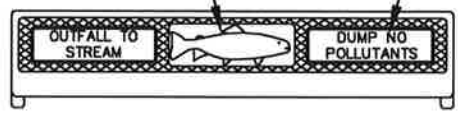

PLAN VIEW

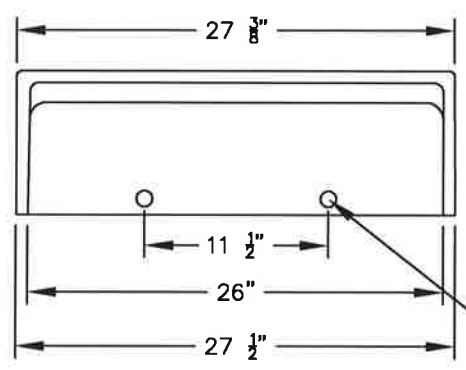

SECTION VIEW

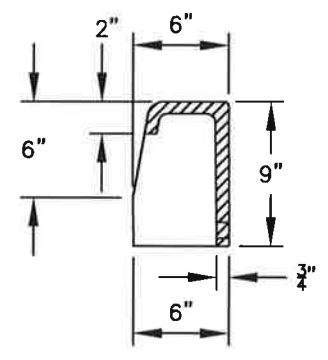

SECTION VIEW

- NOTES:**
1. CATCH BASIN HOOD SHALL BE EJIW 7701T1 HOOD OR APPROVED EQUAL.
 2. HOOD SHALL BE GRAY IRON ASTM A48 CL35B.



ENGINEERING DEPARTMENT
 500 S.W. DORION AVENUE PENDLETON, OREGON 97801
 VOICE: (541) 966-0203
 FAX: (541) 966-0251

APPROVED BY

 FEBRUARY 2019
 APPROVAL DATE
 REVISED DATE

CURB INLET CATCH BASIN HOOD

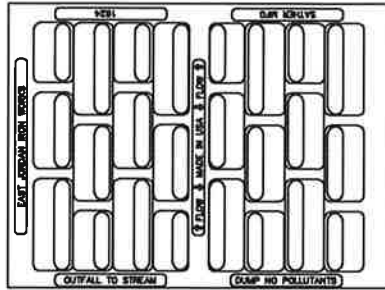
NO SCALE
 DWG NO.
320B

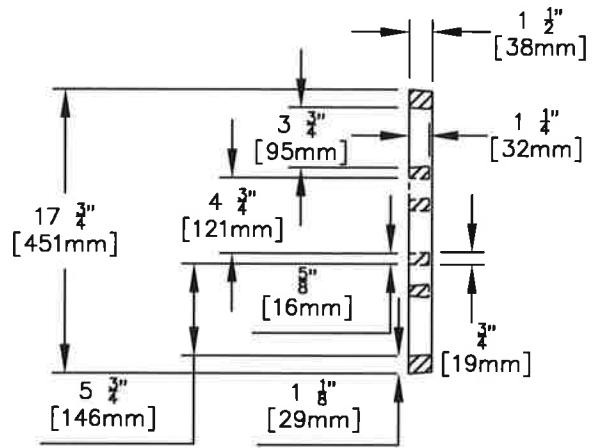

PLAN VIEW



SECTION VIEW

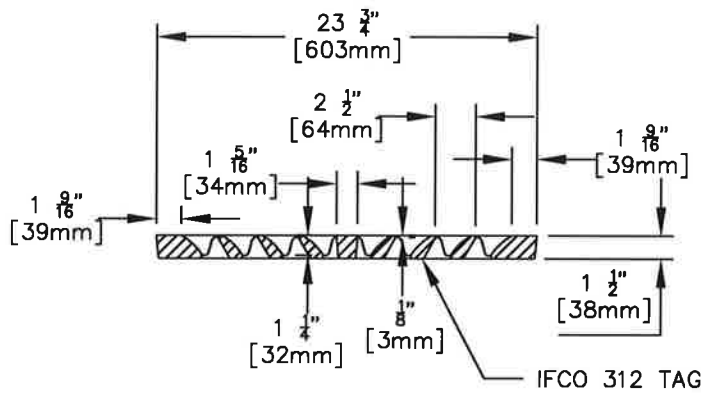

SECTION VIEW

NOTES:

1. CATCH BASIN GRATE SHALL BE EJIW 7700M3 DI BIDIRECTIONAL VANE GRATE OR APPROVED EQUAL.
2. GRATE SHALL BE DUCTILE IRON ASTM A536.



ENGINEERING DEPARTMENT
500 S.W. DORION AVENUE
PENDLETON, OREGON 97801
VOICE: (541) 966-0203
FAX: (541) 966-0251

APPROVED BY

FEBRUARY 2019
APPROVAL DATE

REVISED DATE

CURB INLET CATCH BASIN BIDIRECTIONAL GRATE

NO SCALE

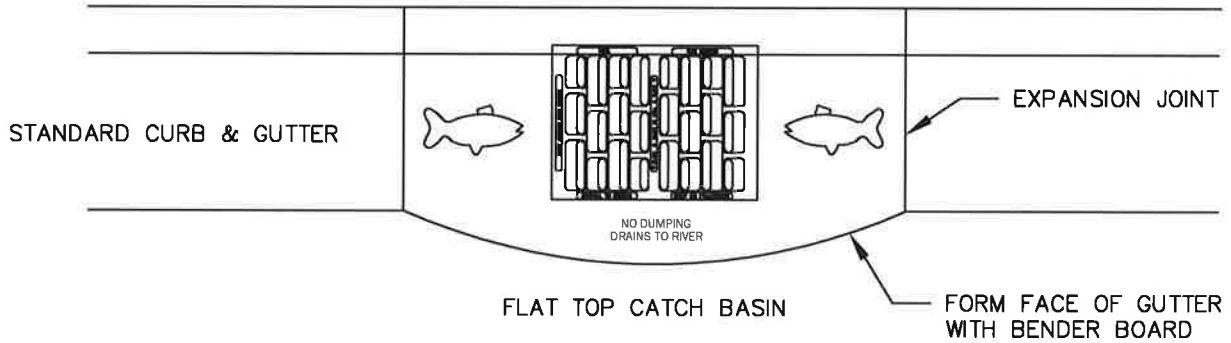
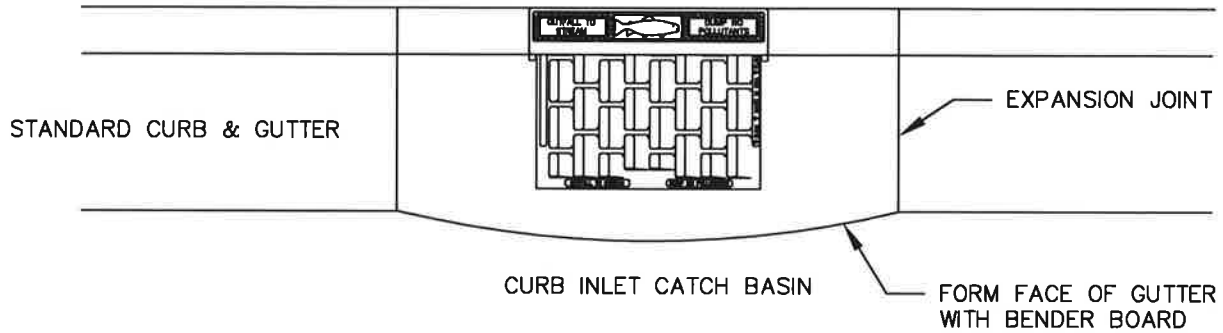

DWG NO.

320C



NOTES:

1. CONCRETE TO BE 3000 PSI AT 28 DAYS, 6 SACK MIX.
2. CATCH BASIN, FRAME, AND GRATE TO BE CITY STANDARD OR APPROVED EQUAL. SEE STD DWG 320 & 321.
3. DRAIN PIPE TO BE 12" MIN AND 24" MAX UP FROM BOTTOM OF CATCH BASIN.
4. CONCRETE STAMPING TO BE DONE AS SHOWN, AS APPROVED BY CITY.
5. FORM FACE OF GUTTER AT THE FRONT OF CATCH BASIN GRATE WITH BENDER BOARD.

 <p>ENGINEERING DEPARTMENT 500 S.W. DORION AVENUE PENDLETON, OREGON 97801 VOICE: (541) 966-0203 FAX: (541) 966-0251</p>	<p>APPROVED BY</p> 	<p>CATCH BASIN CONCRETE STAMPING DETAIL</p>	NO SCALE
	<p>FEBRUARY 2019 APPROVAL DATE</p> <p>REVISED DATE</p>		<p>DWG NO. 322</p>

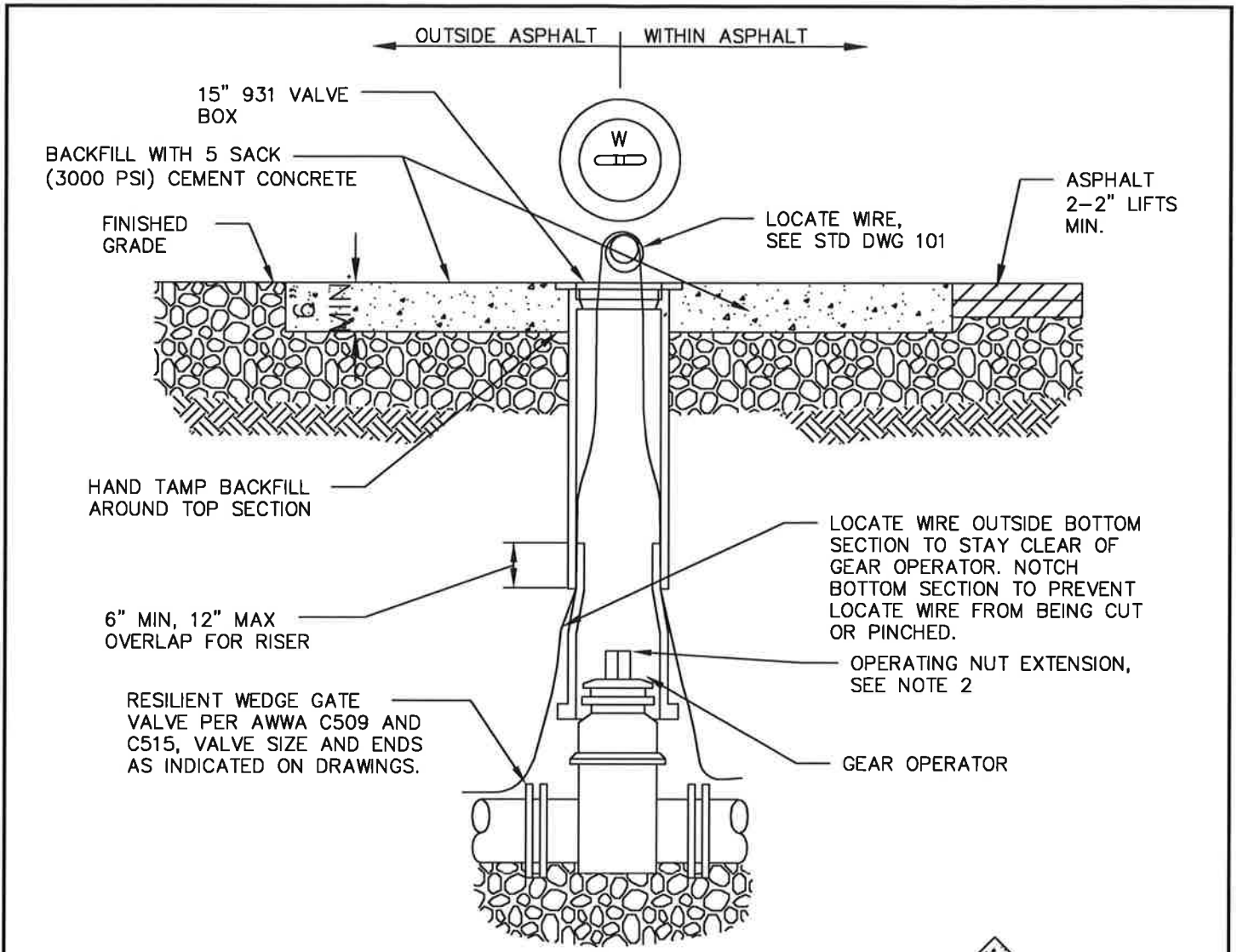



BURIED VALVE BOX

NOTES:

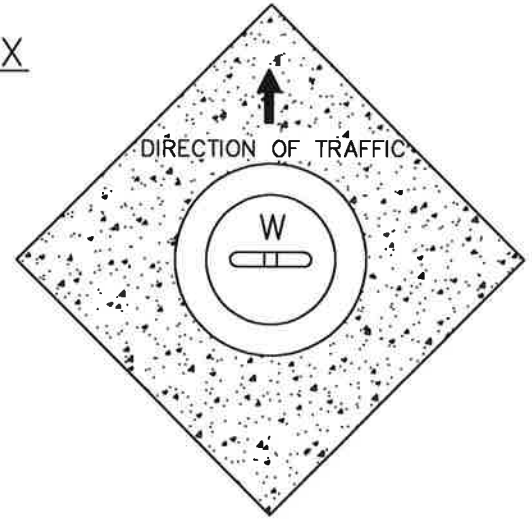
1. SET VALVE BOX BELOW GRADE AND CONSTRUCT BASE AND FINISH ASPHALT COURSE.
2. CUT DIAMOND (WITH CORNERS POINTED TOWARD TRAFFIC) 12" MINIMUM FROM VALVE BOX FRAME.
3. RAISE AND ADJUST VALVE BOX TO FINISH GRADE AND COVER VALVE CAN LID WITH PLASTIC TO PREVENT CONCRETE FROM STICKING TO VALVE CAN LID.
4. VALVE BOX NOT TO REST ON OPERATING ASSEMBLY.
5. OPERATING NUT EXTENSION REQUIRED WHEN VALVE NUT IS DEEPER THAN 4' FROM FINISHED GRADE. SEE STD DWG 403.
6. CENTER VALVE BOX ON AXIS OF OPERATING NUT.
7. ORIENT GEAR OPERATOR TO CENTERLINE SIDE IN ROADWAYS.
8. BACKFILL WITH 5 SACK (3000 PSI) CONCRETE CEMENT SLOPED AT MIN. 2% (MAX. 4%) TO FINISH GRADE. FINISH CONCRETE IN A GOOD WORKMAN LIKE FASHION WITH BROOMED FINISH AND MINIMAL SPILLAGE ONTO SURROUND ASPHALT. TAPE AND TARP ASPHALT IF NEEDED. CLEAN UP ANY SPILLAGE ON ASPHALT AND VALVE CAN LID.
9. PROTECT FROM TRAFFIC LOADING FOR A MIN. OF 7 DAYS.







CONCRETE PAD

 <p>ENGINEERING DEPARTMENT 500 S.W. DORION AVENUE PENDLETON, OREGON 97801 VOICE: (541) 966-0203 FAX: (541) 966-0251</p>	<p>APPROVED BY</p> 	<p>BURIED VALVE AND BOX ADJUSTMENT</p>	<p>NO SCALE</p>
	<p>FEBRUARY 2019 APPROVAL DATE</p> <p>REVISD DATE</p>		<p>DWG NO. 402</p>



General Notes

-  OVERLAY
-  END GRIND
0"-2" IN 20 FT
-  EDGE GRIND
0"-2" IN 8 FT
-  RECONSTRUCTION

BAR IS ONE INCH ON ORIGINAL DRAWING.
IF NOT ONE INCH ON THIS SHEET, ADJUST SCALE ACCORDINGLY.



RENEWAL: 06/30/2022
SIGNED: MAR 10 2022

No.	Revision/Issue	Date

Firm Name and Address
CITY OF PENDLETON
ENGINEERING DEPT
500 SW DORION AVE.
PENDLETON, OR 97801
(541) 966-0203

Project Name and Address
2022 OVERLAY PROJECT
SE COURT PLACE

Project 2022 OVERLAY	Sheet 2
Date JANUARY 2022	
Scale 1" = 80'	

Reconstruction Section – SE COURT PLACE

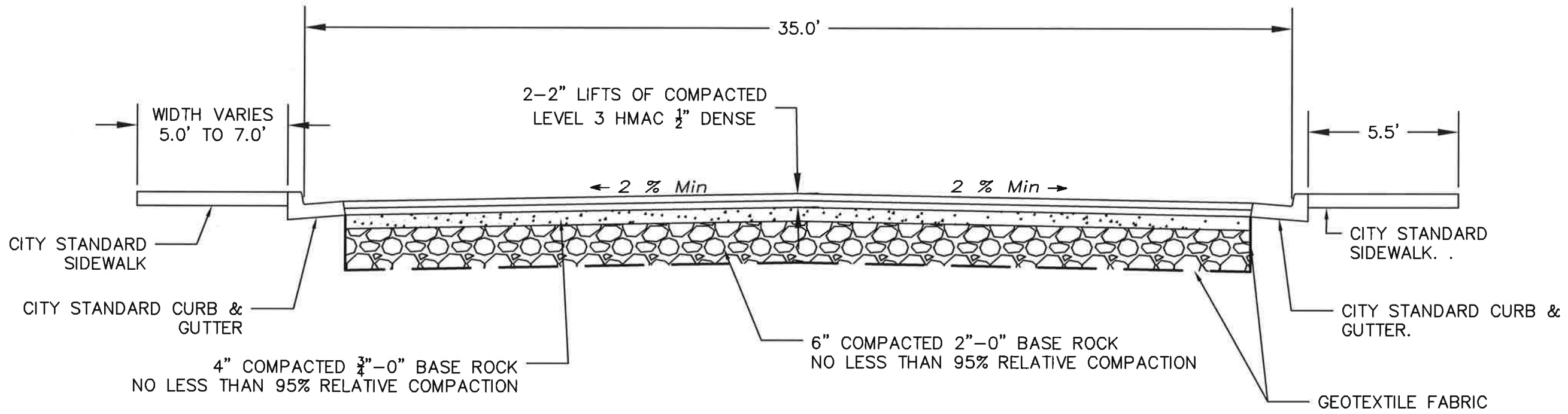

TYPICAL CROSS SECTION (CURB AND GUTTER)

General Notes

BAR IS ONE INCH ON ORIGINAL DRAWING.
 IF NOT ONE INCH ON THIS SHEET, ADJUST SCALE ACCORDINGLY.



RENEWAL: 06/30/2022
 SIGNED: MAR 10 2022

No.	Revision/Issue	Date

Firm Name and Address
 CITY OF PENDLETON
 ENGINEERING DEPT
 500 SW DORION AVE.
 PENDLETON, OR 97801
 (541) 966-0203

Project Name and Address
 2022 OVERLAY PROJECT

Project 2022 OVERLAY	Sheet 3
Date FEBRUARY 2022	
Scale	

ROAD CONSTRUCTION SECTION – SW 28TH DRIVE

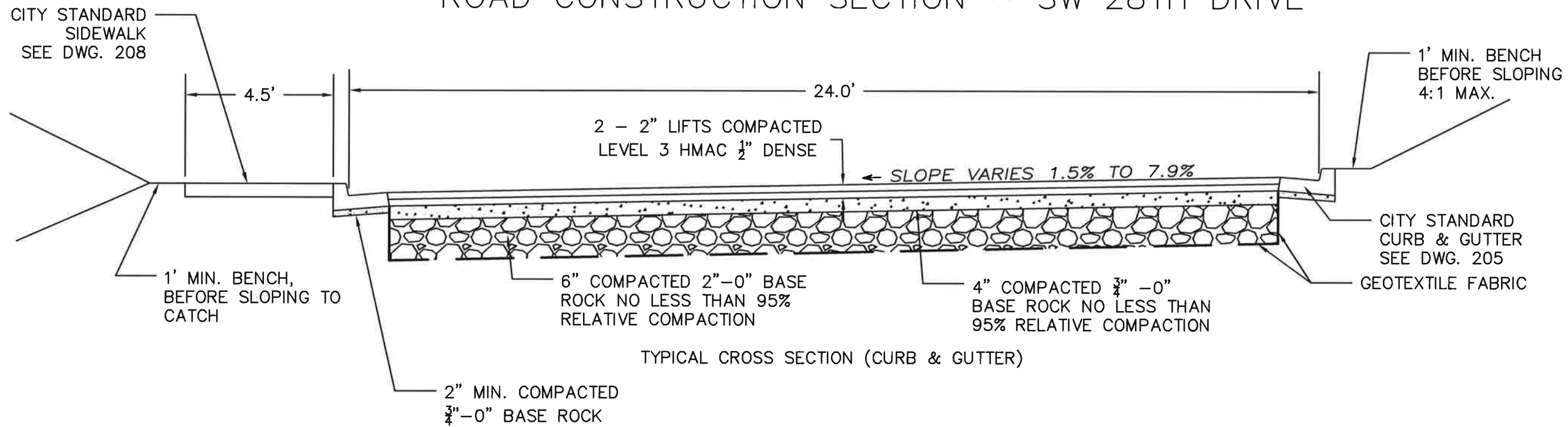

TYPICAL CROSS SECTION (CURB & GUTTER)

General Notes

BAR IS ONE INCH ON ORIGINAL DRAWING.
 0 IF NOT ONE INCH ON THIS SHEET, ADJUST SCALE ACCORDINGLY.



RENEWAL: 06/30/2022
 SIGNED: MAR 16 2022

No.	Revision/Issue	Date

Firm Name and Address
 CITY OF PENDLETON
 ENGINEERING DEPT
 500 SW DORION AVE.
 PENDLETON, OR 97801
 (541) 966-0203

Project Name and Address
 2022 OVERLAY PROJECT
 SW 28TH DRIVE
 CROSS SECTION

Project 2022 OVERLAY	Sheet 5
Date FEBRUARY 2022	
Scale	

STATION EQUATION

NORTH TBC STA 0+00 = \varnothing STA 0+00 LT 12.5'

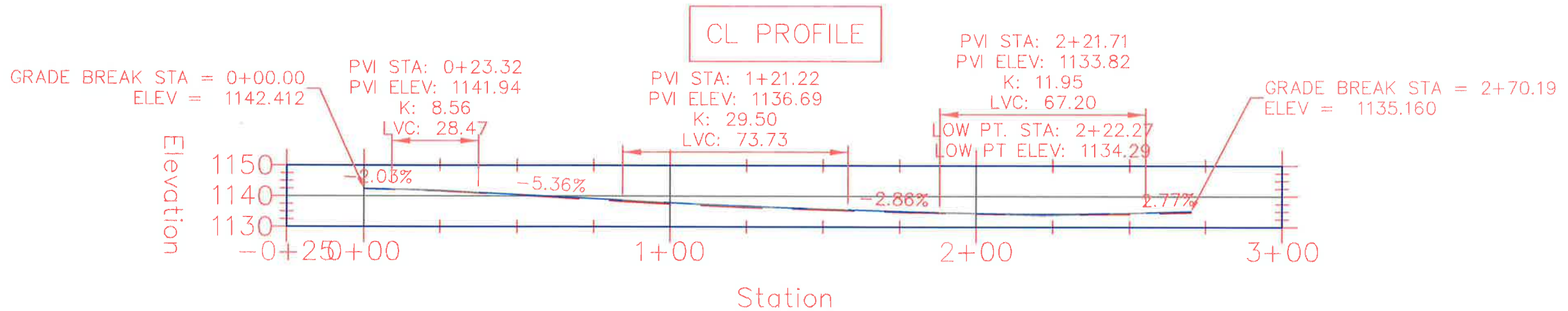
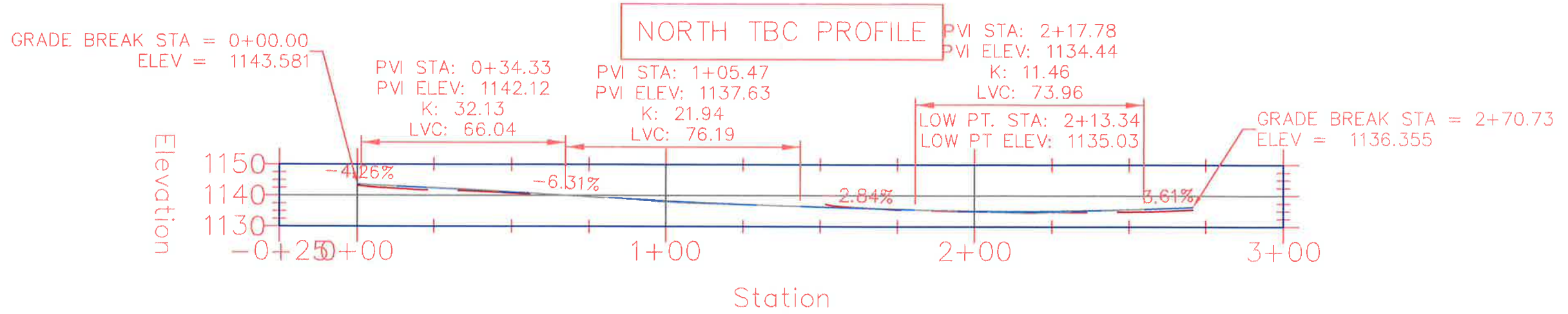

STATION EQUATION

SOUTH TBC STA 0+03.50 = \varnothing STA 0+00 RT 12.5'

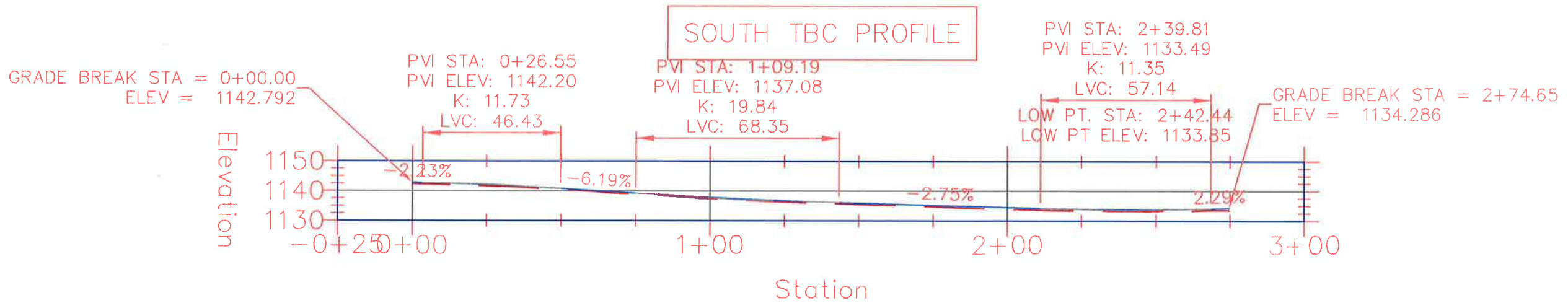

General Notes

BAR IS ONE INCH ON ORIGINAL DRAWING.
IF NOT ONE INCH ON THIS SHEET, ADJUST SCALE ACCORDINGLY.



RENEWAL: 06/30/2022
SIGNED: MAR 10 2022

No.	Revision/Issue	Date

Firm Name and Address

CITY OF PENDLETON
ENGINEERING DEPT
500 SW DORION AVE.
PENDLETON, OR 97801
(541) 966-0203

Project Name and Address

2022 OVERLAY PROJECT
CHANGE ORDER

SW 28TH DRIVE

Project

2022 OVERLAY
Date: FEBRUARY 2022
Scale: 1" = 40'

Sheet

6

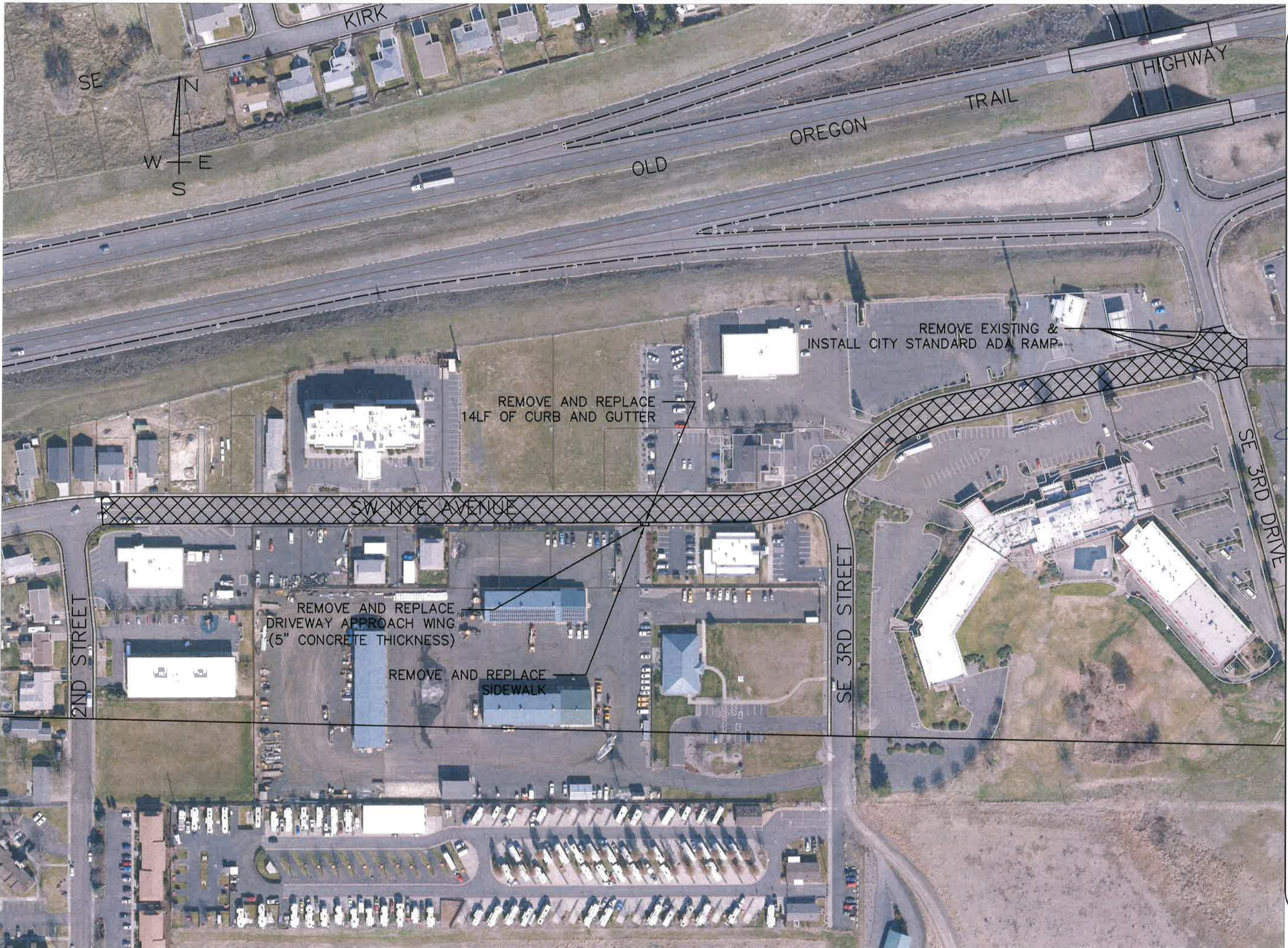

General Notes

 RECONSTRUCTION

BAR IS ONE INCH ON ORIGINAL DRAWING.
 IF NOT ONE INCH ON THIS SHEET, ADJUST SCALE ACCORDINGLY.



RENEWAL: 06/30/2022
 SIGNED: MAR 10 2022

No.	Revision/Issue	Date

Firm Name and Address
 CITY OF PENDLETON
 ENGINEERING DEPT
 500 SW DORION AVE.
 PENDLETON, OR 97801
 (541) 966-0203

Project Name and Address
 2022 OVERLAY PROJECT
 SW NYE AVENUE

Project 2022 OVERLAY	Sheet 7
Date JANUARY 2022	
Scale 1" = 150'	

Reconstruction Section – SW NYE AVENUE

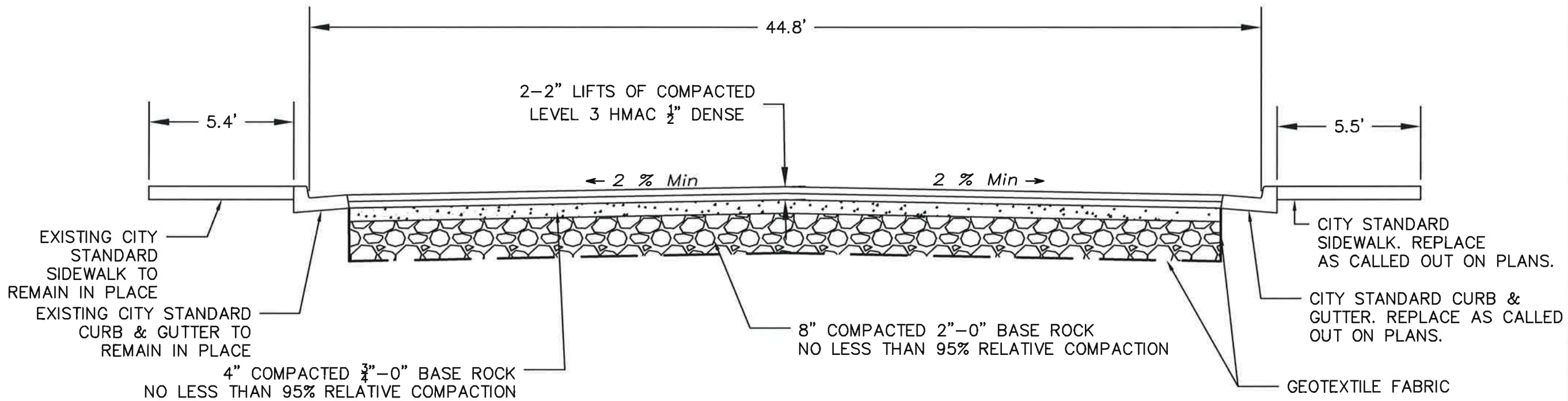

TYPICAL CROSS SECTION (CURB AND GUTTER)

General Notes

BAR IS ONE INCH ON ORIGINAL DRAWING.
 0 IF NOT ONE INCH ON THIS SHEET, ADJUST SCALE ACCORDINGLY.



RENEWAL: 06/30/2022
 SIGNED: MAR 16 2022

No.	Revision/Issue	Date

Firm Name and Address

CITY OF PENDLETON
 ENGINEERING DEPT
 500 SW DORION AVE.
 PENDLETON, OR 97801
 (541) 966-0203

Project Name and Address

2022 OVERLAY PROJECT
 SW NYE AVENUE –
 SW 2ND STREET TO SE 3RD DRIVE

Project 2022 OVERLAY	Sheet 8
Date JANUARY 2022	
Scale	

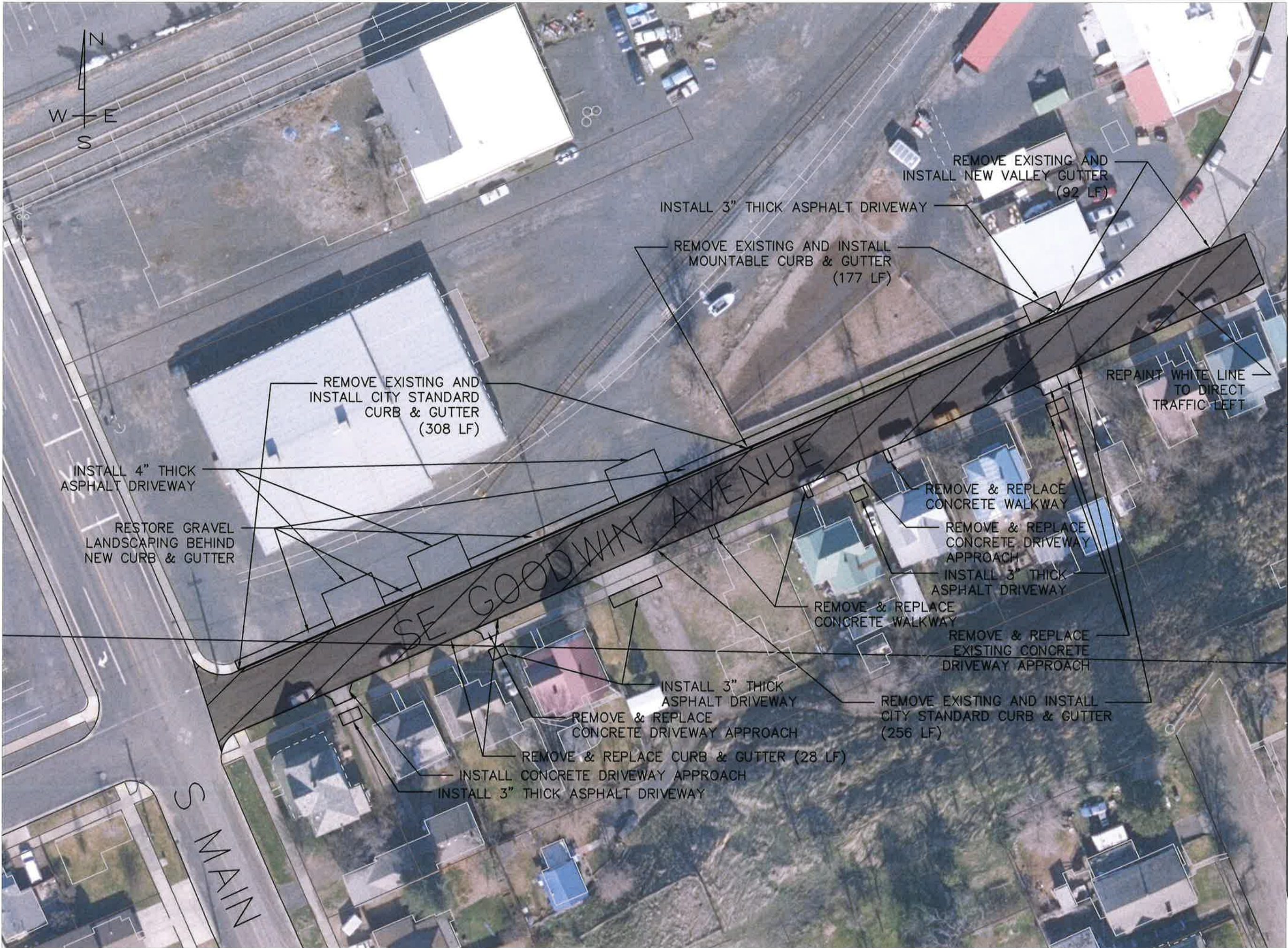

General Notes

- OVERLAY
- FULL STREET GRIND
0"-2"

BAR IS ONE INCH ON ORIGINAL DRAWING.
0
IF NOT ONE INCH ON THIS SHEET, ADJUST SCALE ACCORDINGLY.



RENEWAL: 06/30/2022
SIGNED: MAR 16 2022

No.	Revision/Issue	Date



Firm Name and Address
CITY OF PENDLETON
ENGINEERING DEPT
500 SW DORION AVE.
PENDLETON, OR 97801
(541) 966-0203

Project Name and Address
2022 OVERLAY PROJECT
SE GOODWIN AVENUE

Project 2022 OVERLAY	Sheet 9
Date JANUARY 2022	
Scale 1" = 50'	



General Notes

-  OVERLAY
-  FULL STREET GRIND 0"-4", TRANSITION TO 0"-2" AT ENDS. IF POSSIBLE 2" REVEAL ALONG GUTTER FACE.

BAR IS ONE INCH ON ORIGINAL DRAWING.

IF NOT ONE INCH ON THIS SHEET, ADJUST SCALE ACCORDINGLY.



RENEWAL: 06/30/2022
SIGNED: MAR 16 2022

No.	Revision/Issue	Date

Firm Name and Address
CITY OF PENDLETON
ENGINEERING DEPT
500 SW DORION AVE.
PENDLETON, OR 97801
(541) 966-0203

Project Name and Address
2022 OVERLAY PROJECT
NW ELLIS AVENUE

Project 2022 OVERLAY	Sheet 10
Date JANUARY 2022	
Scale 1" = 70'	



General Notes

-  OVERLAY
-  END GRIND
0"-2" IN 15 FT
-  EDGE GRIND
0"-2" IN 8 FT

BAR IS ONE INCH ON ORIGINAL DRAWING.
 0 IF NOT ONE INCH ON THIS SHEET, ADJUST SCALE ACCORDINGLY.



RENEWAL: 06/30/2022
 SIGNED: MAR 16 2022

No.	Revision/Issue	Date

Firm Name and Address
 CITY OF PENDLETON
 ENGINEERING DEPT
 500 SW DORION AVE.
 PENDLETON, OR 97801
 (541) 966-0203

Project Name and Address
 2022 OVERLAY PROJECT
 NW 14TH STREET

Project 2022 OVERLAY	Sheet 11
Date JANUARY 2022	
Scale 1" = 40'	